

where the world turns for couplings

Lovejoy[®]

Variable Speed Drives

In This Section:

- Econoline Series
- Aluminoline Series
- WB Series
- Hi-Ratio Series
- Hexadrive Series
- Adjusta-Sheave Series
- Adjustable Motor Bases
- Companion Sheaves
- Belts

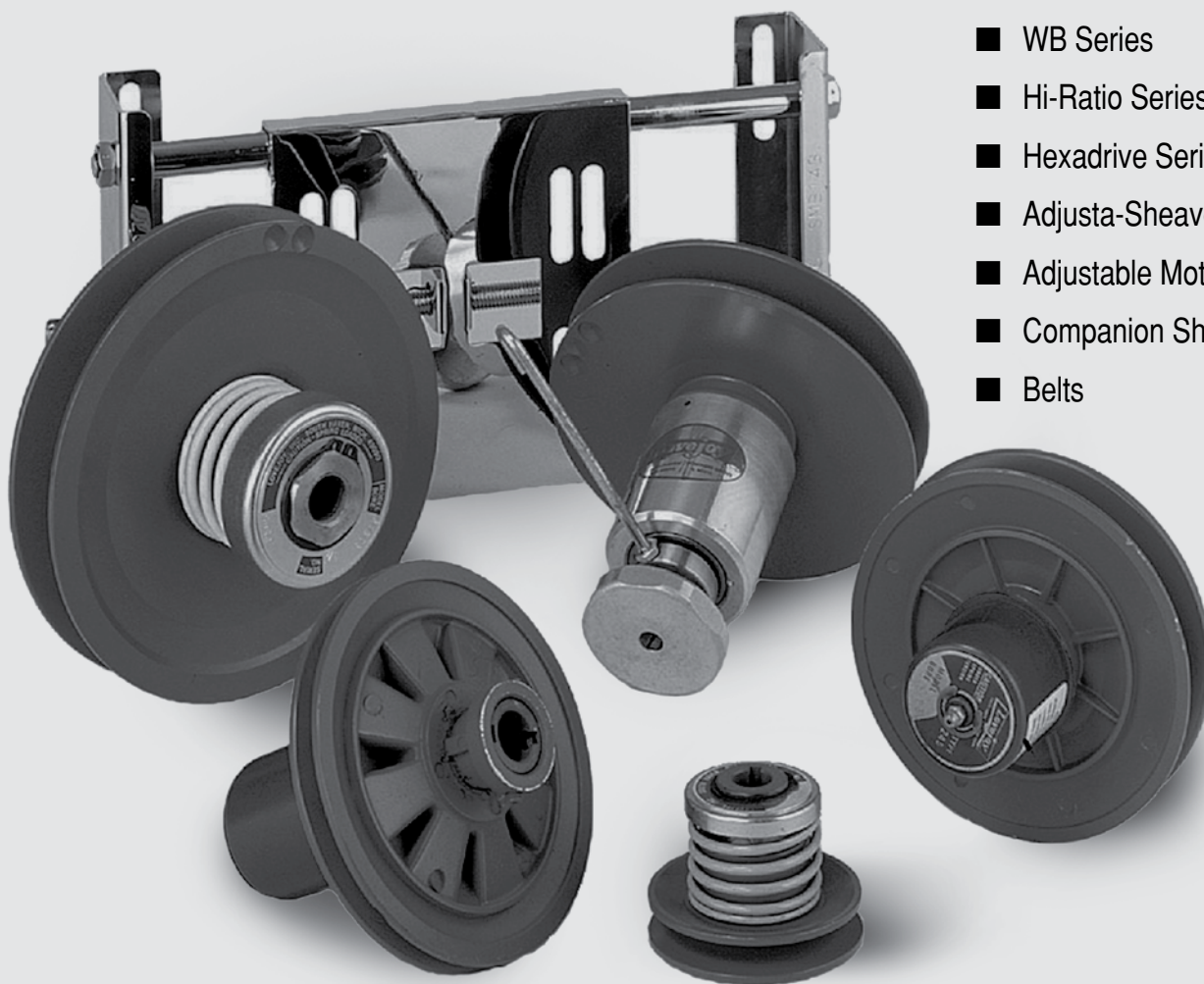

VSD

where the world turns for couplings

Lovejoy[®]

Variable Speed Drives

Safety Warning

When using Lovejoy products, you must follow these instructions and take the following precautions. Failure to do so may cause the power transmission product to break and parts to be thrown with sufficient force to cause severe injury or death.

Refer to this Lovejoy Catalog for proper selection, sizing, horsepower, torque range, and speed range of power transmission products, including elastomeric elements for couplings. Follow the installation instructions included with the product, and in the individual product catalogs for proper installation of power transmission products. Do not exceed catalog ratings.

During start up and operation of power transmission product, avoid sudden shock loads. Coupling assembly should operate quietly and smoothly. If coupling assembly vibrates or makes beating sound, shut down immediately, and recheck alignment. Shortly after initial operation and periodically thereafter, where applicable, inspect coupling assembly for: alignment, wear of elastomeric element, bolt torques, and flexing elements for signs of fatigue. Do not operate coupling assembly if alignment is improper, or where applicable, if elastomeric element is damaged, or worn to less than 75% of its original thickness.

For variable speed drives, variable speed pulley rim speeds must never exceed 10,500 feet per minute. Companion pulley speeds beyond the ratings contained in this catalog are not recommended. For Fixed Center Drives, do not start until a torque arm bracket is installed. Failure to install torque arm bracket will cause torque arm to rotate rapidly and may cause severe injury from moving parts. Do not attempt to disassemble spring loaded pulley because parts may be thrown with sufficient force to cause injury or death.

Do not use any of these power transmission products for elevators, man lifts, or other devices that carry people. If the power transmission product fails, the lift device could fall resulting in severe injury or death.

For all power transmission products, you must install suitable guards in accordance with OSHA and American Society of Mechanical Engineers Standards. Do not start power transmission product before suitable guards are in place. Failure to properly guard these products may result in severe injury or death from personnel contacting moving parts or from parts being thrown from assembly in the event the power transmission product fails.

If you have any questions, contact the Lovejoy Engineering Department at 1-630-852-0500.

VSD

where the world turns for couplings



Variable Speed Drives

Table of Contents

	Running Page No.	Section Page No.		Running Page No.	Section Page No.
Overview.....	344	VSD-4	Hi-Ratio Series > Overview	379	VSD-39
Adjustable Center > Selection Process	348	VSD-8	Hi-Ratio Models M-14 and 1401 > Item Selection.....	380	VSD-40
Fixed Center > Selection Process	349	VSD-9	Hi-Ratio Models M-19, 1902 and 1903 > Item Selection.....	381	VSD-41
Adjustable Center Example > Selection Process	350	VSD-10	Hi-Ratio Models M-23, 2303 and 2305 > Item Selection.....	382	VSD-42
Fixed Center Example > Selection Process	351	VSD-11	Hexadrive Series > Overview	383	VSD-43
Quick Reference List > Selection Data.....	352	VSD-12	Hexadrive Models 11407 and 11401 > Item Selection	385	VSD-45
Econoline Series > Overview	354	VSD-14	Hexadrive Models 11901, 11902 and 11903 > Item Selection.....	386	VSD-46
Econoline Inch Bore / Keyway > Item Selection.....	355	VSD-15	Hexadrive Models 12905 and 12907 > Item Selection.....	387	VSD-47
Econoline Spring-Pulley > Dimensional Data.....	356	VSD-16	Hexadrive Models 13207, 13210, 13220 and 13230 > Item Selection	388	VSD-48
Econoline M Type > Item Selection	358	VSD-18	Hexadrive Models 14407, 14420 and 14430 > Item Selection.....	389	VSD-49
Econoline M and MLA Type > Item Selection	359	VSD-19	Hexadrive Models 121407 and 21401 > Item Selection.....	390	VSD-50
Econoline Fixed Center Bore / Keyway > Item Selection	360	VSD-20	Hexadrive Models 21901, 21902 and 21903 > Item Selection.....	391	VSD-51
Econoline Fixed Center Belts > Item Selection	361	VSD-21	Hexadrive Models 22905 and 22907 > Item Selection.....	392	VSD-52
Econoline Two Sided – Inch Bore / Keyway > Item Selection	362	VSD-22	Hexadrive Models 23207, 23210, 23220 and 23230 > Item Selection	393	VSD-53
Econoline Two Sided / Adjustable Center / Belts > Item Selection.....	363	VSD-23	Hexadrive Models 24407, 24410, 24420 and 24430 > Item Selection	394	VSD-54
Aluminoline > Overview	364	VSD-24	Hexadrive Models M-007 and 21407 > Item Selection.....	395	VSD-55
Aluminoline Models 145 and 145-HD > Item Selection	365	VSD-25	Hexadrive Models HM-3, Pulleys C and Z > Item Selection.....	396	VSD-56
Aluminoline Models 160 and 160-HD > Item Selection	366	VSD-26	Hexadrive Models HM-7, Pulleys C and Z > Item Selection.....	397	VSD-57
Aluminoline Models 170, 175 and 180 > Item Selection	367	VSD-27	Hexadrive Models HM-30, Pulleys C and Z > Item Selection.....	398	VSD-58
WB Series > Overview	368	VSD-28	Hexadrive HEC > Dimensional Data	399	VSD-59
WB Models 245, 260 and 260-HD > Item Selection.....	369	VSD-29	Hexadrive HLA > Dimensional Data.....	400	VSD-60
WB Models 301E and 301E-HD > Item Selection	370	VSD-30	Adjusta-Sheave Series > Dimensional Data	401	VSD-61
WB Models 3030E and 3030E-HD > Item Selection	371	VSD-31	Adjustable Motor Bases > Overview	402	VSD-62
WB Models 303E and 303E-HD > Item Selection	372	VSD-32	Motor Base SMB > Dimensional Data.....	403	VSD-63
WB Models 401E, 402E and 403E > Item Selection	373	VSD-33	Motor Base Sliding Dove Tail Type > Overview / Dimensional Data	404	VSD-64
WB Models 3050E and 3050E-HD > Item Selection	374	VSD-34	Companion Sheaves – Flat / Grooved > Overview / Dimensional Data	405	VSD-65
WB Models 3075B, 3100B and 3150B > Item Selection.....	375	VSD-35	Companion Sheaves Grooved > Dimensional Data	406	VSD-66
WB Models M-007, 245 and 260 > Item Selection.....	376	VSD-36	Belts > Item Selection.....	407	VSD-67
WB Models M-1, 301C and 301D > Item Selection.....	377	VSD-37	Pulley Service Factors / Equations > Engineering Data.....	408	VSD-68
Models M-3, 3030C and 3030D > Item Selection.....	378	VSD-38			

VSD

Why Vary Speed?

Variable speed drives are needed because many applications are not run at the same speed all of the time, due to the surrounding conditions. Revolutions Per Minute (RPM) of the driven shaft need to be increased or decreased when there are changes in load conditions, application requirements, or other circumstances.

Variable speed belt drives achieve the versatility needed to maximize application efficiency and productivity while remaining an inexpensive solution. In the most typical installation, a belt connects a variable speed pulley to a driven sheave. The pulley is mounted on a motor shaft and the motor is at constant speed. Thus, the speed at the driven shaft is a ratio of the pitch diameters of the pulley and sheave.

Note: ■ For this catalog, Lovejoy terminology will refer to any variable pitch pulley as a “pulley” and to any non-variable pulley as a sheave, driven sheave, or companion sheave.

The RPM at the driven shaft is found by the following simple equation:

$$N_b = N_d \times d/D$$

Where N_b is the RPM at the driven shaft
 N_d is the RPM of the driving shaft
 d is the pitch diameter of the driver
 D is the pitch diameter of the driven

Since N_d is always a fixed RPM, it can then be seen that by changing the pitch diameter of either d or D , the driven RPM will change.

Common Mounting Methods

1) Adjustable Center Drives

This type of belt drive consists of one pulley and one sheave. The pulley is spring-loaded and is usually mounted on the driver shaft. The driver is most often an electric motor which is mounted on an adjustable motor base that can be moved toward or away from the driven sheave. The springs in the pulley take up any slack in the belt when an adjustment is made.

When the base is adjusted, moving the pulley toward the sheave, the RPM at the sheave increases. Likewise, when the base is adjusted away from the sheave, the RPM at the sheave decreases. In the photo at right (Adjustable Center V-V Drive), the drive is at its maximum speed position. This is called a V-V drive because the driven sheave is grooved. The pulley is called two-side moveable because it has two springs (one against each flange) and two moveable flanges.

Notice that the belt in the pulley is at the maximum pitch diameter, or “d” as mentioned in the previous equation. As the base is adjusted away from the sheave, “d” will decrease and the driven speed, N_b , will decrease proportionately.

The photos at right (Adjustable Center V-Flat Drive Maximum Speed Position and Adjustable Center V-Flat Drive Min. Speed Position) show a V-Flat drive, so called because the driven sheave is flat, not grooved. The pulley is called a one-side moveable type because it has only one spring and one moveable flange.

Note that in the Adjustable Center V-Flat Maximum Speed Position figure, the drive is at the maximum speed position, with the variable speed pulley flanges closed together and the belt at the maximum pitch diameter. As the motor base is adjusted to increase the center distance between the motor and the driven shaft, the moveable flange on the variable speed pulley opens to allow the belt to run at a smaller pitch diameter (Adjustable Center V-Flat Drive Minimum Speed Position).



Adjustable Center V-V Drive

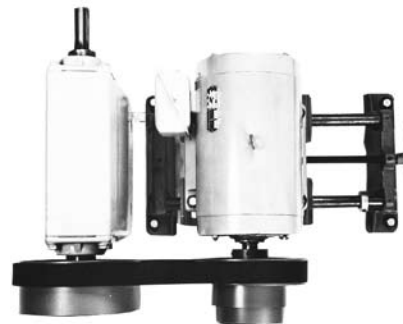

Adjustable Center V-Flat Drive
Maximum Speed Position



Adjustable Center V-Flat Drive
Minimum Speed Position

Continued



WARNING

You must refer to page VSD-2 (Page 342) for Important Safety Instructions and Precautions for the selection and use of these products. Failure to follow the instructions and precautions can result in severe injury or death.

Note that the axial position of the belt on the flat-faced companion sheave changes as the drive moves through the speed range. This illustrates the need for a flat-faced companion sheave when using a wide variable speed belt and a one-side moveable variable speed pulley.

The Adjustable Center Angle Mount Drive figure shows a more unusual mounting, with a one-side moveable pulley driving a grooved sheave. The motor base must be offset at an angle to keep the belt in line.

A typical Lovejoy adjustable center drive will have a speed ratio – that is, the range of speed at the driven sheave – from 1.6 to 1 up to 3.8 to 1. For example, with the right combination of pulley and sheave, you can attain a speed range at the driven sheave of 1,800 to 600 RPM, 3 to 1 speed ratio.

An alternate mounting method may be used when the spring-loaded pulley is mounted on the driven shaft, with the companion sheave mounted on the driver shaft. With this arrangement, the horsepower at the driven shaft is constant through most of the speed range, but the torque decreases in proportion to the pitch diameter of the belt in the spring-loaded pulley. Caution must be taken not to overspeed the driven variable speed pulley beyond 10,500 FPM (feet per minute) rim speed.

2) Fixed Center Drives

This method of mounting requires no change in center distance between the driver and driven units. Because the shaft center-to-center distance does not change, this is called a fixed center drive. The usual arrangement has one pulley, the driver, which is mechanically adjustable.

The adjustable pulley flanges are opened or closed mechanically, usually with a handwheel on the end of the pulley. The other pulley is spring-loaded and compensates for belt slack when the adjustable pulley is actuated.

When the adjustable driver pulley is fully opened, the belt is at its minimum pitch diameter. At the same time, the spring-loaded driven pulley is fully closed with the belt at its maximum pitch diameter. This results in the slowest possible driven speed. As the adjustable pulley flanges are closed together, the driver pulley pitch diameter increases while at the same time the spring-loaded pulley is forced by the drive belt to open. This results in a smaller pitch diameter at the driven member. The driven speed then increases until the adjustable pulley is fully closed and the spring-loaded pulley is fully open (the maximum speed position).

Speed change must always take place while the motor is running. The Fixed Center Drive figure shows a typical arrangement, with the adjustable pulley at minimum pitch diameter and the spring-loaded pulley at maximum pitch diameter. This is the minimum speed position.

Fixed center drives are used where space is limited and/or where a wider speed range is needed. They are sometimes called “compound drives” because the ratio of the two pulleys is compounded, resulting in a greater available driven speed range.

Speed ratios up to 11.5 to 1 are possible, but this is not necessarily in the form of a speed decrease. For example, with a 1,750 RPM motor and a Lovejoy HM-3/31901 drive package, the output speed at the driven pulley could be as high as 4,850 RPM.



Adjustable Center Angle Mount Drive



Fixed Center Drive

Horsepower vs. Torque

Adjustable center drives with the spring-loaded pulley as the driver are constant torque drives. That is, for each variable speed pulley and companion sheave combination, the torque at the sheave is constant. Horsepower decreases in proportion to RPM at the driven sheave.

Fixed center drives are constant torque from minimum speed to driver speed and constant horsepower from driver speed to maximum speed.

Notes: ■ All Lovejoy pulleys and sheaves are balanced for operation at 1,750 RPM. Balancing for higher speed operation is available—consult our Engineering Department.

■ Lovejoy variable speed pulleys are bored to fit standard NEMA motor shafts. Consult our Customer Service Department for availability of non-standard and metric bores.

Variable Speed Pulley Product Preview

Lovejoy offers the most complete line of non-enclosed variable speed belt drives from fractional through 30 horsepower. Each component is made with the quality and reliability that Lovejoy builds into all of its power transmission products.

Features

- Very economical and reliable method of speed change
- Allows the user to find the ideal speed without changing sheaves and belts. This is especially important on applications where final driven speed is critical and difficult to attain with two fixed-diameter sheaves. Speed range within the ratio is infinite, and speed change is accomplished quickly, while the drive is running
- Can be used as a highly efficient belt tensioner, with no adjustment necessary
- Offers a form of "soft start," eliminating belt slip and premature wear on belt drives with inherent high torque start-up requirements

Econoline Series

The Econoline Pulley series provides reliable variable speed service with a proven design at an economical cost. Consisting of a wide selection of models, the Econoline series is ideal for both adjustable and fixed center drives using classic "A" and "B" (or 4L and 5L) section drive belts. This series also offers: driven speed ratios from 1.6 to 1 up to 2.7 to 1 and horsepower ranges from fractional through 5 HP @ 1,750 RPM motor speed.

The flanges are constructed of durable cast iron. Typical applications of this maintenance-free pulley include: conveyors, mixers, small machine tools, mower traction drives, printing equipment, packaging machines, and belt tensioners.

Aluminoline Series

Aluminoline variable speed pulleys offer the best possible belt alignment with the least amount of overhung load. Used with "A" and "B" drive belts, these pulleys not only have anodized aluminum flanges which provide quiet operation with minimum vibration, but are rated for 1/3 through 1-1/2 HP motors. These two-side moveable pulleys offer greater speed ratios (up to 2.75 to 1).

Due to the corrosion-resistant properties of these pulleys, they are ideal for use on agricultural machinery, food packaging and bottling equipment, baseball pitching machines, and a variety of other products.



Econoline Series



Aluminoline Series

WB Series

Pulleys in the WB series use wide variable speed belts for the most efficient transmission of torque through the widest possible speed range. This two-side moveable pulley series offers the best possible belt alignment when used with a grooved companion sheave. WB pulleys provide maximum service when lubricated through a convenient grease fitting and offer sizes ranging from 6 to 13 inches in diameter, with the largest model capable of 15 HP. All models greater than 1 HP feature durable cast iron flanges (Models 245 and 260 are made with lightweight, corrosion-resistant anodized aluminum flanges).

These pulleys can be used on both adjustable and fixed center drives. Typical applications include: conveyors, printing presses, mixers, packaging and bottle-filling machines, machine tools, and agricultural equipment.



WB Series

Hi-Ratio Series

Hi-Ratio drives provide the unique combination of broader driven speed ranges and lowest possible minimum driven speed. Three drive packages are available, with horsepower ranges from 1/2 to 5, with a 1,750 RPM motor, and speed ratios up to 11.5 to 1. They are ideal for use on machine tools and mixing machinery.



Hi-Ratio Series

Hexadrive Series

Hexadrive pulleys are the most durable variable speed pulleys available. The hexagon-shaped center shaft efficiently transmits torque through the six hex flats for top performance and long life. The surface of the shaft is covered with a resilient elastomer, which means there is no metal-to-metal contact on any sliding surface and lubrication is not necessary.

These pulleys are available in adjustable or fixed center drives and come in two styles: one-side moveable for V-Flat drives, and two-side moveable for V-V drives. Flanges are made of cast iron to provide a long-wearing belt contact area. These pulleys provide size ranges from 6 inches up to 12.5 inches in diameter, and a maximum rating of 30 HP @ 1,750 RPM.

Some typical applications include: agricultural equipment, food packaging machines, air handling systems, textile spinning frames, mixers, pumps, machine tools, and foundry snag grinders.



Hexadrive Series

Adjusta-Sheave Series

The Lovejoy Adjusta-Sheave can be a cost-saving alternative to a spring-loaded pulley when speed change is infrequent. To change speeds, the drive must be shut down (unlike other variable speed pulleys). All models use wide variable speed belts.

The Adjusta-Sheave design eliminates the need for internal drive keys, thus providing more efficient transfer of power and longer life. The two cast iron flanges are moveable, allowing perfect belt alignment at all times. Four models are available with ranges from 5 through 30 HP and speed ratios up to 2.5 to 1. Typical applications include: textile spinning frames, heating and air conditioning equipment, pumps, etc.



Adjusta-Sheave Series

VSD

Factors to Consider

Torque and Horsepower:

Variable speed drives with constant torque loads can usually be selected by matching the variable speed pulley rating to that of the driver. Drive selection begins by matching the HP ratings, but final selection is based on torque, HP and RPM at the driven sheave. The application charts in this catalog specify driven speeds and torque ratings at the driven sheave for each pulley/sheave combination.

Driven Speed Range (Ratio)

As a general rule, an adjustable center drive can attain a maximum driven speed ratio of 3 to 1. Most fixed center drives can attain ratios as high as 8 to 1, but part of the driven speed range is faster than the motor speed. In all cases, pulleys that use variable speed belts will provide greater speed range than those using "A" or "B" belts.

Space

In some cases the amount of available space will determine the size of the pulley and whether to use an adjustable or fixed center drive.

Maintenance

Econoline and Hexadrive pulleys are virtually maintenance-free. They do not require lubrication or frequent speed change. Aluminoline and WB

pulleys require lubrication and occasional cycling through the speed range for best results.

Retrofit

When replacing a variable speed pulley made by another manufacturer, it is important to select a Lovejoy pulley that is the same style, uses the same size belt and is as close as possible to the same diameter. The Quick Reference List on VSD-12 provides this information at a glance. If you need help with a pulley interchange, call our Customer Service Department.

Belt Selection

Wide variable speed belts offer several advantages over stock "A" and "B" (or 4L and 5L) belts and should be considered for all variable speed pulley drives. Variable speed belts are designed to operate over small pitch diameters, offer a broader speed range and form themselves to the pulley faces at all speeds.

Shaft Sizes

Lovejoy variable speed pulleys are bored to fit standard NEMA motor shafts. The bore range for each model corresponds to its horsepower rating. Consult our Customer Service Department for availability of non-standard and metric bores. Companion sheaves are bored for bushings for ease of installation, optimum performance, and availability of product.

Steps An Selecting An Adjustable Center Belt Drive

There are two common selection processes; one is for designing an entire drive package, the other to select a replacement component part of an existing drive, such as the variable speed pulley. It is important to understand the complete drive selection process in order to do either. First, review the "factors to consider" and the selection examples on this page. Then follow these procedures:



Typical Adjustable Center Drive

requirement. If more than one sheave will provide the correct speed range, select the largest one possible. This will provide the greatest amount of torque. (Lovejoy only supplies companion sheaves for wide variable speed belts.) You will also need to check the correct style bushing, bored to the driven shaft size to fit the sheave (see page SF-17). With the Econoline and Aluminoline series, the selection chart merely indicates the pitch diameter of the sheave you need to use.

Step 4: Use the selection chart for the pulley/sheave combination you have chosen to find the distance between motor shaft and driven shaft (center distance) that is nearest your requirement. This will be the center distance at maximum speed position, or the point at which the motor shaft and driven shaft are closest together. Space must be provided in the machine to allow the center distance to be increased enough to attain the complete speed range. When you have found the center distance in the chart, read up or across to select the correct drive belt. Lovejoy only supplies variable speed belts. With the Econoline and Aluminoline pulley series, our selection charts will specify the pitch length of the correct V-belt to use.

Step 5: Select a suitable motor base from the catalog page for the pulley you have selected, or by reviewing the information on pages VSD-62 through VSD-64. You will need to know the NEMA motor frame size for this step.

For a complete adjustable center drive package, you will need a variable speed pulley, an adjustable motor base, a companion sheave with a bushing, and a drive belt. Be sure to specify the bore sizes for the variable speed pulley and the bushing (see page SF-17).

Designing a Complete Drive Package

- Step 1:** Match the variable speed pulley with the motor horsepower and speed, but consider the torque and HP required at the driven shaft at all speeds. If actual torque and HP requirements are not known, rely on the fact that variable speed pulley ratings are compatible with the torque of the driver. Apply a service factor if needed.
- Step 2:** Detailed drive selection data can be found on pages associated with the pulley that has been selected. Be sure the bore capacity of the pulley is suitable for your application.
- Step 3:** Refer to the Application chart that applies to the pulley you have chosen and select a companion sheave that suits the driven speed



Variable Speed Drives

Fixed Center Selection Process

Replacing a Drive Component

Please keep the above steps in mind, even though they won't all apply.

Replacing a Variable Speed Pulley

Step 1: Use the Quick Reference List on page VSD-12 and VSD-13 to narrow down your choices based on the information you have. For example, if you know the pulley diameter and belt size, check the appropriate columns in the list and pick out all models that match.

Step 2: Check the dimensional and performance details from the appropriate catalog page for the models you selected to find the best choice. In all replacement decisions, it is very important to consider the pulley style – 1, 2, or 3 (see page VSD-12) to get the best possible fit to the existing drive. Do NOT try to use a Lovejoy variable speed pulley with a belt that is not designed to drive. You will not attain the advertised speed range, and you may experience premature wear.

Replacing a Companion Sheave

Step 1: For a grooved sheave, determine the outside diameter of the sheave and the belt size. For a flat-faced sheave, measure the outside diameter and the face width.

Step 2: Select the correct sheave from catalog pages VSD-65 and VSD-66.

Step 3: Replace the bushing (see page SF-17).

Replacing an Adjustable Motor Base

Step 1: Determine the NEMA motor frame size or motor foot-mount dimensions.

Step 2: Select the correct base from the catalog pages VSD-62 through VSD-64. If it is NOT a Lovejoy base that is being replaced, be aware that the base mounting bolt locations may not match, and new holes may need to be drilled to mount the Lovejoy base to the machine.

Step 3: Check overall dimensions to be sure the base will fit the allotted space.

Selecting a Fixed Center Belt Drive

To select a fixed center package, it is necessary to know the following information:

- Horsepower and RPM of driver unit.
- Required speed range at the driven shaft.
- Torque requirement at the driven shaft.
- Shaft center-to-center distance.
- Driver AND driven shaft sizes.
- The relationship between driver and driven shafts (C vs. Z mount). Refer to the drawing below.

Lovejoy makes four types of fixed center drives: Econoline, WB, Hexadrive, and Hi-Ratio. The proper series to use depends on the horsepower rating, the required speed range, and the belt preference, as well as space and economic considerations. Once you have the information listed above and have selected the appropriate series, use the following procedure:

Step 1: Using the horsepower, driver speed, and required driven speed range information from above, select the appropriate series from Econoline, WB, Hi-Ratio, or Hexadrive.

Step 2: Select the correct manual driver pulley by choosing the model that is rated for your motor HP and speed. Be sure the pulley comes with a bore size that fits your motor shaft. Contact Lovejoy Customer Service for the availability of non-standard bores.

Step 3: Using the application chart for the pulley you have selected, choose a driven spring-loaded pulley that will handle the HP and torque requirement. Note that all Lovejoy fixed center drives are rated as constant horsepower from the base speed (motor speed) to the maximum driven speed. They are constant torque drives from base speed down to minimum driven speed. The ratings shown are those at the driven pulley.



Typical Fixed Center Drive

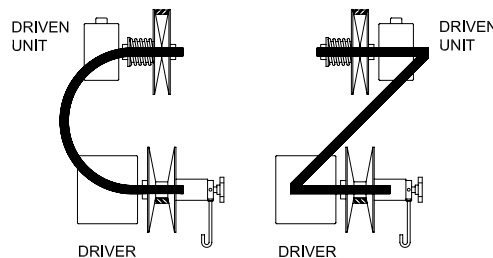

C and Z Mounting

Continued

VSD



Variable Speed Drives

Adjustable Center Example

Selection Process

IMPORTANT: Be sure to specify the correct driven pulley for the mounting arrangement. For example, you need to specify an “R” suffix (for reverse mount) with the Econoline Series spring-loaded pulley if it is a “C” mount. Also check to be sure the driven pulley is available in the bore size that will fit the driven shaft.

Step 4: Using the shaft center-to-center distance from “d”, select the correct drive belt from the Selection Chart. The center distance between the shafts must be held to the correct distance for the drive belt that is used in order to attain the published speed range. Drive belts are available only in certain lengths, so the center distance may need to be altered from the original design in order to suit the best available belt. If you have a center distance that is

not shown in the chart, refer to the formulas in the Variable Speed Engineering Data on page VSD-68, or call Lovejoy Engineering for assistance in calculating the correct center distance.

Step 5: Specify the Lovejoy Model 501 Torque Arm Bracket to prevent rotation of the manual pulley handwheel so that it can be adjusted while the motor is running. This item is NOT required for MLA or HLA driver pulleys.

Step 6: For remote control or linear actuation of the manual pulley, refer to the appropriate section in the Econoline (MLA), Hi-Ratio, or Hexadrive (HEC, HLA) section of this catalog.

Selection Examples: Adjustable Center Drives

WB Series Selection Example

A belt conveyor application requires a drive with a 2.8 to 1 speed ratio. The drive will consist of a variable speed belt drive, a speed reducer, and a chain drive from the reducer to the conveyor head pulley. The input speed range to the reducer must range from 370 to 1,050 RPM. The motor is 1 HP @ 1,150 RPM, with a NEMA 145T frame and 7/8 inch shaft. The torque into the reducer must be 50 in-lb. Center distance between the motor shaft and the reducer input shaft is about 15 inches.

Step 1: The WB series is chosen to fit into existing motor belt guards and motor mounts (see page VSD-30).

Step 2: For 1 HP @ 1,150 RPM, the Model 301E variable speed driver pulley with a 7/8 inch bore (to fit the motor shaft) is selected.

Step 3: From the Driven Sheave Selection chart for the Model 301E pulley, the 1922G8SK should be used because it offers a driven speed range of 360 to 1,075 RPM, which covers the requirement for this drive. Note that the torque rating for this drive 58 in-lb. This is a constant torque output throughout the driven speed range. An SK bushing is needed to attach the companion sheave to the driven shaft.

Step 4: From the Belt Selection chart, under the column headed by the 1922G8SK sheave, read down to find the center distance, then follow to the left to find the appropriate drive belt. The center

distance nearest to 15 inch in the chart is 15.4 inches. Notice that the motor travel for full speed range with the 301E pulley is 3.5 inches, so the maximum center distance will be about 19 inches.

Step 5: Select a suitable motor base based on the NEMA motor frame size. For a 145T frame, there are two choices: the Model 301 cast iron base, or the Model SMB-184 steel base.

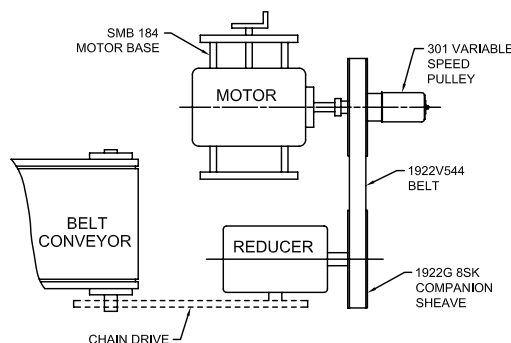

After assembling a complete drive package, you will end up five components: a 301E x 7/8 inch variable speed pulley; a 1922G8SK companion sheave; an SK bushing with a bore to fit the driven shaft; a 1922V544 belt; and a 301 or SMB-184 motor base.

VSD

Aluminoline Selection Example

A variable speed pulley is needed for use on a plastic cut-off machine that indexes material through a guillotine-type shear once every second. Inertia of the shear is not high, but the load is pulsating up to 25% over the motor torque. The motor is rated 1/2 HP @ 1,750 RPM with a NEMA 56 frame (5/8 inch shaft), and a stock (“A” or “B” section) belt is preferred. Good alignment and short center distance is a concern. The driven speed range requirement is 800 to 1,600 RPM.

Step 1: Referring to the Service Factor chart on page VSD-68, a service factor of 1.3 is recommended for pulsating loads. Motor horsepower multiplied by the service factor equals a drive load of 0.65 HP. Either the Econoline or Aluminoline series could be used

with an “A” or “B” section belt, but in this case the Aluminoline is better because it is two-side moveable and will maintain better belt alignment with a short center distance.

Step 2: Both the Models 160 and 170 variable speed pulley are rated for 3/4 HP, which is closest to the drive load of 0.65. In our example, the motor shaft is 5/8 inches, so we can use the Model 160.

Step 3: The Driven Sheave Selection chart for the Model 160 variable speed driver pulley (see page VSD-26) shows that a 6-inch pitch diameter companion sheave will provide a driven speed range of 615 to 1,675 RPM when used with a 1,750 RPM motor. This covers the required driven speed range.

Continued

Step 4: The belt selection chart shows 7.9 inches as the minimum distance for a 160 pulley and a 6 inch sheave. Moving across to the left in that chart, the belt for that center distance is an A33. You can see that the Model 160 pulley requires 2.7 inch travel to achieve full speed range, so the maximum center distance will be 7.9 (minimum cd) + 2.7, or 10.6 inches.

Step 5: A suitable motor base must be selected based on the NEMA motor frame size. For a 56 frame motor, there are several choices: the Model 48/56 economy base, the Model 200 tilting base, the SMB-143 steel sliding base, or on of the two cast iron bases, 145-60 and 135.

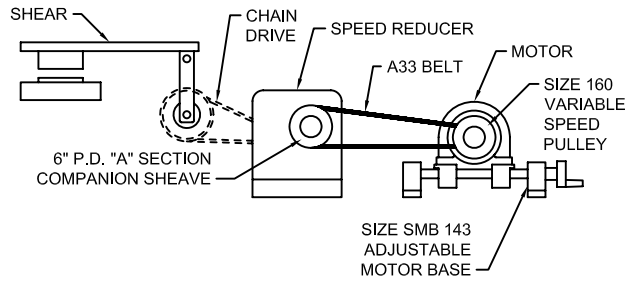

After assembling the complete drive package, you will end up with four components: a 160 x 5/8 inches variable speed pulley; a 6 inch pd companion sheave for an "A" belt with a bore to fit the driven shaft (not supplied by Lovejoy); an A33 drive belt (not supplied by Lovejoy); and a 48/56, 200, SMB-143, 145-60, or 135 motor base.

Selection Examples: Fixed Center Drives

Hexadive Series Selection Example

A fixed center variable speed drive is needed for a centrifugal pump that has an 8 HP peak at 2,000 RPM. The motor is rated for 10 HP @ 1,750 RPM, with a 1-3/8 shaft. The pump shaft is 1-5/8 inches. Shaft center-to-center distance is approximately 16-1/2 inches. There is no room to accommodate an adjustable base or to move the motor back and forth for speed adjustment, so a fixed center drive is preferred. Motor shaft and driven shaft both are oriented in the same direction, so this is a "C" drive configuration. The service factor for a centrifugal pump is 1.0 (see page VSD-68).

Step 1: The Hexadive is selected because of the horsepower requirement. Fixed center drives are rated as constant HP drives from base (motor) speed to maximum driven speed. According to the ratings for 1,750 RPM motors, the drive package most suitable for this 8 HP requirement is a 10 HP drive. Refer to the drive selection data on page VSD-58 for a 10 HP drive.

Step 2: The HM-30 driver is selected, and based on the motor HP, speed, and "C" mounting configuration, the Model 34407 driven pulley is most suitable. This drive is rated at 10 HP from 1,750 to 3,300 RPM driven speed, which is nearest to our 8 HP driven requirement. The Driven Speed chart shows that, with a 1,750 RPM motor, this drive will provide a range of 640 to 3,200 RPM at the pump. A check of stock bore sizes shows that the HM-30 is available in 1-3/8 inches (the motor shaft size), and the 34407 driven pulley is available with a 1-5/8 inch stock bore

Step 3: To select a drive belt, refer to the Belt Selection chart for the HM-30 drive. The 4430V600 belt is chosen because it is closest to the 16-1/2 inch center distance requirement. As the Belt Selection chart shows, the actual center distance is 16.53 inches.

Important Note: When the driven speed range is critical, it is necessary to set up the drive at the exact center distance specified for the belt selected. Any variation from the correct center distance will result in a driven speed range that is different from that shown in the drive selection charts.

Step 4: A Model 501 torque arm bracket is required to prevent rotation of the driver pulley handwheel and allow speed adjustment while the motor is running. If a remote control or linear actuated drive is preferred, the same basic package can be used, but the driver pulley will be a Model HEC-30 for electric remote control (also order the CH-2601 control station) or a Model HEC-30 for electric remote control (also order the CH-2601 control station) or a Model HLA-30 for linear actuation. For details on these pulleys, refer to pages VSD-59 and VSD-60. The 501 torque arm bracket is not necessary when using the HLA pulley.

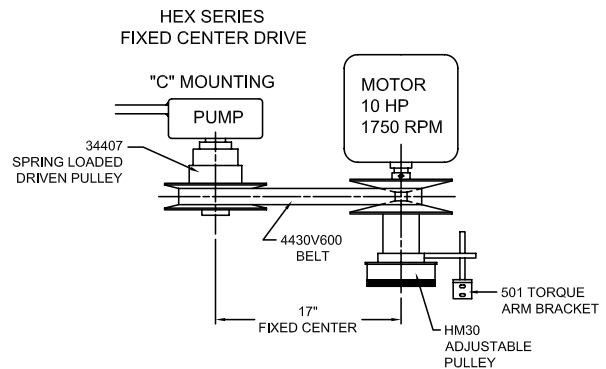

After assembling the complete drive package, you will end up with four components: an HM-30 x 3/8 inch manual driver speed pulley; a 34407 x 5/8 inch spring loaded driven pulley; a 4430V600 belt; and a 501 torque arm bracket.

Variable Speed Drives

Quick Reference List-Adjustable Center Drives

Model	VSD Page	HP Rating		Max Ratio	Style	OAL in	L in	OD in	Belt Type	Weight lbs
		1750 RPM	1150 RPM							
3403	16	1/3	1/4	1.9	1	2.81	.75	3.38	A	2
3405	16	1/2	1/3	1.9	1	2.81	.75	3.38	A	2
4005	16	1/2	1/3	2.3	1	2.81	.75	4.00	A	2
5005A	16	1/2	1/3	1.8	1	3.50	.75	5.00	A	4
5005	17	1/2	1/3	2.7	1	3.50	.81	5.00	B	4
145	25	1/2	1/3	2.0	2	4.81	1.06	4.50	A	2
245	29	1/2	1/3	3.0	2	4.81	1.31	6.00	1422V	3
3407	16	3/4	1/2	1.9	1	2.81	.75	3.38	A	2
4007	16	3/4	1/2	2.3	1	2.81	.75	4.00	A	2
160	26	3/4	1/2	2.8	2	6.31	1.56	6.00	A	3
170	27	3/4	1/2	2.5	2	7.13	1.63	6.31	A or B	4
260	29	3/4	1/2	3.0	2	4.81	1.31	6.00	1422V	3
11407	45	1/2, 3/4	1/3, 1/2	2.6	1	3.56	1.00	6.00	1422V	5
21407	50	1/2, 3/4	1/3, 1/2	2.6	3	4.63	2.50	6.00	1422V	7
4010	16	1	3/4	2.3	1	2.81	.75	4.00	A	2
5010A	16	1	3/4	1.8	1	3.50	.75	5.00	A	4
5010	17	1	3/4	2.7	1	3.50	.81	5.00	B	4
6010	17	1	3/4	2.1	1	4.13	.95	6.00	B	7
7010	17	1	3/4	1.8	1	4.13	.95	7.00	B	8
7210	17	1	3/4	1.6	1	4.38	1.02	8.25	B	10
175	27	1	3/4	2.5	2	7.13	1.63	6.31	A or B	4
2510	23	1	3/4	2.3	3	4.31	2.31	5.00	B	5
11401	45	1	3/4	2.6	1	3.56	1.00	6.00	1422V	5
21401	50	1	3/4	2.6	3	4.63	2.50	6.00	1422V	7
301E	30	1, 1-1/2	3/4, 1	3.0	2	7.13	1.56	7.50	1922V	12
401E	33	1, 1-1/2	3/4, 1	3.8	2	8.75	1.81	11.00	2926V	24
5015A	16	1-1/2	1	1.8	1	3.50	.75	5.00	A	4
5015	17	1-1/2	1	2.7	1	3.50	.81	5.00	B	4
180	27	1-1/2	1	2.5	2	7.13	1.63	6.31	A or B	4
2515	23	1-1/2	1	2.3	3	4.31	2.31	5.00	B	5
11901	46	1-1/2	1	3.0	1	5.38	1.38	8.25	1922V	12
21901	51	1-1/2	1	3.0	3	6.75	3.63	8.25	1922V	12
6020	17	2	1-1/2	2.1	1	4.13	.95	6.00	B	7
7020	17	2	1-1/2	1.8	1	4.13	.95	7.00	B	8
8220	17	2	1-1/2	1.6	1	4.38	1.02	8.25	B	10
2620	23	2	1-1/2	2.1	3	5.47	2.73	6.00	B	8
702E	33	2	1-1/2	3.8	2	8.75	1.81	11.00	2926V	24
11902	46	2	1-1/2	3.0	1	5.38	1.38	8.25	1922V	12
21902	51	2	1-1/2	3.0	3	6.75	3.63	8.25	1922V	12
3030E	31	3	2	3.0	2	8.75	2.00	8.50	2322V	17
303E	32	3	2	3.4	2	8.75	1.81	10.00	2322V	22
6030	17	3	2	2.1	1	4.13	.95	6.00	B	7
7303	17	3	2	1.8	1	4.13	.95	7.00	B	8
8230	17	3	2	1.6	1	4.38	1.02	8.25	B	10
2630	23	3	2	2.1	3	5.47	2.73	6.00	B	8
2730	23	3	2	1.8	3	5.47	2.73	7.00	B	9
11903	46	3	2	3.0	1	5.38	1.38	8.25	1922V	12
21903	51	3	2	3.0	3	6.75	3.63	8.25	1922V	12
403E	33	3	2	3.8	2	8.75	1.81	11.00	2926V	24
7050	17	5	3	1.8	1	4.13	.95	7.00	B	8
8250	17	5	3	1.6	1	4.38	1.02	8.25	B	10
2750	23	5	3	1.8	3	5.47	2.73	7.00	B	9
3050E	34	5	3	3.0	2	10.31	2.13	10.00	2926V	26
12905	47	5	3	3.0	1	6.43	1.88	10.00	2926V	25
22905	52	5	3	3.0	3	8.56	4.56	10.00	2926V	30
3075B	35	7-1/2	5	3.0	2	13.44	2.50	13.00	4430V	49
12907	47	7-1/2	5	3.0	1	6.43	1.88	10.00	2926V	25
22907	52	7-1/2	5	3.0	3	8.56	4.56	10.00	2926V	30
13207	48	7-1/2	5	2.3	1	7.88	2.25	10.75	3230HV	40
23207	53	7-1/2	5	2.3	3	9.38	5.00	10.75	3230HV	43
14407	49	7-1/2	5	2.7	1	8.63	2.38	12.50	4430V	47
24407	54	7-1/2	5	2.7	3	10.13	5.38	12.50	4430V	50

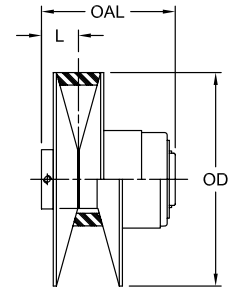

Style 1
One Flange Moveable

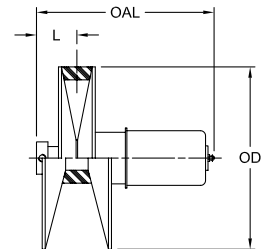

Style 2
Two Flange Moveable

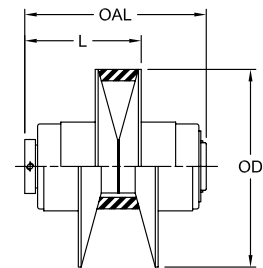

Style 3
Two Flange Moveable

VSD



Variable Speed Drives

Quick Reference List

Selection Data

Variable Speed Drives

Quick Reference List-Adjustable Center Drives

Continued

Model	VSD Page	HP Rating		Max Ratio	Style	OD in	OAL in	L in	Belt Type	Weight lbs
		1750 RPM	1150 RPM							
3100B	33	10	7-1/2	3.0	2	13.00	13.44	2.50	4430V	49
13210	46	10	7-1/2	2.3	1	10.75	7.88	2.25	3230HV	40
23210	51	10	7-1/2	2.3	3	10.75	9.38	5.00	3230HV	43
14410	47	10	7-1/2	2.7	1	12.50	8.63	2.38	4430V	47
24410	52	10	7-1/2	2.7	3	12.50	10.13	5.38	4430V	50
3150B	33	15	10	3.0	2	13.00	13.44	2.50	4430V	49
13220	46	15, 20	10, 15	2.3	1	10.75	7.88	2.25	3230HV	40
23220	51	15, 20	10, 15	2.3	3	10.75	9.38	5.00	3230HV	43
14420	47	15, 20	10, 15	2.7	1	12.50	8.63	2.38	4430V	47
24420	52	15, 20	10, 15	2.7	3	12.50	10.13	5.38	4430V	50
13230	46	25, 30	20, 25	2.3	1	10.75	7.88	2.25	3230HV	40
23230	51	25, 30	20, 25	2.3	3	10.75	9.38	5.00	3230HV	43
14430	47	25, 30	20, 25	2.7	1	12.50	8.63	2.38	4430V	47
24430	52	25, 30	20, 25	2.7	3	12.50	10.13	5.38	4430V	50

Variable Speed Drives

Quick Reference List-Fixed Center Drives

Driver Pulley	Driven Series	VSD Page	HP Rating	Max Ratio	Belt Type
			1750 RPM		
M34 MLA34	3400 / 4000 / 5000A	18-20	Econoline Series 1/3 to 1-1/2	3.7	A
MLA40	4000 / 5000A	18-20	1/2 to 1-1/2	5.3	A
M50	5000 / 6000 / 7000 / 8200		1/2 to 2	7.6	B
MLA50 M60	5000 / 6000 / 7000 / 8200	18-20	1/2 to 3	5.8	B
MLA60 M70 MLA70	5000 / 6000 / 7000 / 8200	18-20	1/2 to 5	4.7	B
WB Series					
M-007	245 / 260	36	1/2 to 3/4	9.3	1422V
M-1	301C / D	37	1 to 1-1/2	9.0	1922V
M-3	3030C / D	37	2 to 3	9.3	2322V
Hi-Ratio Series					
M-14	1400	40	1/2 to 1	8.5	1422V
M-19	1900	41	1 to 3	11.5	1922V
M-23	2300	42	3 to 5	12.1	2322V
Hexadrive Series					
M-007 HEC-007	21407	55 59	1/2 to 3/4	7.6	1422V
HM-3 HEC-3 HLA-3	11900 / 31900	56 59 60	1 to 3	8.8	1922V
HM-7 HEC-7 HLA-7	12900 / 32900	57 29 60	5 to 7-1/2	8.7	2926V
HM-30 HEC-30 HLA-30	14400 / 34400	58 59 60	10 to 30	7.4	4430V

VSD



Variable Speed Drives

Econoline Series

Overview

One-Side Moveable

1/3 Through 5 HP, "A" and "B" Belts

The Econoline Pulley series provides reliable variable speed service with a proven design at an economical cost. The wide selection of models feature compact size and reliability, which make them ideal for both adjustable and fixed center drives in all types of applications using classical "A" and "B" (or 4L and 5L) section drive belts.

Features

- Driven speed ratio up to 7.6 to 1 (fixed center drive)
- Horsepower range from fractional through 5 HP @ 1,750 RPM motor speed
- Maximum bore capacity of 1-1/8 inches
- Flanges made of durable cast iron

Spring-loaded pulleys are through-bored for all types of shaft mounting arrangements. The exposed spring design allows for a cooler running pulley and permits easy cleaning. Complete spring enclosures are available as an option on some models.

Belt Selection

Econoline pulleys are designed specifically for "A" and "B" section drive belts, though they can also be used with "4L" and "5L" belts if necessary. Cogged, raw-edge belts have a definite advantage over wrapped types because they readily form around small pitch diameters, and provide a better arc of contact and provide best possible transmission of torque. If a "slip clutching" effect is desirable to protect machinery in the event of overload, a wrapped belt is recommended.

Adjustable Center Drives

An adjustable center drive using the Econoline variable speed driver pulley is an economical, efficient solution for many drive requirements. The typical adjustable center drive consists of a spring-loaded pulley mounted on the motor shaft, a companion sheave on the driven shaft, an adjustable motor base, and a belt. A wide range of sizes and horsepower ratings are available from the Econoline series to fit the system requirements.

Standard "A" and "B" companion sheaves are recommended for use with Econoline adjustable center drives. Since many Econoline pulleys have only one moveable flange and the companion sheaves are grooved, some misalignment of the belt can be expected and is acceptable for most drives. To minimize this misalignment, the belt should be aligned with the driven sheave when the belt is in the median pitch diameter range of the variable speed pulley, or in the range of principle operation. Due to the minimal bottom contact area of "A" and "B" belts, flat driven sheaves are NOT recommended.



Econoline Series

Fixed Center Drives

Econoline fixed center drives utilize the same type of spring-loaded pulley as an adjustable center drive, only it is normally mounted on the driven shaft. The driver pulley is of similar size and construction, but it is manually adjustable. A fixed center drive offers greater driven speed range in a more compact space. There are two types of controllable pulleys: the M type with a handwheel and built-in adjusting device, and the MLA type that uses an external control. The MLA type pulley can be used with the Lovejoy #76 Control Stand (see page VSD-21) or some other type of linear controller.

A fixed center drive consists of four component parts: the adjustable driver pulley, the spring-loaded driven pulley, the belt, and a Model 501 Torque Arm Bracket. This bracket prevents the handwheel from spinning so speed can be changed while the drive is running (see drawing on page VSD-21). The 501 Torque Arm Bracket is NOT needed with the MLA type pulley.

A wide variety of drive packages are available from the Econoline Series to suit your needs. Different diameter pulleys can be paired together to achieve a variety of driven speed ranges, and all sizes of driven spring-loaded pulleys are available in a variety of horsepower ratings.

Econoline Series

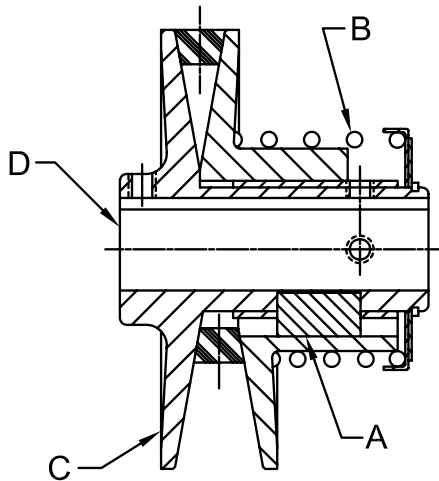

Features

- A Drive Key
- B Precision Calibrated Spring
- C Cast Iron Flanges
- D Thru-bore and Keyway

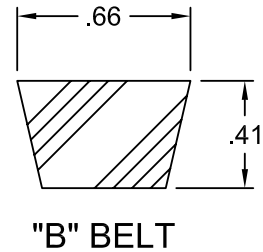
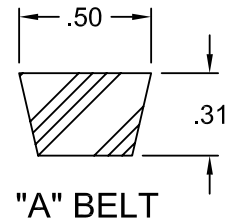

Econoline Series - Inch Bore and Keyway UPC Number Selection Table

Model	Bore and Keyway					
	1/2 No Keyway	5/8 3/16 x 3/32	3/4 3/16 x 3/32	7/8 3/16 x 3/32	1 1/4 x 1/8	1 1/8 1/4 x 1/8
3403	27806	27807	27808	N/A	N/A	N/A
3405	27809	27810	27811	N/A	N/A	N/A
3407	27812	28713	27814	N/A	N/A	N/A
4005	27815	27816	27817	N/A	N/A	N/A
4007	27818	27819	27820	N/A	N/A	N/A
4010	42043	42044	42045	N/A	N/A	N/A
5005A	37368	37369	37370	37371	37372	N/A
5010A	42097	42098	42099	42100	42110	N/A
5015A	42101	42102	42103	42104	42112	N/A
5005	47821	27822	27823	27824	27825	N/A
5010	47096	27093	27094	27095	27826	N/A
5015	27827	27828	27829	27830	27831	N/A
6010	N/A	27832	27833	27834	27835	27836
6020	N/A	27837	27838	27839	27840	27841
6030	N/A	27842	27843	27844	27845	27846
7010	N/A	27848	27849	27850	27851	27852
7020	N/A	27853	27854	27855	27856	27857
7030	N/A	27858	27859	27860	27861	27862
7050	N/A	27863	27864	27865	27866	27867
8210	N/A	27868	27869	27870	27871	27872
8220	N/A	27873	27874	27875	27876	27877
8230	N/A	27878	27879	27880	27881	27882
8250	N/A	27883	27884	27885	27886	27887

Note: ■ When referencing the Lovejoy UPC number in this table, include 685144 as a prefix to the numbers shown.

VSD



Variable Speed Drives

Econoline Spring – Pulley

Dimensional Data

Econoline Series

One-Side Moveable
Adjustable Center Drives
1/4 through 1-1/2 HP “A” Belt

See pages VSD 62-64 for adjustable motor base selection.

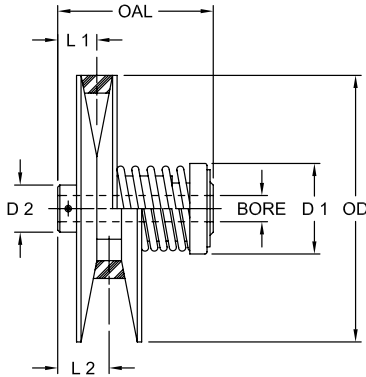

Horsepower Curves – 1,750 RPM Input

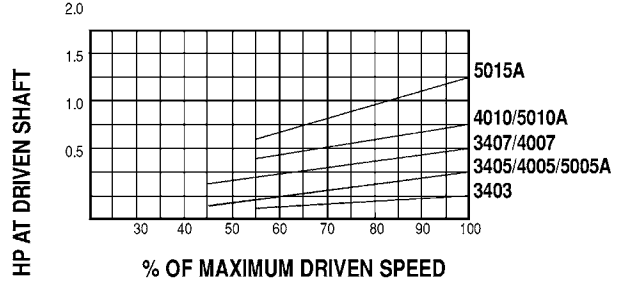

Econoline Spring-Loaded Pulley Dimensional Data

Model	HP Rating		Torque Capacity in-lb	Ratio	PD		Belt Type	OAL in	L1 in	L2 in	OD in	D1 in	D2 in	Stock Thru-Bores					Total Travel in	
	1750 RPM	1150 RPM			Max in	Min in								in	in	in	in	in		in
	RPM	RPM																		
3403	1/3	1/4	12	1.93:1	3.13	1.62	A	2.81	0.75	0.94	3.38	2.16	1.38	1/2	5/8	3/4	—	—	1.2	
3405	1/2	1/3	18											—	—	—	—			
3407	3/4	1/2	27											—	—	—	—			
4005	1/2	1/3	18	2.31:1	3.75	1.62	A	2.81	0.75	0.94	4.00	2.16	1.38	1/2	5/8	3/4	—	—	1.6	
4007	3/4	1/2	27											—	—	—	—			
4010	1	3/4	36											—	—	—	—			
5005A	1/2	1/3	18	1.81:1	4.75	2.62	A	3.50	0.75	0.92	5.00	2.50	1.50	1/2	5/8	3/4	7/8*	1*	1.6	
5010A	1	3/4	36											—	—	—	—			
5015A	1-1/2	1	54											—	—	—	—			

Note: * indicates: That 7/8 and 1 inch bores for 5000 A Series are not thru bores.

Econoline Adjustable Center Drives Sheave and Belt Selection Chart

Driver Pulley	PD Driven Sheave	Driven Speed Range				“A” or “AX” Belt Type													
		1750 RPM Motor		1150 RPM Motor		Minimum Center-to-Center Distance													
		Max RPM	Min RPM	Max RPM	Min RPM	A26	A31	A33	A35	A38	A42	A46	A48	A51	A53	A55	A60	A62	
		in	in	in	in	in	in	in	in	in	in	in	in	in	in	in	in	in	
3400 Series	4.0	1,370	710	900	465	8.0	10.5	11.5	12.5	14.0	16.0	18.0	19.0	20.5	21.5	22.5	25.0	26.0	
	5.0	1,095	570	720	375	7.2	9.7	10.7	11.7	13.2	15.2	17.2	18.2	19.7	20.7	21.7	24.2	25.2	
	6.0	910	475	600	310	6.3	8.9	9.9	10.9	12.4	14.4	16.4	17.4	18.9	19.9	20.9	23.4	24.4	
	8.0	685	355	450	235	—	7.0	8.1	9.1	10.6	12.6	14.7	15.7	17.2	18.2	19.2	21.7	22.7	
	10.0	545	280	360	190	—	—	—	7.2	8.7	10.8	12.8	13.9	15.4	16.4	17.4	20.0	21.0	
	12.0	455	235	300	155	—	—	—	—	—	8.9	10.9	12.0	13.5	14.5	15.6	18.1	19.1	
4000 Series	4.0	1,640	710	1,075	465	7.6	10.1	11.1	12.1	13.6	15.6	17.6	18.6	20.1	21.1	22.1	24.6	25.6	
	5.0	1,310	570	860	375	6.7	9.3	10.3	11.3	12.8	14.8	16.8	17.8	19.3	20.3	21.3	23.8	24.8	
	6.0	1,090	475	715	310	—	8.4	9.4	10.4	11.9	13.9	15.9	16.9	18.4	19.4	20.4	23.0	24.0	
	8.0	820	355	540	235	—	6.6	7.7	8.7	10.2	12.2	14.2	15.2	16.7	17.8	18.8	21.3	22.3	
	10.0	655	280	430	190	—	—	—	—	8.4	10.4	12.5	13.5	15.0	16.0	17.0	19.5	20.5	
	12.0	545	235	360	155	—	—	—	—	—	8.5	10.6	11.6	13.1	14.2	15.2	17.7	18.7	
5000A Series	4.0	2,075	1150	1,365	755	6.8	9.3	10.3	11.3	12.8	14.8	16.8	17.8	19.3	20.3	21.3	23.8	24.9	
	5.0	1,660	920	1,090	605	6.0	8.5	9.5	10.5	12.0	14.0	16.0	17.0	18.5	19.5	20.5	23.0	24.0	
	6.0	1,385	765	910	505	—	7.7	8.7	9.7	11.2	13.2	15.2	16.2	17.7	18.7	19.7	22.2	23.2	
	8.0	1,040	575	680	380	—	—	—	8.0	9.5	11.5	13.5	14.5	16.0	17.0	18.0	20.6	21.6	
	10.0	830	460	545	305	—	—	—	—	7.7	9.7	11.8	12.8	14.3	15.3	16.3	18.8	19.8	
	12.0	690	385	455	255	—	—	—	—	—	—	9.9	11.0	12.5	13.5	14.5	17.1	18.1	

VSD

Econoline Series

One-Side Moveable
 Adjustable Center Drives
 1/3 through 5 HP “B” Belt

See pages VSD 62-64 for adjustable motor base selection.

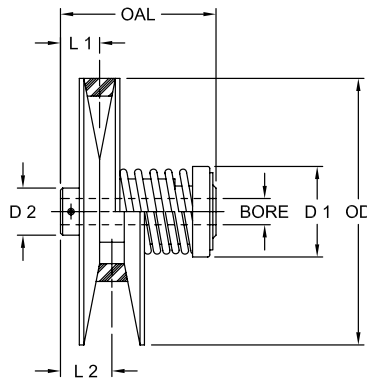

Horsepower Curves – 1,750 RPM Input

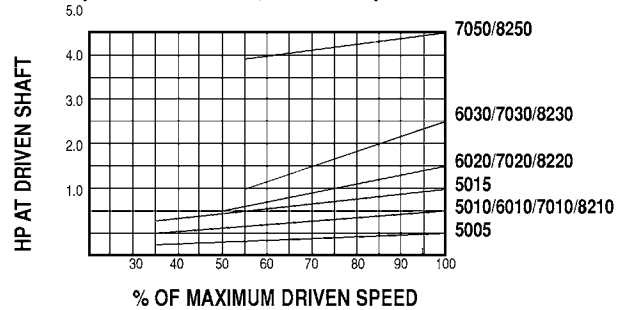

Econoline Spring – Loaded Pulley Dimensional Data

Model	HP Rating		Torque Capacity in-lb	Ratio	PD		Belt Type	OAL in	L1 in	L2 in	OD in	D1 in	D2 in	Stock Thru-Bores					Total Travel in									
	1750 RPM	1150 RPM			Max in	Min in								in	in	in	in	in										
5005	1/2	1/3	18	2.70:1	4.65	1.72	B	3.50	0.81	1.09	5.00	2.50	1.50	1/2	5/8	3/4	7/8*	1*	2.2									
5010	1	3/4	36																									
5015	1-1/2	1	54																									
6010	1	3/4	36	2.10:1	5.65	2.69	B	4.13	0.95	1.19	6.00	3.13	1.88	5/8	3/4	7/8	1	1-1/8	2.2									
6020	2	1-1/2	72																									
6030	3	2	108																									
7010	1	3/4	36	1.80:1	6.65	3.69	B	4.13	0.95	1.19	7.00	3.13	2.88	5/8	3/4	7/8	1	1-1/8	2.2									
7020	2	1-1/2	72																									
7030	3	2	108																									
7050	5	3	180	1.58:1	7.90	5.00	B	4.38	1.02	1.23	8.25	3.13	2.38	5/8	3/4	7/8	1	1-1/8	2.2									
8210	1	3/4	36																									
8220	2	1-1/2	72																									
8230	3	2	108																									
8250	5	3	180																									

Note: * indicates: That 7/8 and 1 inch bores for 5000 Series are not thru bores. Minimum PD = 2.07 inches, Ratio = 2.25:1

Econoline Adjustable Center Drives Sheave and Belt Selection Chart

Driver Pulley	PD Driven Sheave	Driven Speed Range				“B” or “BX” Belt Type													
		1750 RPM Motor		1150 RPM Motor		Minimum Center-to-Center Distance													
		Max RPM	Min RPM	Max RPM	Min RPM	B26	B31	B33	B35	B38	B42	B46	B48	B51	B53	B55	B60	B62	
5000 Series	4.0	2,030	755*	1,330	495*	7.1	9.6	10.6	11.6	13.1	15.1	17.1	18.1	19.6	20.6	21.6	24.1	25.1	
	5.0	1,625	605*	1,060	395*	6.3	8.8	9.8	10.8	12.3	14.3	16.3	17.3	18.8	19.8	20.8	23.3	24.3	
	6.0	1,350	505*	885	330*	—	8.0	9.0	10.0	11.5	13.5	15.5	16.5	18.0	19.0	20.0	22.5	23.5	
	8.0	1,015	380*	665	250*	—	—	7.3	8.3	9.8	11.8	13.8	14.9	16.4	17.4	18.4	20.9	21.9	
	10.0	810	305*	530	200*	—	—	—	—	8.0	10.1	12.1	13.1	14.6	15.6	16.6	19.2	20.2	
6000 Series	5.0	1,975	945	1,300	620	—	8.0	9.0	10.0	11.5	13.5	15.5	16.5	18.0	19.0	20.0	22.5	23.5	
	6.0	1,645	790	1,080	520	—	7.2	8.2	9.2	10.7	12.7	14.7	15.7	17.2	18.2	19.2	21.7	22.7	
	8.0	1,230	590	810	390	—	—	—	7.6	9.1	11.1	13.1	14.1	15.6	16.6	17.6	20.1	21.1	
	10.0	985	475	645	310	—	—	—	—	9.4	11.4	13.4	14.4	15.9	16.9	17.9	19.4	20.4	
	12.0	820	395	540	260	—	—	—	—	—	9.6	11.6	13.6	14.6	16.1	17.1	18.6	19.6	
7000 Series	6.0	1,930	1,080	1,270	710	—	—	7.5	8.5	10.0	12.0	14.0	15.0	16.5	17.5	18.5	21.0	22.0	
	7.0	1,660	925	1,090	610	—	—	—	7.7	9.2	11.2	13.2	14.2	15.7	16.7	17.7	20.2	21.2	
	8.0	1,450	810	950	535	—	—	—	—	8.4	10.4	12.4	13.4	14.9	15.9	16.9	19.4	20.4	
	10.0	1,160	650	760	425	—	—	—	—	—	10.7	12.7	13.7	15.2	16.2	17.2	19.7	20.7	
	12.0	965	540	635	355	—	—	—	—	—	—	10.0	11.5	12.5	13.5	14.5	17.0	18.0	
8200 Series	6.0	2,300	1,460	1,500	960	—	—	—	7.4	8.9	10.9	12.9	13.9	15.4	16.5	17.5	20.0	21.0	
	8.0	1,725	1,100	1,130	720	—	—	—	—	9.4	11.4	13.4	14.4	15.9	16.9	18.4	19.4		
	10.0	1,380	880	900	580	—	—	—	—	—	9.8	11.8	12.8	14.3	15.3	16.8	17.8		
	12.0	1,150	730	750	480	—	—	—	—	—	—	—	10.6	11.6	12.6	15.1	16.1		

Note: * indicates: Except on 7/8 and 1 inch bores.



Variable Speed Drives

Econoline M Type – Inch Bore / Keyway

Item Selection

Econoline Series

Fixed Center Drives
1/3 through 5 HP
“A” and “B” Belts

The Econoline fixed center drive uses a driver pulley that is manually adjustable. (Refer to the description of Econoline fixed center drives on page VSD-14). There are two types of controllable pulleys: the M type with a handwheel and built-in adjusting device, and the MLA type that uses an external control. The MLA type pulley can be used with the Lovejoy Model 76 Control Stand or some other type of linear controller.



Econoline M Type

Econoline M Type Manual Pulleys - Inch Bore and Keyway UPC Number Selection Table

Model	Pd		HP Range ¹	Belt Type	Bore and Keyway					
	Max in	Min in			1/2 No Keyway	5/8 3/16 x 3/32	3/4 3/16 x 3/32	7/8 3/16 x 3/32	1 1/4 x 1/8	1-1/8 1/4 x 1/8
M-34	3.13	1.62	1/3-3/4	A	31582	35183	31584	N/A	N/A	N/A
M-50	4.65	1.60	1/2-2	B	31586	31587	31588	31589	N/A	N/A
M-60	5.65	2.34	1/2-3	B	N/A	31617	31618	31619	31620	31621
M-70	6.65	3.34	1/2-5	B	N/A	37299	37300	37301	37302	37303

- Notes: ■ 1 indicates: Horsepower and torque rating of each of these pulleys is dependent upon the driven spring-loaded pulley with which it is matched. Refer to Drive Selection chart on page VSD-19 for details.
 ■ When referencing the Lovejoy UPC number in this table, include 685144 as a prefix to the numbers shown.

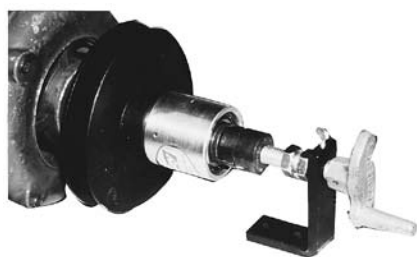

Econoline MLA Type

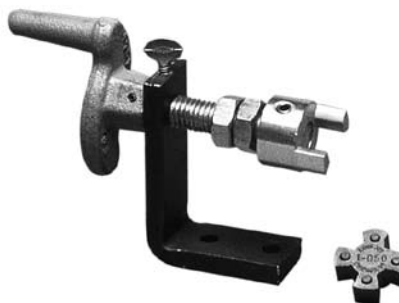

Model 76 Control Stand
[Lovejoy UPC number 20021]

Econoline MLA Type Manual Pulleys - Inch Bore and Keyway UPC Number Selection Table

Model	Pd		HP Range ¹	Belt Type	Bore and Keyway					
	Max in	Min in			1/2 No Keyway	5/8 3/16 x 3/32	3/4 3/16 x 3/32	7/8 3/16 x 3/32	1 1/4 x 1/8	1-1/8 1/4 x 1/8
MLA-34	3.13	1.62	1/3-3/4	A	42591	42904	42905	N/A	N/A	N/A
MLA-40	3.75	1.62	1/2-1-1/2	A	42906	42581	42907	N/A	N/A	N/A
MLA-50	4.65	1.60	1/2-2	B	42908	42909	42910	42911	N/A	N/A
MLA-60	5.65	2.34	1/2-3	B	N/A	42912	42913	42914	42915	42916
MLA-70	6.65	3.34	1/2-5	B	N/A	42917	42918	42919	42920	42921

- Notes: ■ 1 indicates: Horsepower and torque rating of each of these pulleys is dependent upon the driven spring-loaded pulley with which it is matched. Refer to Drive Selection chart on page VSD-19 for details.
 ■ When referencing the Lovejoy UPC number in this table, include 685144 as a prefix to the numbers shown.

VSD



Variable Speed Drives

Econoline M and MLA Type

Item Selection

Econoline Series

Fixed Center Drives
1/3 through 5 HP
"A" and "B" Belts

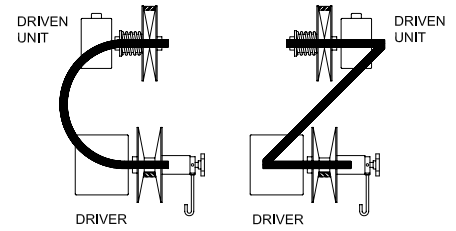

Econoline M and MLA Drive Selection Table

Pulley Model Combinations			Ratio	HP Ratings with 1750 RPM Motor		Driven Speed Ranges 1750 RPM Motor*		Max Torque Of Driven Pulley in-lb	Belt Type
Driver Manual	Driven Spring-Loaded			Rating At 1750 To Max RPM of Driven Pulley HP	HP Rating At Min RPM of Driven Pulley HP	Min RPM	Max RPM		
	"Z"	"C"							
M34 or MLA34	3403	3403R	3.7:1	0.33	0.17	910	3380	12	A
	3405	3405R		0.50	0.25			18	
	3407	3407R		0.75	0.39			27	
M34 or MLA34	4005	4005R	3.0:1	0.50	0.22	760	2300	18	A
	4007	4007R		0.75	0.32			27	
M34 or MLA34	5005A	5005AR	2.6:1	0.50	0.17	600	1540	18	A
	5010A	5010AR		1.00	0.34			36	
	5015A	5015AR		1.50	0.51			54	
MLA40	4005	4005R	5.3:1	0.50	0.22	760	4050	18	A
	4007	4007R		0.75	0.32			27	
MLA40	5005A	5005AR	3.8:1	0.50	0.27	600	2280	18	A
	5010A	5010AR		1.00	0.55			36	
	5015A	5015AR		1.50	0.83			54	
M50 or MLA50	5005	5005R	7.6:1	0.50	0.17	610	4640	18	B
	5010	5010R		1.00	0.34			36	
	5015	5015R		1.50	0.52			51	
M50 or MLA50	6010	6010R	5.5:1	1.00	0.28	500	2760	36	B
	6020	6020R		2.00	0.57			72	
M50 or MLA50	7010	7010R	4.5:1	1.00	0.24	430	1940	36	B
	7020	7020R		2.00	0.48			72	
M50 or MLA50	8210	8210R	4.0:1	1.00	0.20	360	1440	36	B
	8220	8220R		2.00	0.41			72	
M60 or MLA60	5005	5005R	5.8:1	0.50	0.25	890	5190	18	B
	5010	5010R		1.00	0.50			36	
	5015	5015R		1.50	0.75			54	
M60 or MLA60	6010	6010R	4.8:1	1.00	0.41	730	3500	36	B
	6020	6020R		2.00	0.82			72	
	6030	6030R		3.00	1.23			108	
M60 or MLA60	7010	7010R	4.3:1	1.00	0.35	620	2660	36	B
	7020	7020R		2.00	0.70			72	
	7030	7030R		3.00	1.06			108	
M60 or MLA60	8210	8210R	3.7:1	1.00	0.29	520	1910	36	B
	8220	8220R		2.00	0.59			72	
	8230	8230R		3.00	0.89			108	
M70 or MLA70	5005	5005R	4.7:1	0.50	0.36	1260	5990	18	B
	5010	5010R		1.00	0.72			36	
	5015	5015R		1.50	1.08			54	
M70 or MLA70	6010	6010R	3.8:1	1.00	0.59	1040	4000	36	B
	6020	6020R		2.00	1.19			72	
	6030	6030R		3.00	1.78			108	
M70 or MLA70	7010	7010R	3.4:1	1.00	0.50	880	3020	36	B
	7020	7020R		2.00	0.99			72	
	7030	7030R		3.00	1.49			108	
	7050	7050R		5.00	2.49			180	
M70 or MLA70	8210	8210R	3.1:1	1.00	0.42	750	2360	36	B
	8220	8220R		2.00	0.83			72	
	8230	8230R		3.00	1.25			108	
	8250	8250R		5.00	2.09			180	

Note: ■ * indicates: The driven speed ranges and resulting ratios shown in this chart are derived from mathematical calculations based upon exact center distance, constant motor speed and manufacturers' belt specifications. Actual results will differ due to variations in any of these factors. TO FIND THE DRIVEN SPEED RANGE WITH AN 1,150 RPM MOTOR, MULTIPLY BY 0.666.



Variable Speed Drives

Econoline Fixed Center

Item Selection

Econoline Series

Fixed Center Drives
1/3 through 5 HP
"A" and "B" Belts

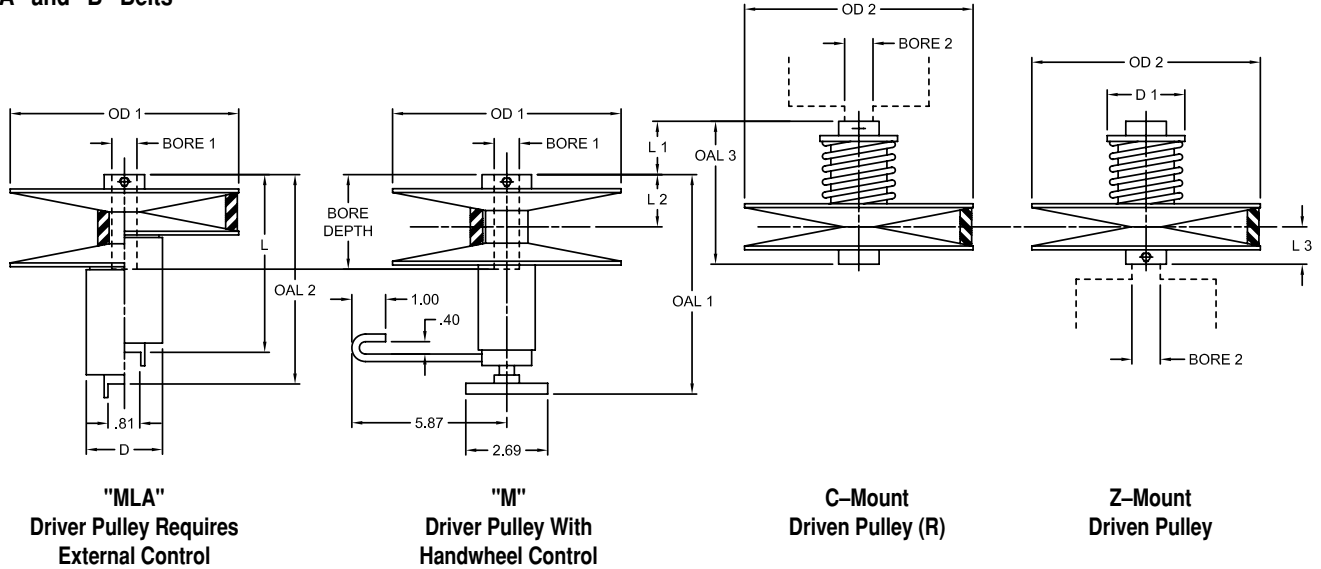

Econoline Fixed Center Dimensional Data

Driver Pulley	Model		Belt Size	Stock Bore										OD1 in	OAL1 in	L2 in	Bore Depth in	OD2 in	OAL3 in	L3 in	D1 in	L1 in	OAL2 in	L in	D in
	Driven Pulley			Manual Bore1					Spring-Loaded Bore2																
	"C"	"Z"		in					in																
M34 or MLA34	3400-R	3400	A	1/2	5/8	3/4	—	—	1/2	5/8	3/4	—	—	3.38	5.38	0.94	1.69	3.38	2.81	0.75	2.16	1.12	4.28	3.94	2.25
	4000-R	4000	A	1/2	5/8	3/4	—	—	1/2	5/8	3/4	—	—	3.38	5.38	0.94	1.69	4.00	2.81	0.75	2.16	1.12	4.28	3.94	2.25
MLA40	5000A-R	5000A	A	1/2	5/8	3/4	—	—	1/2	5/8	3/4	7/8	—	3.38	5.38	0.94	1.69	5.00	3.50	0.75	2.50	1.81	4.28	3.94	2.25
	4000-R	4000	A	1/2	5/8	3/4	—	—	1/2	5/8	3/4	—	—	4.00	N/A	0.94	2.50	4.00	2.81	0.75	2.16	1.12	3.56	3.12	2.00
MLA40	5000A-R	5000A	A	1/2	5/8	3/4	—	—	1/2	5/8	3/4	7/8	—	4.00	N/A	0.94	2.50	5.00	3.50	0.75	2.50	1.81	3.56	3.12	2.00
	4000-R	4000	A	1/2	5/8	3/4	—	—	1/2	5/8	3/4	—	—	4.00	N/A	0.94	2.50	4.00	2.81	0.75	2.16	1.12	3.56	3.12	2.00
M50 or MLA50	5000-R	5000	B	1/2	5/8	3/4	7/8	—	1/2	5/8	3/4	7/8	—	5.00	5.69	1.06	2.00	5.00	3.50	0.81	2.50	1.62	4.62	4.12	2.25
	6000-R	6000	B	1/2	5/8	3/4	7/8	—	5/8	3/4	7/8	1	1-1/8	5.00	5.69	1.06	2.00	6.00	4.12	0.95	3.00	2.12	4.62	4.12	2.25
	7000-R	7000	B	1/2	5/8	3/4	7/8	—	5/8	3/4	7/8	1	1-1/8	5.00	5.69	1.06	2.00	7.00	4.12	0.95	3.00	2.12	4.62	4.12	2.25
	8200-R	8200	B	1/2	5/8	3/4	7/8	—	5/8	3/4	7/8	1	1-1/8	5.00	5.69	1.06	2.00	8.25	4.38	1.02	3.00	2.30	4.62	4.12	2.25
M60 or MLA60	5000-R	5000	B	5/8	3/4	7/8	1	1-1/8	1/2	5/8	3/4	7/8	—	6.00	6.69	1.23	2.75	5.00	3.50	0.81	2.50	1.46	5.50	5.00	2.75
	6000-R	6000	B	5/8	3/4	7/8	1	1-1/8	5/8	3/4	7/8	1	1-1/8	6.00	6.69	1.23	2.75	6.00	4.12	0.95	3.00	1.95	5.50	5.00	2.75
	7000-R	7000	B	5/8	3/4	7/8	1	1-1/8	5/8	3/4	7/8	1	1-1/8	6.00	6.69	1.23	2.75	7.00	4.12	0.95	3.00	1.95	5.50	5.00	2.75
	8200-R	8200	B	5/8	3/4	7/8	1	1-1/8	5/8	3/4	7/8	1	1-1/8	6.00	6.69	1.23	2.75	8.25	4.38	1.02	3.00	2.12	5.50	5.00	2.75
M70 or MLA70	5000-R	5000	B	5/8	3/4	7/8	1	1-1/8	1/2	5/8	3/4	7/8	—	7.00	6.69	1.23	2.75	5.00	3.50	0.81	2.50	1.46	5.50	5.00	2.75
	6000-R	6000	B	5/8	3/4	7/8	1	1-1/8	5/8	3/4	7/8	1	1-1/8	7.00	6.69	1.23	2.75	6.00	4.12	0.95	3.00	1.95	5.50	5.00	2.75
	7000-R	7000	B	5/8	3/4	7/8	1	1-1/8	5/8	3/4	7/8	1	1-1/8	7.00	6.69	1.23	2.75	7.00	4.12	0.95	3.00	1.95	5.50	5.00	2.75
	8200-R	8200	B	5/8	3/4	7/8	1	1-1/8	5/8	3/4	7/8	1	1-1/8	7.00	6.69	1.23	2.75	8.25	4.38	1.02	3.00	2.12	5.50	5.00	2.75

VSD

Econoline Series

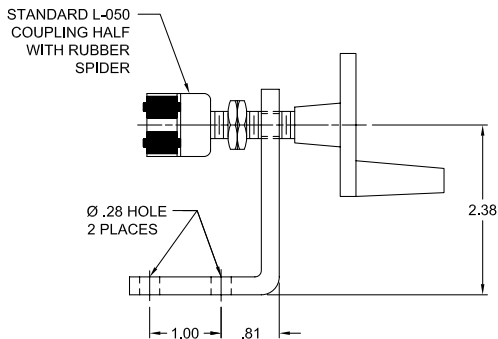

Model 76 Control Stand Assembly

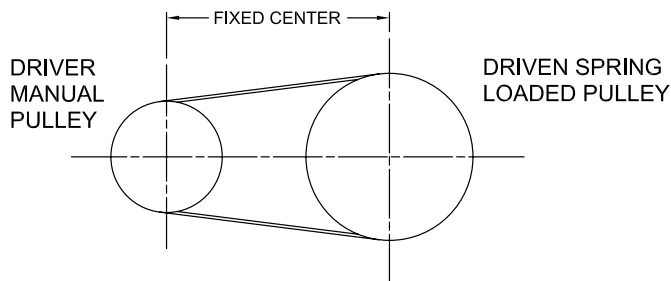

MOTOR BASE NOT REQUIRED

Center-To-Center Distance

Econoline Fixed Center Drives Belt Selection Table

Driver Pulley	Driven Pulley	Belt Size	Belt Size ² Center-to-Center Distance												
			26 in	31 in	33 in	35 in	38 in	42 in	46 in	48 in	51 in	53 in	56 in	60 in	62 in
M34 or MLA34	3400	A	9.9	12.4	13.4	14.4	15.9	17.9	19.9	20.9	22.4	23.4	24.4	26.9	27.9
	4000	A	9.3	11.9	12.9	13.9	15.4	17.4	19.4	20.4	21.9	22.9	23.9	26.4	27.4
	5000A	A	8.5	11.0	12.0	13.0	14.5	16.5	18.5	19.5	21.1	22.1	23.1	25.6	26.6
MLA40	4000	A	9.3	11.9	12.9	13.9	15.4	17.4	19.4	20.4	21.9	22.9	23.9	26.4	27.4
	5000A	A	8.5	11.0	12.0	13.0	14.5	16.5	18.5	19.5	21.1	22.1	23.1	25.6	26.6
M50 or MLA50	5000	B	8.8	11.3	12.4	13.4	14.9	16.9	18.9	19.9	21.4	22.4	23.4	25.9	26.9
	6000	B	7.9	10.5	11.5	12.5	14.0	16.0	18.0	19.0	20.6	21.6	22.6	25.1	26.1
	7000	B	7.0	9.5	10.6	11.6	13.1	15.1	17.2	18.2	19.7	20.7	21.7	24.2	25.2
	8200	B	—	8.3	9.4	10.4	11.9	14.0	16.0	17.0	18.6	19.6	20.6	23.1	24.1
M60 or MLA60	5000	B	8.3	10.8	11.8	12.8	14.3	16.3	18.4	19.4	20.9	21.9	22.9	25.4	26.4
	6000	B	7.4	10.0	11.0	12.0	13.5	15.5	17.5	18.5	20.0	21.0	22.0	24.5	25.5
	7000	B	—	9.1	10.1	11.1	12.6	14.6	16.6	17.7	19.2	20.2	21.2	23.7	24.7
	8200	B	—	7.9	8.9	9.9	11.5	13.5	15.5	16.5	18.1	19.1	20.1	22.6	23.6
M70 or MLA70	5000	B	7.6	10.1	11.1	12.1	13.6	15.6	17.6	18.6	20.1	21.1	22.1	24.6	25.6
	6000	B	—	9.3	10.3	11.3	12.8	14.8	16.8	17.8	19.3	20.3	21.3	23.8	24.8
	7000	B	—	8.4	9.4	10.4	11.9	13.9	15.9	16.9	18.5	19.5	20.5	23.0	24.0
	8200	B	—	—	8.3	9.3	10.8	12.8	14.9	15.9	17.4	18.4	19.4	21.9	22.9

Notes: ■ 2 indicates: "Belt Size" is NOT the same as belt pitch length, but refers to the Industry Standard length designation. For example, the M50/6000 drive package with a center distance of 12.5 inches would use a B35 belt.

■ Center distances are based on installation with the belt in the Minimum PD position of the driver pulley and at the Maximum PD of the driven pulley.

501 Torque Arm Bracket

Fixed center drive assemblies require a torque arm bracket to prevent the handwheel from spinning. This allows speed to be changed while the drive is running. This bracket may be used with Econoline, WB, Hi-Ratio, and Hexadrive Fixed Center Drives. Bracket is NOT needed with the MLA type pulley. For ordering, use Lovejoy UPC number 685144 19952.

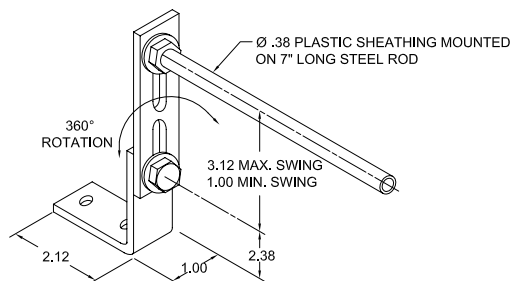

Model 501 Torque Arm Bracket



Variable Speed Drives

Econoline Two Sided – Inch Bore / Keyway

Item Selection

Econoline Series

Two-Side Moveable

Our new two-side moveable Econoline pulleys are ideal for adjustable center applications where shaft-to-shaft distances are very short and belt misalignment cannot be tolerated, or in those instances where this style needs replacement.

Features

- Three diameters (5, 6 and 7 inches)
- Six models, rated for 1 through 5 HP @ 1,750 RPM
- Speed ratios up to 2.3 to 1
- Durable cast iron flanges
- Use with standard “B” section drive belts
- Belt alignment is maintained at all speeds



Econoline Two-Side Moveable

Econoline Two Side Moveable Spring-Loaded Pulleys - Inch Bore and Keyway UPC Number Selection Table

Model	Bore & Keyway				
	5/8 3/16 x 3/32	3/4 3/16 x 3/32	7/8 3/16 x 3/32	1 1/4 x 1/8	1-1/8 1/4 x 1/8
2510	57606	57607	57608	N/A	N/A
2515	57599	57600	57601	N/A	N/A
2620	57643	57644	57645	57646	57647
2630	57648	57649	57650	57651	57652
2730	57617	57618	57619	57620	57621
2750	57622	57623	57624	57625	57626

Note: ■ When referencing the Lovejoy UPC number in this table, include 685144 as a prefix to the numbers shown.



Variable Speed Drives

Econoline Two Sided – Adjustable Center / Belts

Item Selection

Econoline Series

Two-Side Moveable
Adjustable Center Drives
3/4 through 5 HP
"B" Belt

See pages VSD 62-64 for
adjustable motor base selection.

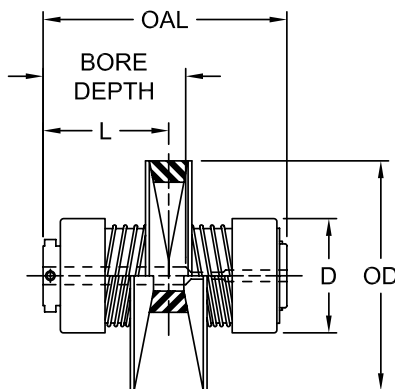

Horsepower Curves – 1750 RPM Input

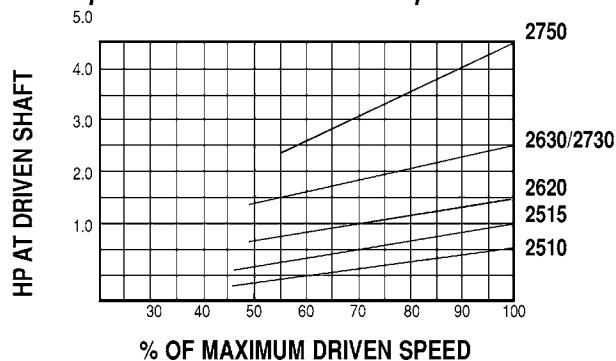

Econoline Two-Side Moveable Dimensional Data

HP Rating RPM		Model	Torque Capacity in-lb	Ratio	PD		Belt Size	OAL in	L in	OD in	D in	Bore Depth in	Stock Thru-Bores					Total Travel in
1750	1150				Max in	Min in							in	in	in	in	in	
1	3/4	2510	36	2.3:1	4.65	2.00	B	4.06	2.18	5.00	2.67	2.50	5/8	3/4	7/8	—	—	1.9
1-1/2	1	2515	54	2.3:1	4.65	2.00	B	4.06	2.18	5.00	2.67	2.50	5/8	3/4	7/8	—	—	1.9
2	1-1/2	2620	72	2.1:1	5.65	2.69	B	5.06	2.53	6.00	3.13	3.50	5/8	3/4	7/8	1	1-1/8	2.2
3	2	2630	108	2.1:1	5.65	2.69	B	5.06	2.53	6.00	3.13	3.50	5/8	3/4	7/8	1	1-1/8	2.2
3	2	2730	108	1.8:1	6.65	3.69	B	5.06	2.53	7.00	3.13	3.50	5/8	3/4	7/8	1	1-1/8	2.2
5	3	2750	180	1.8:1	6.65	3.69	B	5.06	2.53	7.00	3.13	3.50	5/8	3/4	7/8	1	1-1/8	2.2

Econoline Adjustable Center Drives Sheave and Belt Selection Table

Driver Pulley	PD Driven Sheave in	Driven Speed Range				"B" or "BX" Belt Size													
		1750 RPM Motor		1150 RPM Motor		Minimum Center-to-Center Distance													
		Max RPM	Min RPM	Max RPM	Min RPM	B26 in	B31 in	B33 in	B35 in	B38 in	B42 in	B46 in	B48 in	B51 in	B53 in	B55 in	B60 in	B62 in	
2510 or 2515	4.0	2,030	880	1,330	580	7.1	9.6	10.6	11.6	13.1	15.1	17.1	18.1	19.6	20.6	21.6	24.1	25.1	
	5.0	1,620	700	1,060	460	6.3	8.8	9.8	10.8	12.3	14.3	16.3	17.3	18.8	19.8	20.8	23.3	24.3	
	6.0	1,350	590	890	390	—	8.0	9.0	10.0	11.5	13.5	15.5	16.5	18.0	19.0	20.0	22.5	23.5	
	8.0	1,010	440	660	290	—	—	7.3	8.3	9.8	11.8	13.8	14.9	16.4	17.4	18.4	20.9	21.9	
	10.0	810	350	530	230	—	—	—	—	8.0	10.1	12.1	13.1	14.6	15.6	16.6	19.0	20.2	
2620 or 2630	12.0	670	300	440	200	—	—	—	—	—	—	10.3	11.3	12.8	13.8	14.8	17.4	18.4	
	5.0	1,970	950	1,290	620	—	8.0	9.0	10.0	11.5	13.5	15.5	16.5	18.0	19.0	20.0	22.5	23.5	
	6.0	1,640	790	1,080	520	—	7.2	8.2	9.2	10.7	12.7	14.7	15.7	17.2	18.2	19.2	21.7	22.7	
	8.0	1,230	590	810	390	—	—	—	7.6	9.1	11.1	13.1	14.1	15.6	16.6	17.6	20.1	21.1	
	10.0	980	480	640	310	—	—	—	—	9.4	11.4	12.4	13.9	14.9	15.9	18.5	19.5		
2730 or 2750	12.0	820	400	540	260	—	—	—	—	—	—	9.6	10.6	12.2	13.2	14.2	16.7	17.7	
	6.0	1,930	1,080	1,270	710	—	—	7.5	8.5	10.0	12.0	14.0	15.0	16.5	17.5	18.5	21.0	22.0	
	7.0	1,660	930	1,090	610	—	—	—	7.7	9.2	11.2	13.2	14.2	15.7	16.7	17.7	20.2	21.2	
	8.0	1,450	810	950	530	—	—	—	—	8.4	10.4	12.4	13.4	14.9	15.9	16.9	19.4	20.4	
	10.0	1,160	650	760	430	—	—	—	—	—	—	10.7	11.7	13.2	14.2	15.2	17.7	18.7	
12.0	960	540	630	360	—	—	—	—	—	—	—	10.0	11.5	12.5	13.5	16.0	17.0		

VSD



Variable Speed Drives

Aluminoline Series

Overview

Aluminoline Series

Two-Side Moveable
1/3 through 1-1/2 HP
“A” and “B” Belts

Aluminoline variable speed pulleys are designed for the best possible belt alignment with the least amount of overhung load. Flanges are made of a lightweight, corrosion-resistant aluminum, which is hard-coat anodized for long life. The aluminum flanges provide quiet operation with minimum vibration. These pulleys are used with classical “A” and “B” drive belts.

Aluminoline pulleys offer maximum service when lubricated through a convenient grease fitting located on the end of the pulley shaft.

Features

- Ratings for 1/3 through 1-1/2 HP motors
- Unique “intermeshing” flange design
- Greater speed ratios (up to 2.75 to 1) with a narrow-belt adjustable center drive than any other pulley

Belt Selection

Aluminoline variable speed pulleys are designed to drive standard “A” and “B” section belts. Due to the intermeshing flange design, it is best to use a wrapped belt or one without cogs.

Adjustable Center Drives

The typical adjustable center drive consists of the Aluminoline pulley mounted on the motor shaft, a companion sheave on the driven shaft, an adjustable motor base and a belt. Standard “A” and “B” fixed diameter sheaves should be used as driven companion sheaves. Belt alignment will be maintained throughout the speed range because the Aluminoline pulleys are two-side moveable. Due to the minimal bottom contact area of “A” and “B” belts, flat driven sheaves are NOT recommended.



Aluminoline Series Pulley



Typical “V-V” Adjustable Center Drive



Variable Speed Drives

Aluminoline Models 145 and 145-HD

Item Selection

Aluminoline Series

Two-Side Moveable
Adjustable Center Drives
1/3 through 3/4 HP
"A" Belt

Ratio 2 to 1

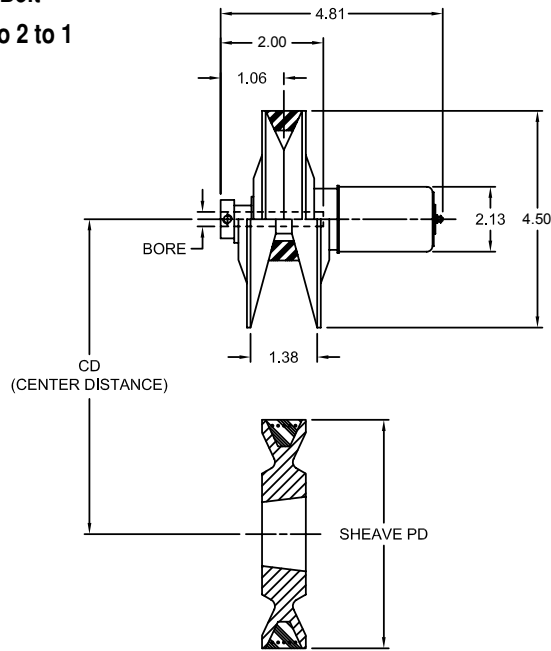

Model 145 Spring-Loaded Driver Pulley

UPC Number	Bore in	PD		Torque Capacity in-lb	HP Rating	
		Min in	Max in		1750 RPM	1150 RPM
18523	1/2	2.10	4.25	18	1/2	1/3
18525	5/8					
18526	3/4					

Model 145-HD Spring-Loaded Driver Pulley

UPC Number	Bore in	PD		Torque Capacity in-lb	HP Rating	
		Min in	Max in		1750 RPM	1150 RPM
42156	1/2	2.10	4.25	27	3/4	1/2
18533	5/8					
42157	3/4					

Note: ■ When referencing the Lovejoy UPC number in this table, include 685144 as a prefix to the numbers shown in the tables.

Horsepower Curves - 1,750 RPM Input

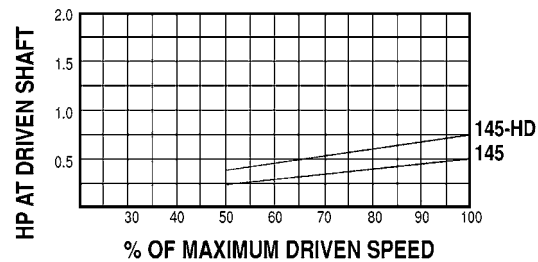

145 / 145-HD Driven Sheave Selection Table

PD Driven Sheave in	Driven Speed Range				Driven Torque	
	1750 RPM Motor		1150 RPM Motor		145 in-lb	145-HD in-lb
	Min RPM	Max RPM	Min RPM	Max RPM		
4.0	920	1,855	605	1,220	17	19
5.0	735	1,485	485	975	21	24
6.0	615	1,235	405	810	25	28
8.0	460	925	305	610	34	38
10.0	370	740	245	485	42	48
12.0	310	615	205	405	50	56

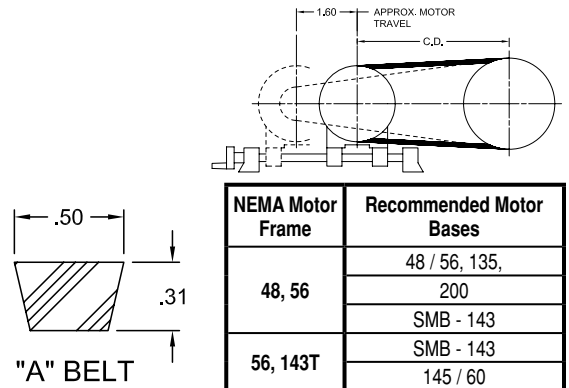

NEMA Motor Frame	Recommended Motor Bases
48, 56	48 / 56, 135, 200
	SMB - 143
56, 143T	SMB - 143
	145 / 60

145 / 145-HD Belt Selection Chart

PD Driven Sheave in	Minimum Center Distance by Selected Sheave Size "A" Belt Size ¹													
	A26 (27.3) in	A31 (32.3) in	A33 (34.3) in	A35 (36.3) in	A38 (39.3) in	A42 (43.3) in	A46 (47.3) in	A48 (49.3) in	A51 (52.3) in	A53 (54.3) in	A55 (56.3) in	A60 (61.3) in	A62 (63.3) in	
4.0	7.2	9.7	10.7	11.7	13.2	15.2	17.2	18.2	19.7	20.7	21.7	24.2	25.2	
5.0	6.4	8.9	9.9	10.9	12.4	14.4	16.4	17.4	18.9	19.9	20.9	23.4	24.4	
6.0	—	8.1	9.1	10.1	11.6	13.6	15.6	16.6	18.1	19.1	20.1	22.6	23.6	
8.0	—	—	7.3	8.3	9.8	11.9	13.9	14.9	16.4	17.4	18.4	20.9	21.9	
10.0	—	—	—	—	8.0	10.1	12.1	13.1	14.6	15.7	16.7	19.2	20.2	
12.0	—	—	—	—	—	—	10.3	11.3	12.8	13.8	14.9	17.4	18.4	

Note: ■ 1 indicates: These are nominal belt sizes. The number in parentheses is the actual pitch length.



Variable Speed Drives

Aluminoline Models 160 and 160-HD

Item Selection

Aluminoline Series

Two-Side Moveable
Adjustable Center Drives
1/2 through 1 HP
"A" Belt

Ratio 2.7:1

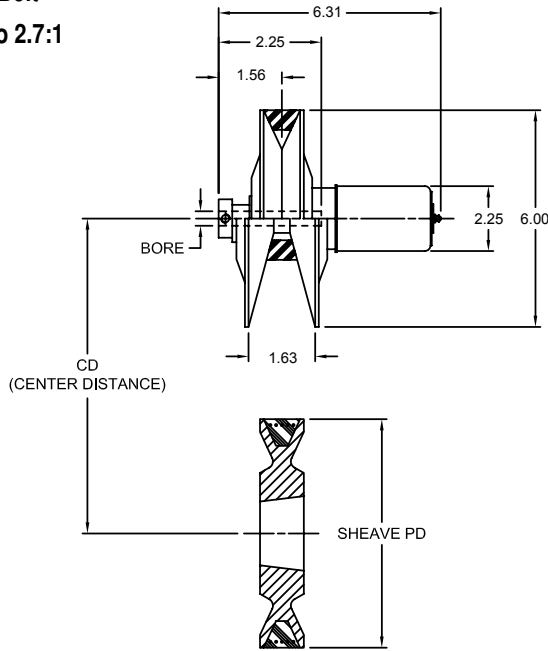

Model 160 Spring-Loaded Driver Pulley

UPC Number	Bore in	PD		Torque Capacity in-lb	HP Rating	
		Min in	Max in		1750 RPM	1150 RPM
18572	1/2	2.10	5.75	27	3/4	1/2
18573	5/8					
18574	3/4					

Model 160-HD Spring-Loaded Driver Pulley

UPC Number	Bore in	PD		Torque Capacity in-lb	HP Rating	
		Min in	Max in		1750 RPM	1150 RPM
42184	1/2	2.10	5.75	36	1	3/4
42185	5/8					
42087	3/4					

Note: ■ When referencing the Lovejoy UPC number in this table, include 685144 as a prefix to the numbers shown in the tables.

Horsepower Curves – 1,750 RPM Input

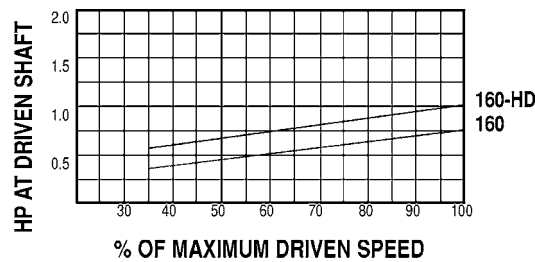

160 / 160-HD Driven Sheave Selection Table

PD Driven Sheave in	Driven Speed Range				Driven Torque	
	1750 RPM Motor		1150 RPM Motor		160 in-lb	160-HD in-lb
	Min RPM	Max RPM	Min RPM	Max RPM		
4.0	920	2,515	605	1,650	19	24
5.0	735	2,010	485	1,320	24	30
6.0	615	1,675	405	1,100	28	36
8.0	460	1,255	305	825	38	48
10.0	370	1,005	245	660	47	60
12.0	310	835	205	550	56	75

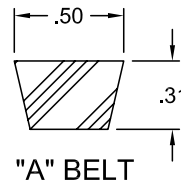
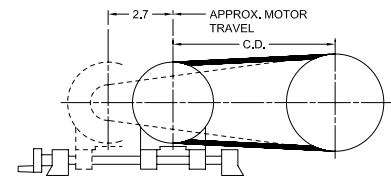

NEMA Motor Frame	Recommended Motor Bases
48, 56	48 / 56, 135, 200
	SMB - 143
56, 143T	SMB - 143
	145 / 60

VSD

160 / 160-HD Belt Selection Chart

PD Driven Sheave in	Minimum Center Distance by Selected Sheave Size "A" Belt Size ¹													
	A26 (27.3)	A31 (32.3)	A33 (34.3)	A35 (36.3)	A38 (39.3)	A42 (43.3)	A46 (47.3)	A48 (49.3)	A51 (52.3)	A53 (54.3)	A55 (56.3)	A60 (61.3)	A62 (63.3)	
	in	in	in	in	in	in	in	in	in	in	in	in	in	
4.0	5.9	8.4	9.4	10.5	12.0	14.0	16.0	17.0	18.5	19.5	20.5	23.0	24.0	
5.0	—	7.7	8.7	9.7	11.2	13.2	15.2	16.2	17.7	18.7	19.7	22.2	23.2	
6.0	—	—	7.9	8.9	10.4	12.4	14.4	15.4	16.9	17.9	18.9	21.4	22.4	
8.0	—	—	—	—	8.8	10.8	12.8	13.8	15.3	16.3	17.3	19.8	20.8	
10.0	—	—	—	—	—	9.1	11.1	12.1	13.6	14.6	15.6	18.1	19.1	
12.0	—	—	—	—	—	—	—	10.3	11.8	12.8	13.9	16.4	17.4	

Note: ■ 1 indicates: These are nominal belt sizes. The number in parentheses is the actual pitch length.



Variable Speed Drives

Aluminoline Models 170, 175 and 180

Item Selection

Aluminoline Series

Two-Side Moveable
Adjustable Center Drives
1/2 through 1-1/2 HP
"A" & "B" Belt
Ratio 2.7:1

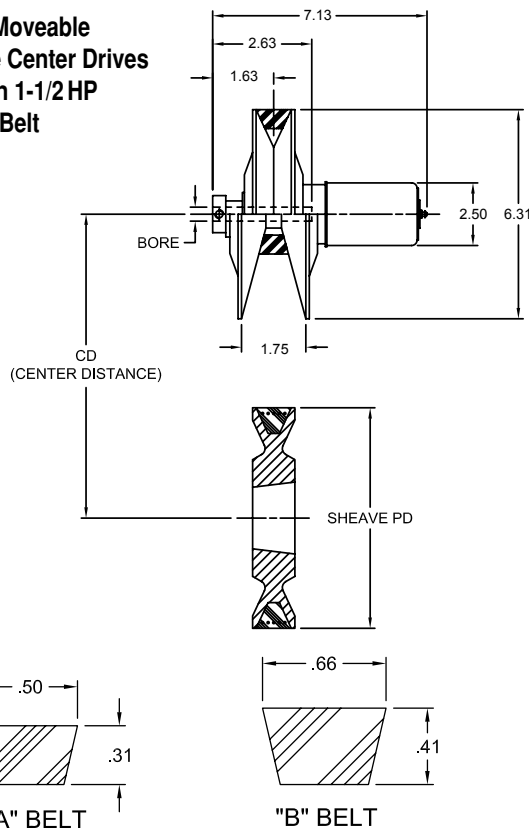

Model 170 Spring-Loaded Driver Pulley

UPC Number	Bore in	PD		Belt Series	Torque Capacity in-lb	HP Rating	
		Min in	Max in			1750 RPM	1150 RPM
18617	5/8	2.24	6.06	A	27	3/4	1/2
18618	3/4	2.24	6.06	A			
18619	7/8	2.34	5.96	B			

Model 175 Spring-Loaded Driver Pulley

UPC Number	Bore in	PD		Belt Series	Torque Capacity in-lb	HP Rating	
		Min in	Max in			1750 RPM	1150 RPM
18645	5/8	2.24	6.06	A	36	1	3/4
18646	3/4	2.24	6.06	A			
18647	7/8	2.34	5.96	B			

Model 180 Spring-Loaded Driver Pulley

UPC Number	Bore in	PD		Belt Series	Torque Capacity in-lb	HP Rating	
		Min in	Max in			1750 RPM	1150 RPM
18675	5/8	2.24	6.06	A	54	1-1/2	1
18676	3/4	2.24	6.06	A			
18677	7/8	2.34	5.96	B			

Horsepower Curves - 1,750 RPM Input

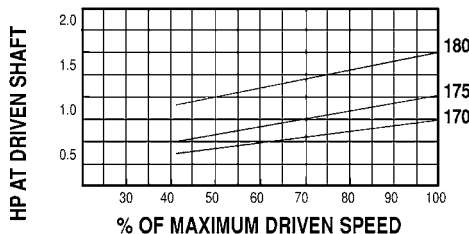

170 / 175 / 180 Driven Sheave Selection Table

PD Driven Sheave in	Driven Speed Range				Driven Torque		
	1750 RPM Motor		1150 RPM Motor		170	175	180
	Min RPM	Max RPM	Min RPM	Max RPM	in-lb	in-lb	in-lb
4.0	1,025	2,605	675	1710	19	24	35
5.0	820	2,085	535	1370	24	30	45
6.0	685	1,735	450	1140	28	36	54
8.0	515	1,300	340	855	38	48	72
10.0	410	1,040	270	685	48	60	90
12.0	345	865	225	570	56	75	112

Note: ■ Using an "A" section belt with the 170 / 175 / 180 series will actually increase the driven speed range. The maximum driven speed will be slightly higher and the minimum speed will be slightly lower.

170 / 175 / 180 Belt Selection

PD Driven Sheave in	Minimum Center Distance by Selected Sheave Size "B" Belt Size'											
	B31 (32.8) in	B33 (34.8) in	B35 (36.8) in	B38 (39.8) in	B42 (43.8) in	B46 (47.8) in	B48 (49.8) in	B51 (52.8) in	B53 (54.8) in	B55 (56.8) in	B60 (61.8) in	B62 (63.8) in
4.0	8.5	9.5	10.5	12.0	14.0	16.0	17.0	18.5	19.5	20.5	23.0	24.0
5.0	—	8.8	9.8	11.3	13.3	15.3	16.3	17.8	18.8	19.8	22.3	23.3
6.0	—	—	9.0	10.5	12.5	14.5	15.5	17.0	18.0	19.0	21.5	22.5
8.0	—	—	—	8.9	10.9	12.9	13.9	15.4	16.4	17.4	19.9	20.9
10.0	—	—	—	—	9.2	11.2	12.2	13.7	14.7	15.7	18.2	19.2
12.0	—	—	—	—	—	—	10.4	11.9	13.0	14.0	16.5	17.5

Note: ■ 1 indicates: These are nominal belt sizes. The number in parentheses is the actual pitch length.

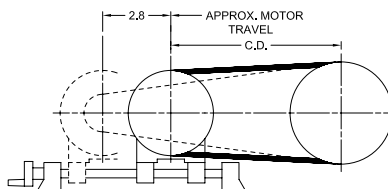

NEMA Motor Frame	Recommended Motor Bases
48, 56	48 / 56, 135, 200
143T	SMB - 143, 145 / 60
145T	SMB - 184, 301

Wide Variable Speed Belts

1/3 through 15 HP

Pulleys in the WB series use wide variable speed belts for the most efficient transmission of torque through the widest possible speed range. These pulleys are two-side moveable for the best possible belt alignment when used with a grooved companion sheave. However, the location of the belt centerline close to the bore end of the pulley reduces the overhung load on motor bearings and seals. Precision-calibrated springs maintain correct pressure, keeping the belt properly tensioned and minimizing belt slip.

WB pulleys can be used on both adjustable and fixed center drives. They offer maximum service when lubricated through a convenient grease fitting and occasionally run through the speed range.

Features

- Sizes range from 6 to 13 inches in diameter
- Ratings to 15 HP
- Made of durable cast iron flanges (if greater than 1 HP)
- Lightweight, corrosion-resistant anodized aluminum flanges on Models 245 and 260
- Precision balanced for smooth operation

Belt Selection

WB pulleys offer optimum speed ratios because they are used with wide variable speed belts. Pulley flanges are designed to match standard belt angle and width, so each pulley model must be matched to the correct belt to insure full speed range and maximum torque capacity.

Adjustable Center Drives

The typical adjustable center drive consists of: the WB pulley mounted on the motor shaft; a grooved companion sheave mounted with a bushing on the driven shaft; an adjustable motor base; and a variable speed belt. A wide range of pulley sizes and horsepower ratings are available from the WB series to fit the system requirements, and Lovejoy offers the correct drive belt, companion sheave, bushing, and motor base to complete the package.

Fixed Center Drives

Fixed center, or compound, drives offer greater driven speed ranges in a compact space. A fixed center drive consisting of a WB spring-loaded pulley and an adjustable pulley to match offers the best possible package for "C" mount configurations where zero offset is critical. Zero offset means that the driver and driven units are in line with one another, and the driven pulley is mounted in such a way that the belt rides as close as possible to the driven unit. This reduces overhung load and provides a smoother running drive. Three WB fixed center drive packages are available, from 1/3 through 3 HP.



WB Series Pulley



Typical Adjustable Center Drive



Typical Fixed Center Drive



Variable Speed Drives

WB Models 245, 260 and 260-HD

Item Selection

WB Series

Two-Side Moveable
Adjustable Center Distance
1/3 through 1 HP
1422V Belts
Ratio 3 to 1

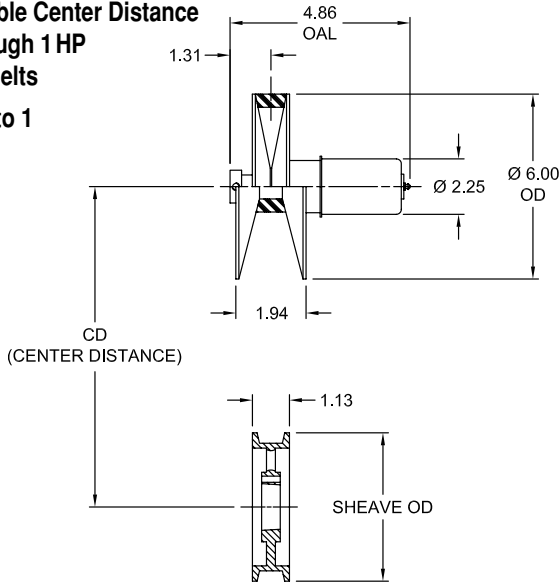

Model 245 Spring-Loaded Driver Pulley

UPC Number	Bore in	PD		Torque Capacity in-lb	HP Rating	
		Min in	Max in		1750 RPM	1150 RPM
18698	1/2	1.90	5.80	18	1/2	1/3
18700	5/8				1/2	1/3
18702	3/4				1/2	1/3

Model 260 Spring-Loaded Driver Pulley

UPC Number	Bore in	PD		Torque Capacity in-lb	HP Rating	
		Min in	Max in		1750 RPM	1150 RPM
18721	1/2	1.90	5.80	27	3/4	1/2
18724	5/8				3/4	1/2
18726	3/4				3/4	1/2

Model 260HD Spring-Loaded Driver Pulley

UPC Number	Bore in	PD		Torque Capacity in-lb	HP Rating	
		Min in	Max in		1750 RPM	1150 RPM
42116	1/2	1.90	5.80	36	1	3/4
18756	5/8				1	3/4
18757	3/4				1	3/4

245 / 260 / 260HD Driven Sheave Selection Table

Grooved Driven Sheave				Driven Speed Range				Driven Torque		
UPC Number	Model	PD in	OD in	1750 RPM Motor		1150 RPM Motor		245 in-lb	260 in-lb	260-HD in-lb
				Min RPM	Max RPM	Min RPM	Max RPM			
19493	1422G5.5SH	5.3	5.5	630	1,915	415	1,255	16	25	33
19495	1422G6SH	5.8	6.0	575	1,750	380	1,150	18	27	36
19497	1422G7SH	6.8	7.0	490	1,490	325	980	21	32	42
19499	1422G8SH	7.8	8.0	430	1,300	280	855	24	36	48
19501	1422G9SH	8.8	9.0	380	1,150	250	755	27	41	55
19503	1422G10SH	9.8	10.0	340	1,035	225	680	30	46	61
19507	1422G11SH	10.8	11.0	310	935	205	615	34	50	67
19509	1422G12SH	11.8	12.0	285	860	185	565	37	55	73
19511	1422G14SH	13.8	14.0	245	735	160	480	43	64	86

Horsepower Curves – 1,750 RPM Input

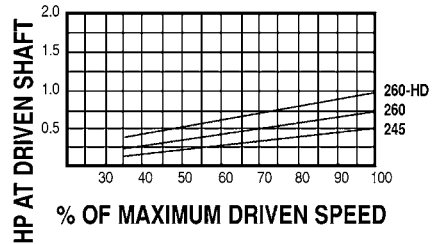

245 / 260 / 260HD Belt Selection Table

UPC Number	Belt Size	Center Distance by Selected Sheave Size						
		1422G-5.5SH in	1422G-6SH in	1422G-7SH in	1422G-8SH in	1422G-9SH in	1422G-10SH in	1422G-11SH in
23255	1422V300	6.3	—	—	—	—	—	—
23257	1422V340	8.3	7.9	7.1	—	—	—	—
23258	1422V360	9.3	8.9	8.1	7.3	—	—	—
23259	1422V400	11.3	10.9	10.1	9.3	8.4	—	—
23260	1422V420	12.3	11.9	11.1	10.3	9.4	8.6	—
23261	1422V460	14.3	13.9	13.1	12.3	11.4	10.6	9.7
23262	1422V480	15.3	14.9	14.1	13.3	12.4	11.6	10.7
23263	1422V540	18.3	17.9	17.1	16.3	15.4	14.6	13.7
23264	1422V600	21.3	20.9	20.1	19.3	18.5	17.6	16.7
23265	1422V660	24.3	23.9	23.1	22.3	21.5	20.6	19.8
23266	1422V720	27.3	26.9	26.1	25.3	24.5	23.6	22.8
23267	1422V780	30.3	29.9	29.1	28.3	27.5	26.6	25.8

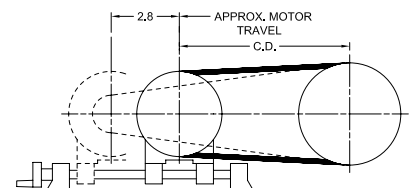
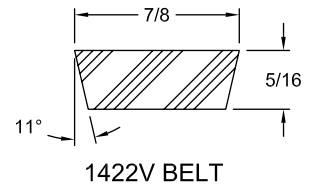

NEMA Motor Frame	Recommended Motor Bases
143T, 145T 185T, 184T	403 or SMB - 184

Note: ■ When referencing the Lovejoy UPC number in this table, include 685144 as a prefix to the number shown in the tables above.

VSD



Variable Speed Drives

WB Models 301E and 301E-HD

Item Selection

WB Series

Two-Side Moveable
Adjustable Center Distance
3/4 through 2 HP
1922V Belts
Ratio 3 to 1

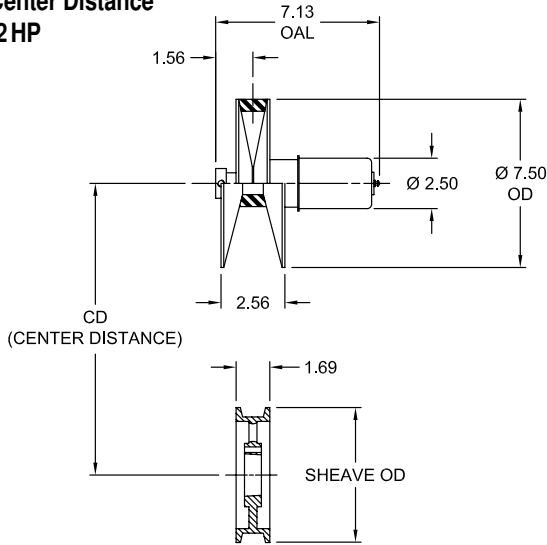

Model 301E Spring-Loaded Driver Pulley

UPC Number	Bore in	PD		Torque Capacity in-lb	HP Rating	
		Min in	Max in		1750 RPM	1150 RPM
18761	5/8	2.42	7.28	54	1 to 1-1/2	3/4 to 1
18763	3/4					
18764	7/8					
18767	1					

Model 301E-HD Spring-Loaded Driver Pulley

UPC Number	Bore in	PD		Torque Capacity in-lb	HP Rating	
		Min in	Max in		1750 RPM	1150 RPM
42367	5/8	2.42	7.28	72	2	1-1/2
42368	3/4					
42369	7/8					
42370	1					

301E / 301E-HD Driven Sheave Selection Table

Grooved Driven Sheave				Driven Speed Range				Driven Torque	
UPC Number	Model	PD in	OD in	1750 RPM Motor		1150 RPM Motor		301E	301E-HD
				Min RPM	Max RPM	Min RPM	Max RPM	in-lb	in-lb
19520	1922G7SK	6.78	7.0	625	1,875	410	1,230	50	67
19522	1922G8SK	7.78	8.0	545	1,635	360	1,075	58	77
19523	1922G9SK	8.78	9.0	485	1,450	320	950	65	87
19524	1922G10SK	9.78	10.0	435	1,300	285	855	73	97
19528	1922G12SK	11.78	12.0	360	1,080	240	710	87	117
19529	1922G14SK	13.78	14.0	310	920	205	605	102	136
19531	1922G16SK	15.78	16.0	270	805	180	530	117	156

Horsepower Curves – 1,750 RPM Input

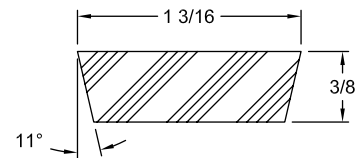
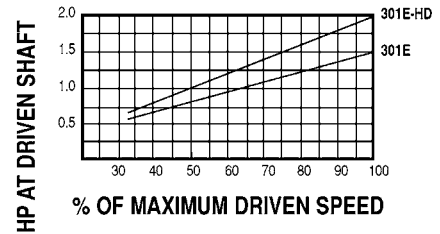

1922V BELT

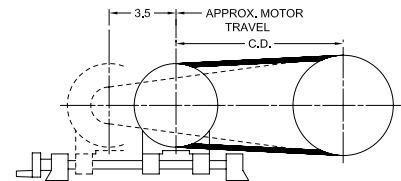

301E / 301E-HD Belt Selection Table

UPC Number	Belt Size	Center Distance by Selected Sheave Size							
		1922G-7SK in	1922G-8SK in	1922G-9SK in	1922G-10SK in	1922G-12SK in	1922G-14SK in	1922G-16SK in	
23282	1922Vt403	9.1	8.3	—	—	—	—	—	
23285	1922V443	11.1	10.3	9.5	—	—	—	—	
23287	1922V484	13.2	12.4	11.6	10.7	—	—	—	
23288	1922V526	15.3	14.5	13.7	12.8	11.1	—	—	
23290	1922V544	16.2	15.4	14.6	13.7	12.0	—	—	
23292	1922V604	19.2	18.4	17.6	16.7	15.1	13.3	—	
23293	1922V646	21.3	20.5	19.7	18.9	17.2	15.4	13.6	
23294	1922V666	22.3	21.5	20.7	19.9	18.2	16.4	14.6	
23295	1922V686	23.3	22.5	21.7	20.9	19.2	17.5	15.7	
23296	1922V706	24.3	23.5	22.7	21.9	20.2	18.5	16.7	
23298	1922V726	25.3	24.5	23.7	22.9	21.2	19.5	17.7	
23300	1922V806	29.3	28.5	27.7	26.9	25.2	23.5	21.7	
23303	1922V966	37.3	36.5	35.7	34.9	33.2	31.5	29.8	

Note: ■ When referencing the Lovejoy UPC number in this table, include 685144 as a prefix to the number shown in the tables above.

NEMA Motor Frame	Recommended Motor Bases
48, 56	48 / 56, 200, 135 SMB - 143
56, 143T	SMB - 143 145 / 60

VSD



Variable Speed Drives

WB Models 3030E and 303E-HD

Item Selection

WB Series

Two-Side Moveable
Adjustable Center Distance
2 through 4 HP
2322V Belts
Ratio 3 to 1

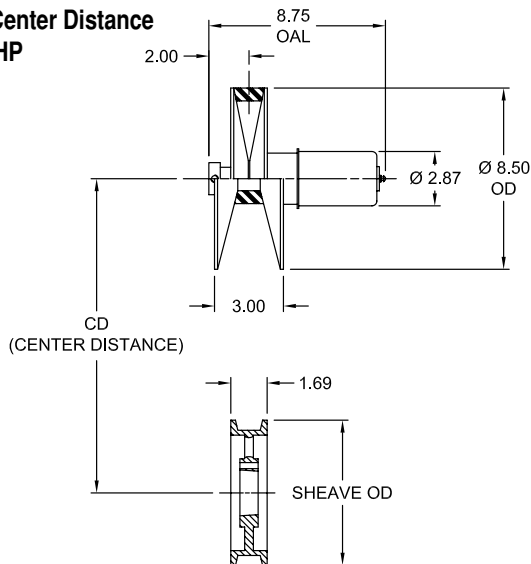

Model 3030E Spring-Loaded Driver Pulley

UPC Number	Bore in	PD		Torque Capacity in-lb	HP Rating	
		Min in	Max in		1750 RPM	1150 RPM
18937	7/8	2.70	8.25	108	3	2
18939	1					
18940	1-1/8					
27966	1-1/4					

Model 3030E-HD Spring-Loaded Driver Pulley

UPC Number	Bore in	PD		Torque Capacity in-lb	HP Rating	
		Min in	Max in		1750 RPM	1150 RPM
42377	7/8	2.70	8.25	144	4	3
18978	1					
72379	1-1/8					

3030E / 3030E-HD Driven Sheave Selection Table

Grooved Driven Sheave				Driven Speed Range				Driven Torque	
UPC Number	Model	PD in	OD in	1750 RPM Motor		1150 RPM Motor		3030E	3030E-HD
				Min RPM	Max RPM	Min RPM	Max RPM	in-lb	in-lb
19538	2322G7SK	6.75		700	2,135	460	1,405	88	118
19540	2322G8SK	7.75	8.0	610	1,860	405	1,220	101	135
15944	2322G9SK	8.75	9.0	540	1,650	355	1,080	115	152
19546	2322G10SK	9.75	10.0	485	1,480	320	970	128	170
19548	2322G12SK	11.75	12.0	405	1,225	265	805	157	205
19550	2322G14SK	13.75	14.0	345	1,050	230	690	180	240
19553	2322G16SK	15.75	16.0	300	915	200	600	206	275

Horsepower Curves – 1,750 RPM Input

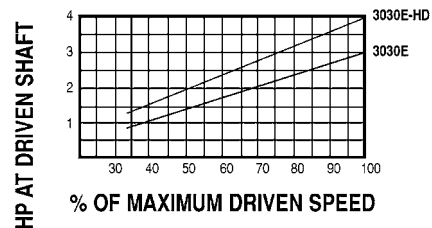

3030E / 3030E-HD Belt Selection Table

UPC Number	Belt Size	Center Distance by Selected Sheave Size						
		2322G-7SK in	2322G-8SK in	2322G-9SK in	2322G-10SK in	2322G-12SK in	2322G-14SK in	2322G-16SK in
23318	2322V481	12.2	11.5	10.7	9.9	—	—	—
23319	2322V521	14.2	13.5	12.7	11.9	—	—	—
23320	2322V541	15.2	14.5	13.7	12.9	11.2	—	—
23322	2322V601	18.2	17.5	16.7	15.9	14.2	12.5	—
23324	2322V621	19.3	18.5	17.7	16.9	15.2	13.5	—
23326	2322V661	21.3	20.5	19.7	18.9	17.2	15.5	13.8
23327	2322V681	22.3	21.5	20.7	19.9	18.3	16.5	14.8
23328	2322V701	23.3	22.5	21.7	20.9	19.3	17.6	15.8
23329	2322V721	24.3	23.5	22.7	21.9	20.3	18.6	16.8
23330	2322V801	28.3	27.5	26.7	25.9	24.3	22.6	20.8
23331	2322V826	29.5	28.7	28.0	27.1	25.5	23.8	22.1
23333	2322V886	32.5	31.7	31.0	30.2	28.5	26.8	25.1
23335	2322V1001	38.3	37.5	36.7	35.9	34.3	32.6	30.9
23337	2322V1271	51.8	51.0	50.2	49.4	47.8	46.2	44.5

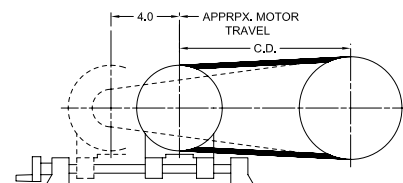
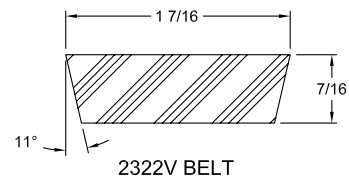

NEMA Motor Frame	Recommended Motor Bases
143T, 145T	SMB - 184 or 302-3
182T, 184T	

Note: ■ When referencing the Lovejoy UPC number in this table, include 685144 as a prefix to the number shown in the tables above.



Variable Speed Drives

WB Models 3030E and 303E-HD

Item Selection

WB Series

Two-Side Moveable
Adjustable Center Distance
2 through 4 HP
2926V Belts
Ratio 3.4 to 1

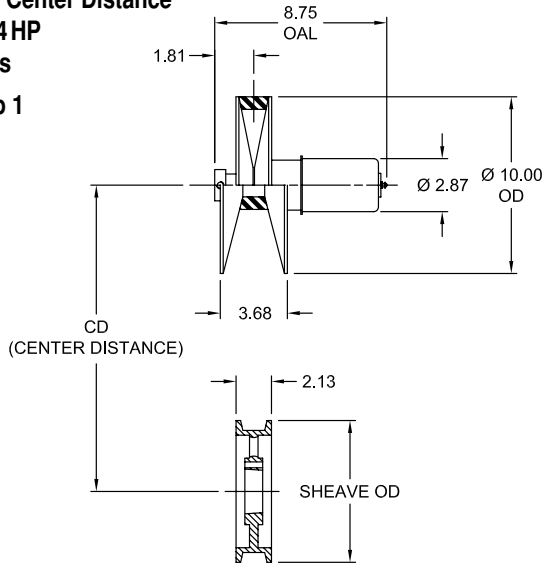

Model 303E Spring-Loaded Driver Pulley

UPC Number	Bore in	PD		Torque Capacity in-lb	HP Rating	
		Min in	Max in		1750 RPM	1150 RPM
18814	7/8	2.80	9.70	108	3	2
18817	1					
18819	1-1/8					
18820	1-1/4					

Model 303E-HD Spring-Loaded Driver Pulley

UPC Number	Bore in	PD		Torque Capacity in-lb	HP Rating	
		Min in	Max in		1750 RPM	1150 RPM
18856	1-1/8	2.80	9.70	144	4	3
43435	1-1/4					

303E / 303E-HD Driven Sheave Selection Table

Grooved Driven Sheave		Driven Speed Range				Driven Torque			
UPC Number	Model	PD in	OD in	1750 RPM Motor		1150 RPM Motor		303E in-lb	303E-HD in-lb
				Min RPM	Max RPM	Min RPM	Max RPM		
19561	2926G7SK	7.7	8.0	640	2,200	420	1,445	86	114
19563	2926G8SK	8.7	9.0	565	1,950	370	1,280	97	129
19565	2926G9SK	9.7	10.0	505	1,750	335	1,150	108	144
19567	2926G10SK	11.7	12.0	420	1,450	280	950	130	174
19569	2926G12SK	13.7	14.0	360	1,235	235	810	153	203
19572	2926G14SK	15.7	16.0	315	1,080	205	710	175	233
19575	2926G16SK	17.7	18.0	280	955	185	630	197	263

303E / 303E-HD Belt Selection Table

UPC Number	Belt Size	Center Distance by Selected Sheave Size						
		2926G-7SK in	2926G-8SK in	2926G-9SK in	2926G-10SK in	2926G-12SK in	2926G-14SK in	2926G-16SK in
23350	2926V486	10.6	9.8	—	—	—	—	—
23353	2926V546	13.6	12.8	12.1	—	—	—	—
23357	2926V606	16.6	15.8	15.1	13.5	—	—	—
23360	2926V646	18.6	17.8	17.1	15.5	13.8	—	—
23361	2926V666	19.6	18.8	18.1	16.5	14.8	13.1	—
23362	2926V686	20.6	19.8	19.1	17.5	15.8	14.1	—
23364	2926V726	22.6	21.8	21.1	19.5	17.8	16.1	14.3
23367	2926V786	25.6	24.8	24.1	22.5	20.8	19.1	17.4
23369	2926V856	29.1	28.3	27.6	26.0	24.3	22.6	20.9
23371	2926V906	31.6	30.8	30.1	28.5	26.8	25.2	23.4
23372	2926V966	34.6	33.8	33.1	31.5	29.8	28.2	26.4
23375	2926V1086	40.6	39.8	39.1	37.5	35.8	34.2	32.5
23376	2926V1146	43.6	42.8	42.1	40.5	38.9	37.2	35.5

Note: ■ When referencing the Lovejoy UPC number in this table, include 685144 as a prefix to the number shown in the tables above.

Horsepower Curves – 1,750 RPM Input

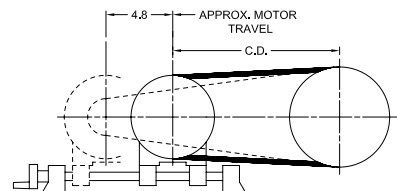
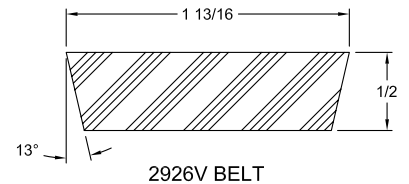
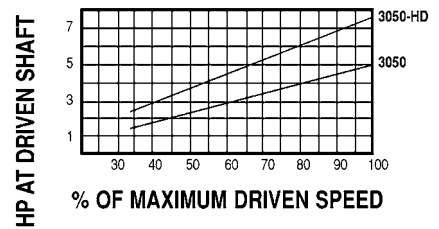

NEMA Motor Frame	Recommended Motor Bases
143T, 145T	302-3 or
185T, 184T	SMB - 184

VSD

WB Series

Two-Side Moveable
Adjustable Center Distance
3/4 through 3 HP
2926V Belts
Ratio 3.8 to 1

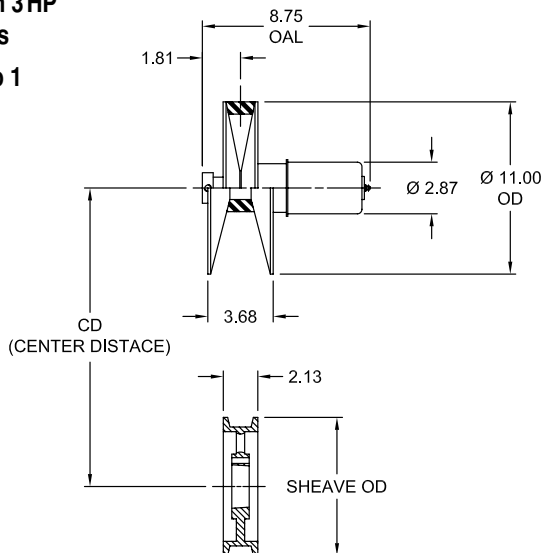

Model 401E Spring-Loaded Driver Pulley

UPC Number	Bore in	PD		Torque Capacity in-lb	HP Rating	
		Min in	Max in		1750 RPM	1150 RPM
18858	7/8	2.80	10.70	54	1 to 1-1/2	3/4 to 1
27802	1					
18859	1-1/8					

Model 402E Spring-Loaded Driver Pulley

UPC Number	Bore in	PD		Torque Capacity in-lb	HP Rating	
		Min in	Max in		1750 RPM	1150 RPM
18884	7/8	2.80	10.70	72	2	1-1/2
27803	1					
18885	1-1/8					

Model 403E Spring-Loaded Driver Pulley

UPC Number	Bore in	PD		Torque Capacity in-lb	HP Rating	
		Min in	Max in		1750 RPM	1150 RPM
18894	7/8	2.80	10.70	108	3	2
18896	1					
18897	1-1/8					
18898	1-1/4					

401E / 402E / 403E Driven Sheave Selection Table

Grooved Driven Sheave				Driven Speed Range				Driven Torque		
UPC Number	Model	PD in	OD in	1750 RPM Motor		1150 RPM Motor		401E	402E	403E
				Min RPM	Max RPM	Min RPM	Max RPM	in-lb	in-lb	in-lb
19561	2926G8SK	7.7	8.0	340	2,430	420	1,595	39	52	78
19563	2926G9SK	8.7	9.0	565	2,150	370	1,410	44	59	88
19565	2926G10SK	9.7	10.0	505	1,930	335	1,265	49	65	98
19567	2926G12SK	11.7	12.0	420	1,600	280	1,050	59	79	118
19569	2926G14SK	13.7	14.0	360	1,365	235	895	69	92	138
19572	2926G16SK	15.7	16.0	315	1,190	205	780	79	106	158
19575	2926G18SK	17.7	18.0	280	1,055	185	695	89	119	179

Horsepower Curves – 1,750 RPM Input

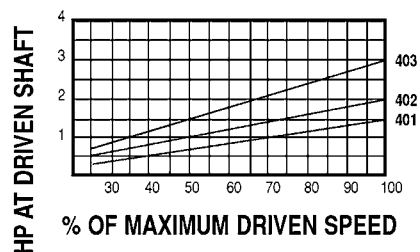

401E / 402E / 403E Belt Selection Table

UPC Number	Belt Size	Center Distance by Selected Sheave Size						
		2926G-8SK in	2926G-9SK in	2926G-10SK in	2926G-12SK in	2926G-14SK in	2926G-16SK in	2926G-18SK in
23350	2926V486	10.0	—	—	—	—	—	—
23353	2926V546	13.0	12.3	11.5	—	—	—	—
23357	2926V606	16.0	15.3	14.5	12.9	—	—	—
53360	2926V646	18.0	17.3	16.5	14.9	13.3	—	—
23661	2926V666	19.0	18.3	17.5	15.9	14.3	—	—
23362	2926V686	20.0	19.3	18.5	16.9	15.3	13.6	—
23364	2926V726	22.0	21.3	20.5	18.9	17.3	15.6	—
23367	2926V786	25.0	24.3	23.5	21.9	20.3	18.6	16.9
23369	2926V856	28.1	27.8	27.0	25.4	23.8	22.1	20.4
23371	2926V906	31.0	30.3	29.5	27.9	26.3	24.6	22.9
23372	2926V966	34.0	33.3	32.5	30.9	29.3	27.7	26.0
23375	2926V1086	40.0	39.3	38.5	36.9	35.3	33.7	32.0
23376	2926V1146	43.0	42.3	41.5	39.9	38.3	36.7	35.0

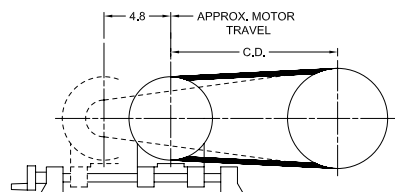
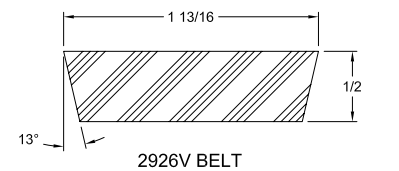

NEMA Motor Frame	Recommended Motor Bases
143T, 145T	403 or
185T, 184T	SMB - 184

Note: ■ When referencing the Lovejoy UPC number in this table, include 685144 as a prefix to the number shown in the tables above.



Variable Speed Drives

WB Models 3050E and 3050E-HD

Item Selection

WB Series

Two-Side Moveable
Adjustable Center Distance
3 through 7-1/2 HP
2926V Belts
Ratio 3 to 1

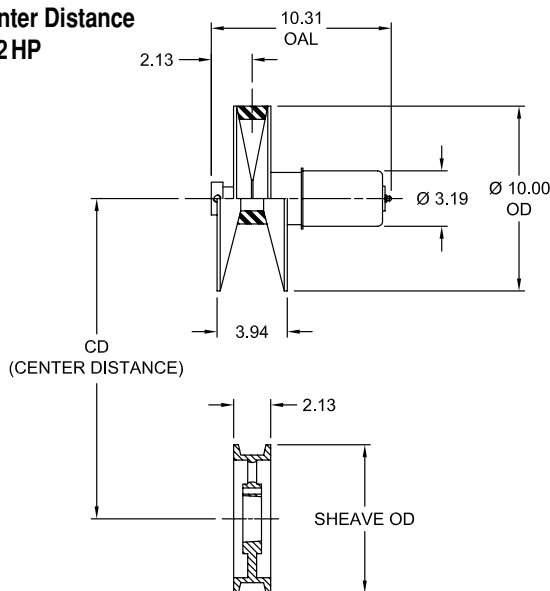

Model 3050E Spring-Loaded Driver Pulley

UPC Number	Bore in	PD		Torque Capacity in-lb	HP Rating	
		Min in	Max in		1750 RPM	1150 RPM
18988	1-1/8	3.20	9.70	180	5	3
18989	1-1/4					
18990	1-3/4					

Model 3050E-HD Spring-Loaded Driver Pulley

UPC Number	Bore in	PD		Torque Capacity in-lb	HP Rating	
		Min in	Max in		1750 RPM	1150 RPM
43184	1-1/8	3.20	9.70	270	7-1/2	5
19031	1-3/8					

3050E / 3050E-HD Driven Sheave Selection Table

Grooved Driven Sheave				Driven Speed Range				Driven Torque	
UPC Number	Model	PD in	OD in	1750 RPM Motor		1150 RPM Motor		3050E	3050E-HD
				Min RPM	Max RPM	Min RPM	Max RPM	in-lb	in-lb
19561	2926G8SK	7.7	8.0	730	2,200	480	1,445	143	214
19563	2926G9SK	8.7	9.0	645	1,950	425	1,280	161	242
19565	2926G10SK	9.7	10.0	580	1,750	380	1,150	180	270
19567	2926G12SK	11.7	12.0	480	1,450	315	950	217	326
19569	2926G14SK	13.7	14.0	410	1,235	270	810	254	381
19572	2926G16SK	15.7	16.0	360	1,080	235	710	291	437
19575	2926G18SK	17.7	18.0	320	955	210	630	328	493

Horsepower Curves – 1,750 RPM Input

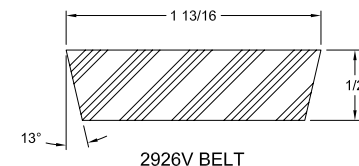
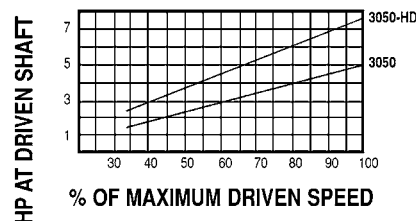

3050E / 3050E-HD Belt Selection Table

UPC Number	Belt Size	Center Distance by Selected Sheave Size							
		2926G-8SK in	2926G-9SK in	2926G-10SK in	2926G-12SK in	2926G-14SK in	2926G-16SK in	2926G-18SK in	
23350	2926V486	10.6	9.8	—	—	—	—	—	
23353	2926V546	13.6	12.8	12.1	—	—	—	—	
23357	2926V606	16.6	15.8	15.1	13.5	—	—	—	
53360	2926V646	18.6	17.8	17.1	15.5	13.8	—	—	
23661	2926V666	19.6	18.8	18.1	16.5	14.8	13.1	—	
23362	2926V686	20.6	19.8	19.1	17.5	15.8	14.1	—	
23364	2926V726	22.6	21.8	21.1	19.5	17.8	16.1	14.3	
23367	2926V786	25.6	24.8	24.1	22.5	20.8	19.1	17.4	
23369	2926V856	29.1	28.3	27.6	26.0	24.3	22.6	20.9	
23371	2926V906	31.6	30.8	30.1	28.5	26.8	25.2	23.4	
23372	2926V966	34.6	33.8	33.1	31.5	29.8	28.2	26.4	
23375	2926V1086	40.6	39.8	39.1	37.5	35.8	34.2	32.5	
23376	2926V1146	43.6	42.8	42.1	40.5	38.9	37.2	35.5	

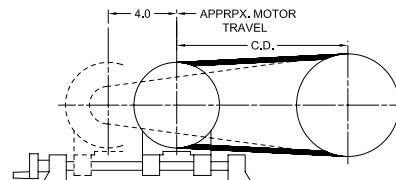

NEMA Motor Frame	Recommended Motor Bases
184T, 213T	305-8 or
215T, 254T	SMB - 254

Note: ■ When referencing the Lovejoy UPC number in this table, include 685144 as a prefix to the number shown in the tables above.



Variable Speed Drives

WB Models 3075B, 3100B and 3150B

Item Selection

WB Series

Two-Side Moveable
Adjustable Center Distance
5 through 15 HP
4430V Belts
Ratio 3 to 1

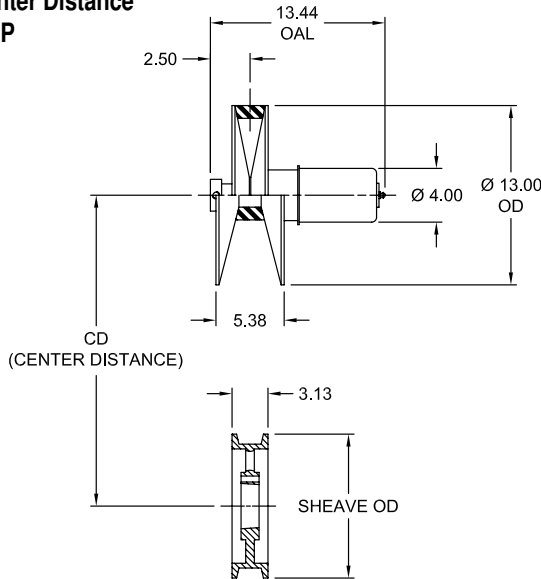

Model 3075B Spring-Loaded Driver Pulley

UPC Number	Bore in	PD		Torque Capacity in-lb	HP Rating	
		Min in	Max in		1750 RPM	1150 RPM
53008	1-1/8	4.25	12.60	270	7-1/2	5
53009	1-1/4					
53010	1-3/8					
53011	1-5/8					

Model 3100B Spring-Loaded Driver Pulley

UPC Number	Bore in	PD		Torque Capacity in-lb	HP Rating	
		Min in	Max in		1750 RPM	1150 RPM
53012	1-1/4	4.25	12.60	360	10	7-1/2
53013	1-3/8					
53003	1-5/8					

Model 3150B Spring-Loaded Driver Pulley

UPC Number	Bore in	PD		Torque Capacity in-lb	HP Rating	
		Min in	Max in		1750 RPM	1150 RPM
53015	1-1/4	4.25	12.60	540	15	10
53016	1-3/8					
53017	1-5/8					

3075B / 3100B / 3150B Driven Sheave Selection Table

Grooved Driven Sheave				Driven Speed Range				Driven Torque		
UPC Number	Model	PD in	OD in	1750 RPM Motor		1150 RPM Motor		3075B	3100B	3150B
				Min RPM	Max RPM	Min RPM	Max RPM	in-lb	in-lb	in-lb
19600	4430G10.4SF	10.0	10.4	745	2,205	490	1,145	215	285	730
19604	4430G12SK	11.6	12.0	645	1,900	425	1,245	249	330	498
19607	4430G14SK	13.6	14.0	550	1,620	360	1,065	292	388	584
19610	4430G16SK	15.6	16.0	480	1,410	315	925	335	445	670
19614	4430G18.4SF	18.0	18.4	415	1,225	275	800	387	516	774
19616	4430G20.4SF	20.0	20.4	375	1,100	245	720	430	570	860
19618	4430G24.4SF	24.0	24.4	310	915	205	600	516	684	1032

Horsepower Curves 1,750 RPM Input

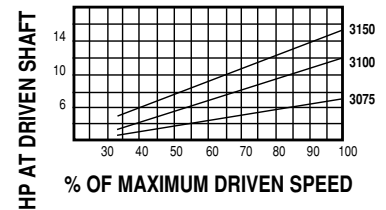

3075B / 3100B / 3150B Belt Selection Table

UPC Number	Belt Size	Center Distance by Selected Sheave Size						
		4430G-10.4SF in	4430G-12SK in	4430G-14SK in	4430G-16SK in	4430G-18.4SF in	4430G-20.4SF in	4430G-24.4SF in
23397	4430V555	—	—	—	—	—	—	—
23400	4430V600	12.7	—	—	—	—	—	—
23403	4430V660	15.2	14.0	—	—	—	—	—
23407	4430V718	18.1	16.9	15.3	—	—	—	—
23411	4430V760	20.2	19.0	17.4	15.8	—	—	—
23413	4430V790	21.7	20.5	18.9	17.3	15.3	—	—
23414	4430V850	24.7	23.5	21.9	20.3	18.3	—	—
23416	4430V910	27.7	26.5	24.9	23.3	21.3	19.6	—
23418	4430V970	30.7	29.5	27.9	26.3	24.3	22.6	19.1
23421	4430V1030	33.7	32.5	30.9	29.3	27.3	25.6	22.1
23423	4430V1090	36.7	35.5	33.9	32.3	30.3	28.6	25.2
23426	4430V1150	39.7	38.5	36.9	35.3	33.3	31.7	28.2
23430	4430V1320	48.2	47.0	45.4	43.8	41.9	40.2	36.8
23434	4430V1610	62.7	61.5	59.9	58.3	56.4	54.7	51.4

Note: ■ When referencing the Lovejoy UPC number in this table, include 685144 as a prefix to the number shown in the tables above.

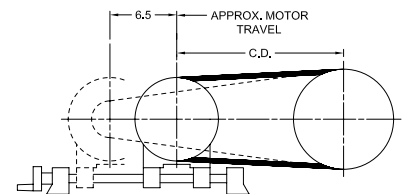
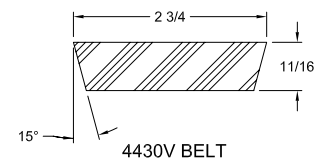

NEMA Motor Frame	Recommended Motor Bases
184T, 213T	SMB - 254 or 305-8
215T, 254T	310-30
215T, 254T, 256T, 284T, 286T, 324T	310-30



Variable Speed Drives

WB Models M-007, 245 and 260

Item Selection

WB Series

Fixed Center Distance
1/3 through 3/4 HP
1422V Belts
Ratio 9.3 to 1

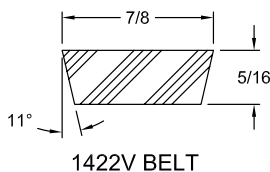
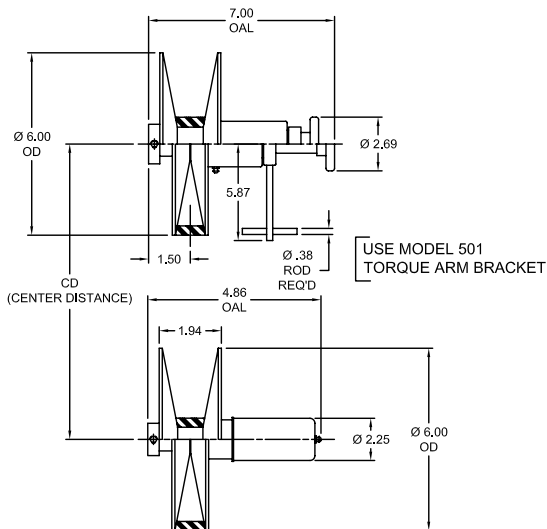

Model M-007 Adjustable Driver Pulley

UPC Number	Bore in	PD		HP Rating	
		Min in	Max in	1750 RPM	1150 RPM
31670	1/2	1.90	5.80	1/2 to 3/4	1/3 to 1/2
31671	5/8				
31672	3/4				

Model 245 Spring-Loaded Driven Pulley

UPC Number	Bore in	PD		HP Rating	
		Min in	Max in	1750 RPM	1150 RPM
18698	1/2	1.90	5.80	1/2	1/3
18700	5/8				
18702	3/4				

Model 260 Spring-Loaded Driven Pulley

UPC Number	Bore in	PD		HP Rating	
		Min in	Max in	1750 RPM	1150 RPM
18721	1/2	1.90	5.80	3/4	1/2
18724	5/8				
18726	3/4				

Note: ■ Because both the M-007 and the 245/260 are 2-side moveable pulleys, the above UPC numbers apply for both "C" Mount and "Z" Mount drives.

Horsepower Curves – 1,750 RPM Input

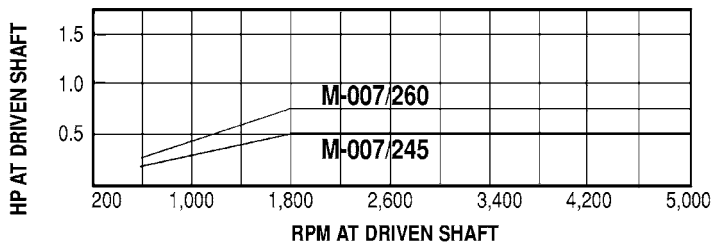

M-007 / 245 / 260 Belt Selection Chart

Center Distance & Belt Size			Driven Speed Range					
			1750 RPM Driver			1150 RPM Driver		
UPC Number	Belt Size	CD in	Min RPM	Max RPM	Ratio	Min RPM	Max RPM	Ratio
23255	1422V300	8.70	573	5,342	9.3 to 1	377	3,510	9.3 to 1
23257	1422V340	10.73						
23258	1422V360	11.74						
23259	1422V400	13.76	573	5,342	9.3 to 1	377	3,510	9.3 to 1
23260	1422V420	14.77						
23261	1422V460	16.79						

Center Distance & Belt Size			Driven Speed Range					
			1750 RPM Driver			1150 RPM Driver		
UPC Number	Belt Size	CD in	Min RPM	Max RPM	Ratio	Min RPM	Max RPM	Ratio
23262	1422V480	17.79	573	5,342	9.3 to 1	377	3,510	9.3 to 1
23263	1422V540	20.81						
23264	1422V600	23.83						
23265	1422V660	26.84						
23266	1422V720	29.85						
23267	1422V780	32.85						

Notes: ■ The Driven Speed Range and the resulting Ratios given in this chart are derived from mathematical calculations based on exact center distances, constant motor speeds and manufacturers' belt specifications. Actual results will differ due to variations in any of these factors.
■ When referencing the Lovejoy UPC number in this table, include 685144 as a prefix to the number shown in the tables above.



Variable Speed Drives

WB Models M-1, 301C, and 301D

Item Selection

WB Series

Fixed Center Distance
3/4 through 1-1/2 HP
1922V Belts
Ratio 9.0 to 1

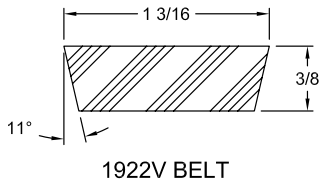
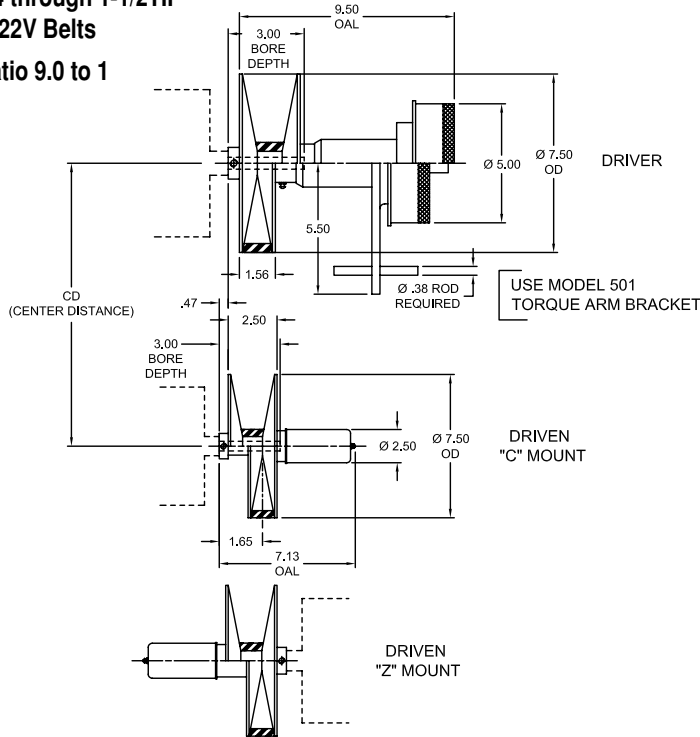

Model M-1 Adjustable Driver Pulley

UPC Number	Bore in	PD		HP Rating	
		Min in	Max in	1750 RPM	1150 RPM
20137	5/8	2.42	7.28	1 to 1-1/2	3/4 to 1
20138	3/4				
20139	7/8				
20141	1				

Note: ■ 17 turns of hand wheel required for full speed range.

Model 301C Spring-Loaded Driven Pulley ("C" Mount)

UPC Number	Bore in	PD		HP Rating	
		Min in	Max in	1750 RPM	1150 RPM
20371	5/8	2.42	7.28	1 to 1-1/2	3/4 to 1
20372	3/4				
20373	7/8				
20374	1				

Model 301D Spring-Loaded Driven Pulley ("Z" Mount)

UPC Number	Bore in	PD		HP Rating	
		Min in	Max in	1750 RPM	1150 RPM
42218	5/8	2.42	7.28	1 to 1-1/2	3/4 to 1
20376	3/4				
42219	7/8				
20378	1				

Horsepower Curves – 1750 RPM Input

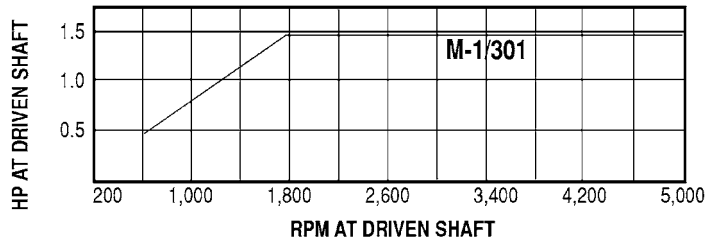

M-1 / 301C / 301D Belt Selection Table

Center Distance & Belt Size			Driven Speed Range					
			1750 RPM Driver			1150 RPM Driver		
UPC Number	Belt Size	CD in	Min RPM	Max RPM	Ratio	Min RPM	Max RPM	Ratio
23278	1922V321	8.06	582	5,264	9 to 1	383	3,459	9 to 1
23280	1922V363	10.21						
23281	1922V380	11.07						
23282	1922V403	12.24						
23283	1922V426	13.40	582	5,264	9 to 1	383	3,459	9 to 1
23285	1922V443	14.26						
23286	1922V454	14.82						
23287	1922V484	16.34						

Center Distance & Belt Size			Driven Speed Range					
			1750 RPM Driver			1150 RPM Driver		
UPC Number	Belt Size	CD in	Min RPM	Max RPM	Ratio	Min RPM	Max RPM	Ratio
23288	1922V526	18.46	582	5,264	9 to 1	383	3,459	9 to 1
23290	1922V544	19.36						
23292	1922V614	22.39						
23293	1922V646	24.50						
23294	1922V666	25.50						
23295	1922V686	26.51						
23296	1922V706	27.51	582	5,264	9 to 1	383	3,459	9 to 1
23298	1922V726	28.52						

Notes: ■ The Driven Speed Range and the resulting Ratios given in this chart are derived from mathematical calculations based on exact center distances, constant motor speeds and manufacturers' belt specifications. Actual results will differ due to variations in any of these factors.
■ When referencing the Lovejoy UPC number in this table, include 685144 as a prefix to the number shown in the tables above.



Variable Speed Drives

WB Models M-3, 3030C, and 3030D

Item Selection

WB Series

Fixed Center Distance
1-1/2 through 3 HP
2322V Belts
Ratio up to 9.3 to 1

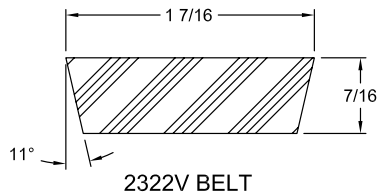
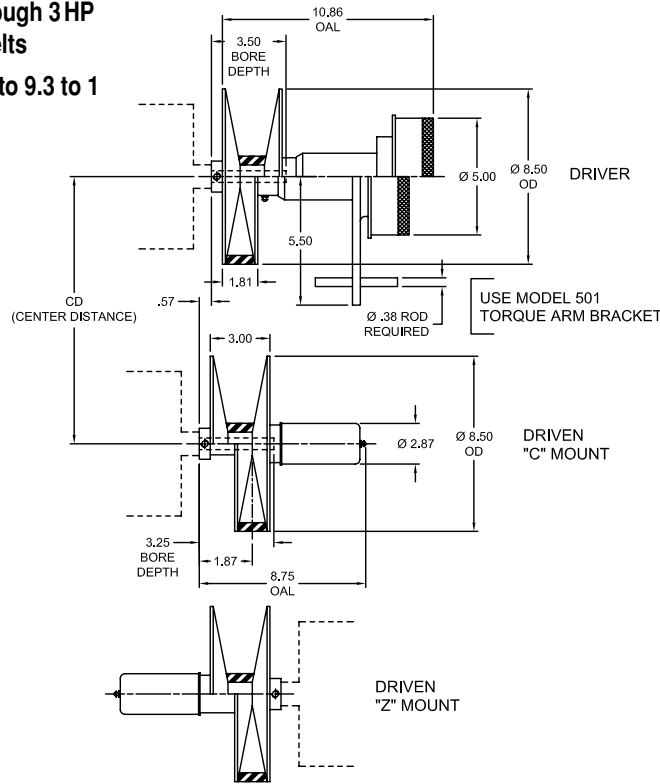

Model M-3 Adjustable Driver Pulley

UPC Number	Bore in	PD		HP Rating	
		Min in	Max in	1750 RPM	1150 RPM
20200	7/8	2.70	8.25	2 to 3	1-1/2 to 2
20201	1				
20202	1-1/8				

Note: ■ 22 turns of hand wheel required for full speed range.

Model 3030C Spring-Loaded Driven Pulley ("C" Mount)

UPC Number	Bore in	PD		HP Rating	
		Min in	Max in	1750 RPM	1150 RPM
20381	7/8	2.70	8.25	2 to 3	1-1/2 to 2
20382	1				
20383	1-1/8				

Model 3030D Spring-Loaded Driven Pulley ("Z" Mount)

UPC Number	Bore in	PD		HP Rating	
		Min in	Max in	1750 RPM	1150 RPM
20387	7/8	2.70	8.25	2 to 3	1-1/2 to 2
42902	1				
42903	1-1/8				

Horsepower Curves - 1,750 RPM Input

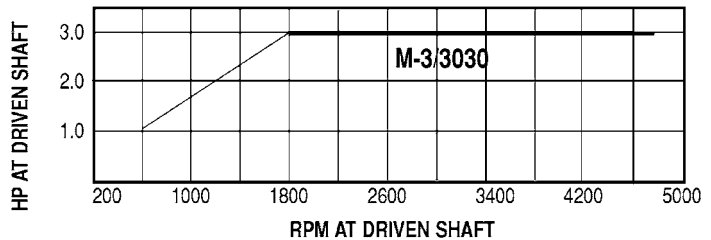

M-3 / 3030C / 3030D Belt Selection Table

Center Distance & Belt Size			Driven Speed Range					
			1750 RPM Driver			1150 RPM Driver		
UPC Number	Belt Size	CD in	Min RPM	Max RPM	Ratio	Min RPM	Max RPM	Ratio
23315	2322V421	12.08	573	4,720	8.2 to 1	377	3,513	9.3 to 1
23317	2322V441	13.10						
23318	2322V481	15.13						
23319	2322V521	17.15						
23320	2322V541	18.16						
23322	2322V601	21.19	573	4,720	8.2 to 1	377	3,513	9.3 to 1
23324	2322V621	22.20						
23326	2322V661	24.21						

Center Distance & Belt Size			Driven Speed Range					
			1750 RPM Driver			1150 RPM Driver		
UPC Number	Belt Size	CD in	Min RPM	Max RPM	Ratio	Min RPM	Max RPM	Ratio
23327	2322V681	25.22	573	4,720	8.2 to 1	377	3,513	9.3 to 1
23328	2322V701	26.23						
23329	2322V721	27.24						
23330	2322V801	31.26						
23331	2322V826	32.51						
23333	2322V886	35.53	573	4,720	8.2 to 1	377	3,513	9.3 to 1
23335	2322V1001	41.30						
23337	2322V1271	54.83						

Notes: ■ The Driven Speed Range and the resulting Ratios given in this chart are derived from mathematical calculations based on exact center distances, constant motor speeds and manufacturers' belt specifications. Actual results will differ due to variations in any of these factors.
■ When referencing the Lovejoy UPC number in this table, include 685144 as a prefix to the number shown in the tables above.

Fixed Center Drives

1/3 through 3 HP
 Wide Variable Speed Belts

In general, fixed center drives provide a greater total speed ratio than adjustable center drives. Traditional designs offer two pulleys of the same diameter, which means that a large portion of the driven speed range will be above motor speed. For those applications that require wide speed range and low driven speed, this has been a problem.

Lovejoy's new Hi-Ratio system solves this problem by mating smaller driver and larger driven pulleys to provide the unique combination of broader driven speed ranges and lower minimum driven speeds.

Features

- Precision-balanced cast iron flanges for durability
- No maintenance required, thanks to a unique self-lubricating bearing material used between sliding surfaces
- Driven pulley springs are calibrated to maintain correct flange pressure against the belt
- Minimum offset with the most common "C" mount configuration
- Compact drive package because the driver and driven units are nearly in line with one another
- Three drive packages available, ranging from 1/3 through 5 HP with a 1,750 RPM motor. Speed ratios up to 11.5:1 can be attained

A motorized control feature is available for all three drive packages, making it possible to convert from the standard handwheel to convenient remote control. This option consists of a servo motor that opens and closes the driver pulley flanges from a separate control station, allowing accurate speed adjustment in locations that may be inconvenient, remote or hazardous. Conversion is easy, requiring only the removal of the handwheel and torque rod from the standard manual pulley, installing the motorized torque arm in place of the handwheel, and connecting the CN2601 control switch to the servo motor and power source.

Every fixed center drive requires a torque arm bracket to prevent rotation of the handwheel so that it can be adjusted while the motor is running. Lovejoy offers a universally adaptable bracket, the Model 501.



Hi Ratio Series Pulley & Belt

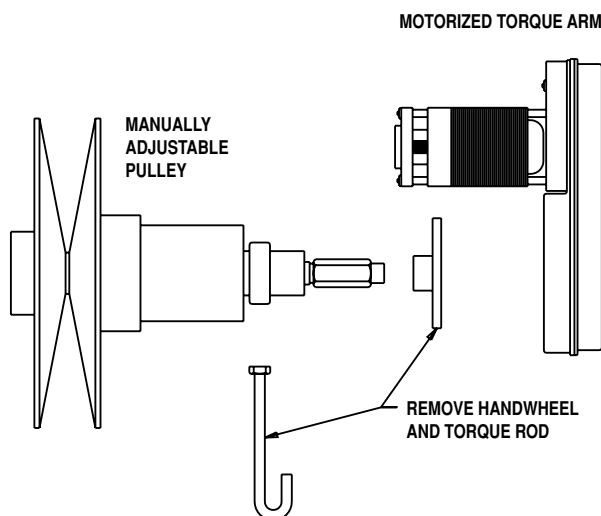



Variable Speed Drives

Hi-Ratio Models M-14 and 1401

Item Selection

Hi-Ratio Series

Fixed Center Distance
1/3 through 1 HP
1422V Belts
Ratio up to 8.4 to 1

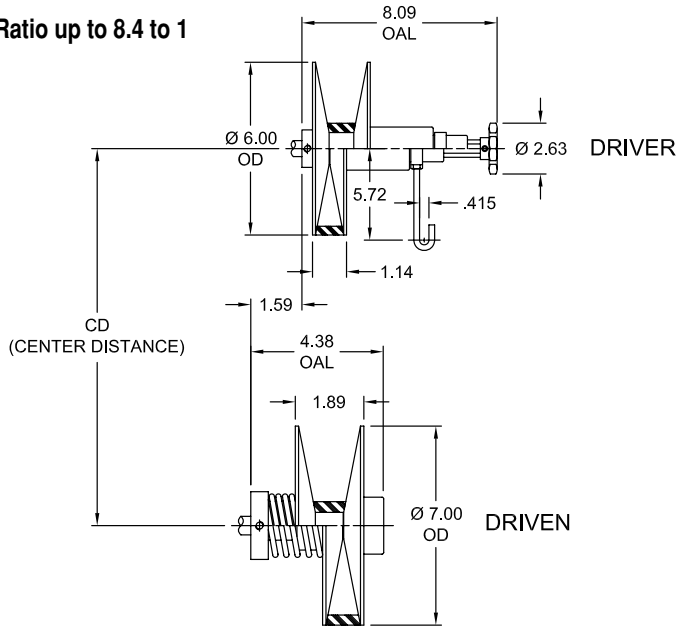

Model M-14 Adjustable Driver Pulley

UPC Number	Bore in	PD		HP Rating	
		Min in	Max in	1750 RPM	1150 RPM
43314	5/8	1.67	5.80	1/2 to 1	1/3 to 3/4
43315	3/4				
43316	7/8				

Note: ■ 17 turns of hand wheel required for full speed range.

Model 1401 Spring-Loaded Driven Pulley

UPC Number	Bore in	PD		HP Rating	
		Min in	Max in	1750 RPM	1150 RPM
43317	5/8	2.67	6.80	1/2 to 1	1/3 to 3/4
43318	3/4				
43319	7/8				
43320	1				

Notes: ■ The above UPC numbers are for "C" Mount drives only.
■ Consult the factory for "Z" mount or thru bore applications.

Horsepower Curves – 1,750 RPM Input

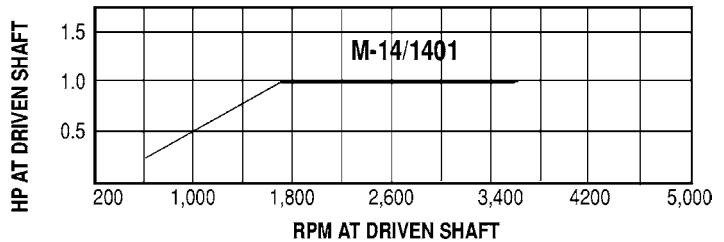

M-14 / 1401 Belt Selection Table

Center Distance & Belt Size			Driven Speed Range					
			1750 RPM Driver			1150 RPM Driver		
UPC Number	Belt Size	CD in	Min RPM	Max RPM	Ratio	Min RPM	Max RPM	Ratio
23255	1422V300	7.91	430	3,307	7.7 to 1	283	2,172	7.7 to 1
23257	1422V340	9.96	430	3,362	7.8 to 1	283	2,208	7.8 to 1
23258	1422V360	10.98	430	3,384	7.9 to 1	283	2,223	7.9 to 1
23259	1422V400	13.02	430	3,430	8.0 to 1	283	2,253	8.0 to 1
23260	1422V420	14.03	430	3,438	8.0 to 1	283	2,261	8.0 to 1
23261	1422V460	16.06	430	3,474	8.1 to 1	283	2,284	8.1 to 1

Center Distance & Belt Size			Driven Speed Range					
			1750 RPM Driver			1150 RPM Driver		
UPC Number	Belt Size	CD in	Min RPM	Max RPM	Ratio	Min RPM	Max RPM	Ratio
23262	1422V480	17.07	430	3,484	8.1 to 1	283	2,292	8.1 to 1
23263	1422V540	20.10	430	3,517	8.2 to 1	283	2,315	8.2 to 1
23264	1422V600	23.13	430	3,555	8.2 to 1	283	2,340	8.2 to 1
23265	1422V660	26.15	430	3,577	8.3 to 1	283	2,348	8.3 to 1
23266	1422V720	29.16	430	3,585	8.3 to 1	283	2,356	8.3 to 1
23267	1422V780	32.18	430	3,611	8.4 to 1	283	2,373	8.4 to 1

Notes: ■ The belt sizes shown in this chart are based upon initial drive set-up with the adjustable pulley at minimum pitch diameter (open) and the spring-loaded pulley at maximum pitch diameter (closed). The driven speed range and the resulting ratios shown in this chart are derived from mathematical calculations based upon exact center distances, constant motor speeds and manufacturers' belt specifications. Actual results will differ due to variations in any of these factors.

■ When referencing the Lovejoy UPC number in this table, include 685144 as a prefix to the number shown in the tables above.

Hi-Ratio Series

Fixed Center Distance
 3/4 through 3 HP
 1922V Belts
 Ratio up to 10.6 to 1

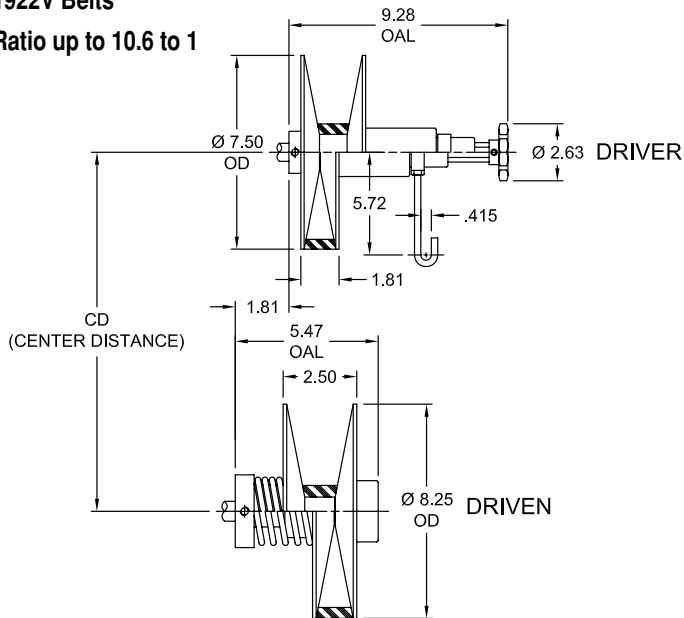

Model M-19 Adjustable Driver Pulley

UPC Number	Bore in	PD		HP Rating	
		Min in	Max in	1750 RPM	1150 RPM
43300	5/8	1.85	7.28	1 to 3	3/4 to 2
43301	3/4				
43302	7/8				
43303	1				

Note: ■ 17 turns of hand wheel required for full speed range.

Model 1902 Spring-Loaded Driven Pulley

UPC Number	Bore in	PD		HP Rating	
		Min in	Max in	1750 RPM	1150 RPM
43304	5/8	2.97	8.03	1 to 2	3/4 to 1-1/2
43305	3/4				
43306	7/8				
43307	1				
43308	1-1/8				

Model 1903 Spring-Loaded Driven Pulley

UPC Number	Bore in	PD		HP Rating	
		Min in	Max in	1750 RPM	1150 RPM
43309	5/8	2.97	8.03	3	2
43321	3/4				
43311	7/8				
43312	1				
43313	1-1/8				

Notes: ■ The above UPC numbers are for "C" Mount drives only.
 ■ Consult the factory for "Z" mount or thru bore applications.

Horsepower Curves - 1,750 RPM Input

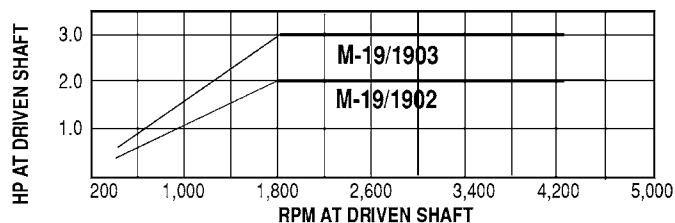

M-14 / 1401 Belt Selection Table

Center Distance & Belt Size			Driven Speed Range					
			1750 RPM Driver			1150 RPM Driver		
UPC Number	Belt Size	CD in	Min RPM	Max RPM	Ratio	Min RPM	Max RPM	Ratio
23278	1922V321	8.07	403	4,275	10.6 to 1	265	2,810	10.6 to 1
23280	1922V363	9.86	403	4,275	10.6 to 1	265	2,810	10.6 to 1
23281	1922V380	10.74	403	4,265	10.6 to 1	265	2,803	10.6 to 1
23282	1922V403	11.92	403	4,254	10.5 to 1	265	2,795	10.5 to 1
23283	1922V426	13.09	403	4,248	10.5 to 1	265	2,791	10.5 to 1
23285	1922V443	13.96	403	4,242	10.5 to 1	265	2,787	10.5 to 1
23286	1922V454	14.52	403	4,236	10.5 to 1	265	2,784	10.5 to 1
23287	1922V484	16.05	403	4,224	10.5 to 1	265	2,776	10.5 to 1

Center Distance & Belt Size			Driven Speed Range					
			1750 RPM Driver			1150 RPM Driver		
UPC Number	Belt Size	CD in	Min RPM	Max RPM	Ratio	Min RPM	Max RPM	Ratio
23288	1922V526	18.18	403	4,218	10.4 to 1	265	2,772	10.4 to 1
23290	1922V544	19.09	403	4,212	10.4 to 1	265	2,768	10.4 to 1
23292	1922V604	22.12	403	4,201	10.4 to 1	265	2,760	10.4 to 1
23293	1922V646	24.24	403	4,195	10.4 to 1	265	2,756	10.4 to 1
23294	1922V666	25.25	403	4,195	10.4 to 1	265	2,756	10.4 to 1
23295	1922V686	26.26	403	4,189	10.4 to 1	265	2,753	10.4 to 1
23296	1922V706	27.27	403	4,183	10.3 to 1	265	2,749	10.3 to 1
23298	1922V726	28.28	403	4,177	10.3 to 1	265	2,745	10.3 to 1

Notes: ■ The belt sizes shown in this chart are based upon initial drive set-up with the adjustable pulley at minimum pitch diameter (open) and the spring-loaded pulley at maximum pitch diameter (closed). The driven speed range and the resulting ratios shown in this chart are derived from mathematical calculations based upon exact center distances, constant motor speeds and manufacturers' belt specifications. Actual results will differ due to variations in any of these factors.

■ When referencing the Lovejoy UPC number in this table, include 685144 as a prefix to the number shown in the tables above.

Hi-Ratio Series

Fixed Center Distance
2 through 5 HP
2322V Belts

Ratio up to 11.5 to 1

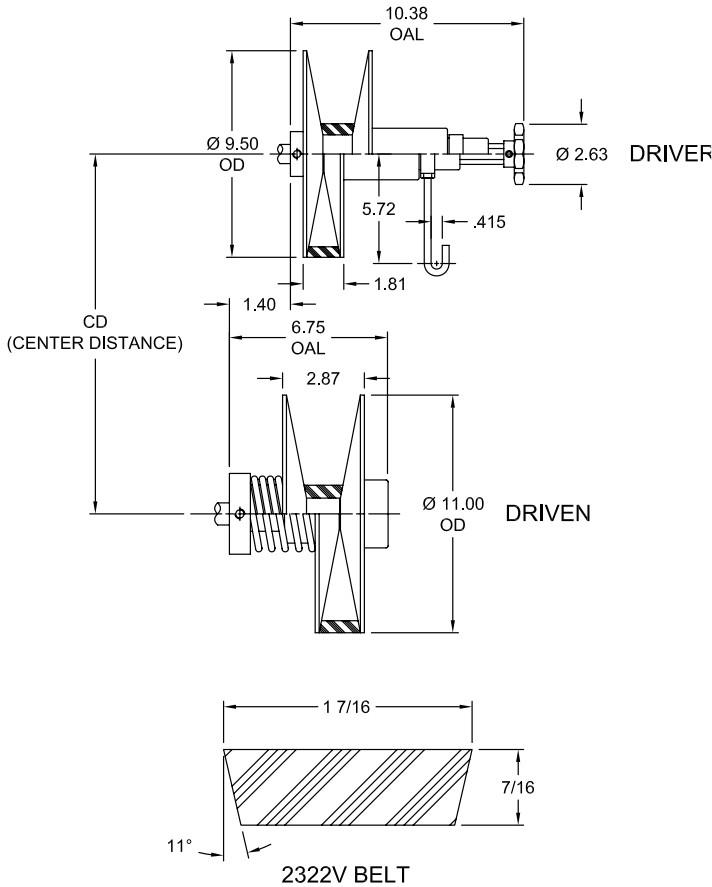

Model M-23 Adjustable Driver Pulley

UPC Number	Bore in	PD		HP Rating	
		Min in	Max in	1750 RPM	1150 RPM
43159	7/8	2.13	9.25	3 to 5	2 to 3
43160	1				
42483	1-1/8				

Note: ■ 22 turns of hand wheel required for full speed range.

Model 2303 Spring-Loaded Driven Pulley

UPC Number	Bore in	PD		HP Rating	
		Min in	Max in	1750 RPM	1150 RPM
43161	7/8	4.06	10.75	3	2
43162	1				
43163	1-1/8				

Model 2305 Spring-Loaded Driven Pulley

UPC Number	Bore in	PD		Horsepower Rating	
		Min in	Max in	1750 RPM	1150 RPM
43164	7/8	4.06	10.75	5	3
43165	1				
43166	1-1/8				

Notes: ■ The above UPC numbers are for "C" Mount drives only.
■ Consult the factory for "Z" mount or thru bore applications.

Horsepower Curves – 1,750 RPM Input

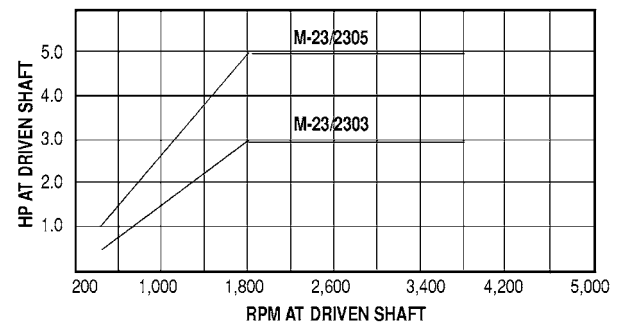

M-14 / 1401 Belt Selection Table

Center Distance & Belt Size			Driven Speed Range					
			1750 RPM Driver			1150 RPM Driver		
UPC Number	Belt Size	CD in	Min in	Max in	Ratio	Min in	Max in	Ratio
23315	2322V421	10.50	346	3,645	10.5 to 1	228	2,417	10.6 to 1
23317	2322V441	11.09	346	3,645	10.5 to 1	228	2,439	10.6 to 1
23318	2322V481	13.16	346	3,645	10.5 to 1	228	2,479	10.9 to 1
23319	2322V521	15.22	346	3,645	10.5 to 1	228	2,514	11.0 to 1
23320	2322V541	16.25	346	3,645	10.5 to 1	228	2,532	11.1 to 1
23322	2322V601	19.31	346	3,645	10.5 to 1	228	2,563	11.2 to 1
23324	2322V621	20.33	346	3,645	10.5 to 1	228	2,575	11.3 to 1
23326	2322V661	22.37	346	3,645	10.5 to 1	228	2,600	11.4 to 1

Center Distance & Belt Size			Driven Speed Range					
			1750 RPM Driver			1150 RPM Driver		
UPC Number	Belt Size	CD in	Min in	Max in	Ratio	Min in	Max in	Ratio
23327	2322V681	23.39	346	3,645	10.5 to 1	228	2,613	11.4 to 1
23328	2322V701	24.40	346	3,645	10.5 to 1	228	2,620	11.5 to 1
23329	2322V721	25.42	346	3,645	10.5 to 1	228	2,617	11.5 to 1
23330	2322V801	29.47	346	3,645	10.5 to 1	228	2,605	11.4 to 1
23331	2322V826	30.73	346	3,645	10.5 to 1	228	2,603	11.4 to 1
23333	2322V886	33.77	346	3,645	10.5 to 1	228	2,594	11.4 to 1
23335	2322V1001	39.56	346	3,645	10.5 to 1	228	2,586	11.3 to 1
23337	2322V1271	53.14	346	3,645	10.5 to 1	228	2,569	11.2 to 1

Notes: ■ The belt sizes shown in this chart are based upon initial drive set-up with the adjustable pulley at minimum pitch diameter (open) and the spring-loaded pulley at maximum pitch diameter (closed). The driven speed range and the resulting ratios shown in this chart are derived from mathematical calculations based upon exact center distances, constant motor speeds and manufacturers' belt specifications. Actual results will differ due to variations in any of these factors. Do not exceed 10,500 FPM rim speed with the driven pulley.

■ When referencing the Lovejoy UPC number in this table, include 685144 as a prefix to the number shown in the tables above.

1/3 through 3 HP Wide Variable Speed Belts

Hexadrive pulleys are the most durable variable speed pulleys available. The hexagon-shaped center shaft efficiently transmits torque through the six hex flats for maximum performance and long life. Internal drive keys, which tend to wear and shorten pulley life, are not required. In addition, because a resilient elastomer covers the shaft and eliminates metal to metal contact, no lubrication is necessary. The flanges are made of cast iron to provide a long-wearing belt contact area, and are precision-balanced for smooth operation.

Features

- Two styles available: one-side moveable for V-Flat drives and two-side moveable for V-V drives
- Uses variable speed belts
- Sizes range from 6 inches up to 12-1/2 inches in diameter
- Maximum rating of 30 HP @ 1,750 RPM
- Spring-loaded models have an easy removal feature.

Hexadrive pulleys are available for adjustable center as well as fixed center drives. This is the ultimate product for applications in hostile environments. Some typical applications include: agricultural equipment, food packaging machines, air handling systems, textile spinning frames, foundry snag grinders, mixers, and pumps.

Belt Selection

Hexadrive pulleys offer optimum speed ratios because they are used with wide variable speed belts. The pulley flanges are designed to match standard belt angle and width, so each pulley model must be matched to the correct belt to insure full speed range and maximum torque capacity.

Adjustable Center Drives

An adjustable center drive system consists of a spring-loaded Hexadrive pulley, a fixed diameter companion sheave and bushing, an adjustable motor base, and a variable speed belt. Two types of drive packages are available—the V-V and the V-Flat drives. The V-V drive includes a two-side moveable Hexadrive pulley driving to a grooved companion sheave. The V-Flat drive utilizes a one-side moveable Hexadrive pulley driving to a flat-faced companion sheave. For a complete explanation of V-V and V-Flat drives, refer to page VSD-4, and to order bushings, see page SF-17. Generally, a V-V drive offers greater torque capacity, while a V-Flat drive is more compact and economical.

Fixed Center Drives

Fixed center, or compound, drives offer greater driven speed range in a compact space. There are three mechanically-adjustable Hexadrive pulley models available which, when combined with a spring-loaded Hexadrive pulley, provide drive packages ranging from 3/4 up to 30 horsepower. There is also a "non-Hex" adjustable pulley, the Model M-007, which can be teamed with a Hexadrive spring-loaded pulley for 1/2 and 3/4 HP motors. This package is unique because it is a two-side moveable fixed center drive.



Hexadrive Series



Typical V-Flat Drive



Typical V-V Drive

VSD

Variable Speed Drives

Hexadrive Series

Overview

The typical Hexadrive fixed center drive consists of an adjustable pulley mounted on the motor shaft, a spring-loaded pulley on the driven shaft, a variable speed belt and a torque arm bracket. This bracket prevents the manual pulley handwheel from spinning, so speed can be changed while the motor is running. The spring-loaded driven pulley compensates for belt slack or tightening when the adjustable pulley is opened or closed. Much of the driven speed range will be greater than motor speed.

It is important to know the mounting configuration when designing a Hexadrive fixed center drive or selecting a replacement pulley. There are two basic styles, designated as "C" and "Z" mountings. The adjustable pulley is the same for either, but the driven spring-loaded pulley is different. The drive selection tables that follow in this catalog indicate which model to use in either case.

The standard adjustable pulley is the "HM" series, with a handwheel control. There are two variations which give the option of speed change by electric remote control ("HEC" series) or by using an external linear actuator ("HLA" series).

Easy Removal Feature

All Hexadrive spring-loaded pulleys are designed with an easy removal feature, which minimizes the chance of damage to the pulley or shaft. This damage can result from hammering and prying on the pulley.

While this feature is built into the smaller pulleys, all 5 HP and larger pulleys require the use of our Easy Removal Kit accessory because they feature "through bores." The kit consists of a special nut and retaining ring that fit into the counterbore end of the pulley, retaining ring pliers, and a threaded puller rod. Two types of kits are available – the table below shows the correct kit for each pulley model.

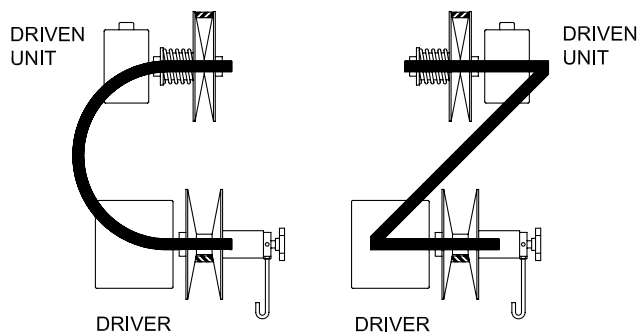

C and Z Mounting



Typical Hexadrive Fixed Center Drive

UPC Number	Easy Removal Kit Model Number	For Pulley Model Number
685144 20723	030880H	12904, 12905, 12907, 22904, 22905, 22907, 32904, 32905
685144 20726	020979H	13207, 13210, 13220, 13230, 23207, 23210, 23220, 23230, 14407, 14410, 14420, 14430, 24407, 24410, 24420, 24430, 34407, 34410, 34420



Easy Removal Kit

VSD

Hexadrive Series

One-Side Moveable
 Adjustable Center Distance
 1/3 through 1 HP
 1422V Belts
 Ratio 2.6 to 1

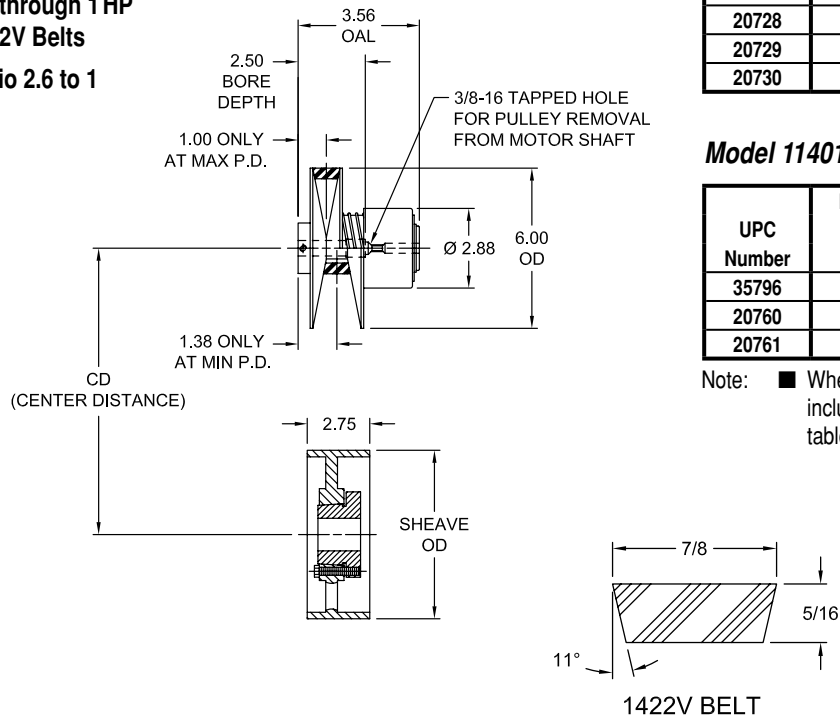

Model 11407 Spring-Loaded Driver Pulley

UPC Number	Bore in	PD		Torque Capacity in-lb	HP Rating	
		Min in	Max in		1750 RPM	1150 RPM
20728	5/8	2.21	5.80	27	1/2 to 3/4	1/3 to 1/2
20729	3/4					
20730	7/8					

Model 11401 Spring-Loaded Driver Pulley

UPC Number	Bore in	PD		Torque Capacity in-lb	HP Rating	
		Min in	Max in		1750 RPM	1150 RPM
35796	5/8	2.21	5.80	36	1	3/4
20760	3/4					
20761	7/8					

Note: ■ When referencing the Lovejoy UPC number in this table, include 685144 as a prefix to the number shown in the tables above.

Horsepower Curves – 1,750 RPM Input

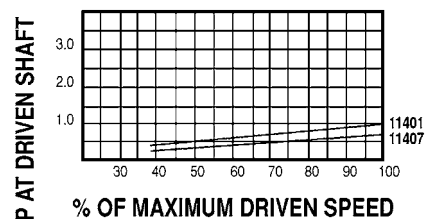

11407 / 11401 Driven Sheave Selection Table

Flat Driven Sheave			Driven Speed Range				Driven Torque	
UPC Number	Model	PD in	1750 RPM Motor		1150 RPM Motor		11407 in-lb	11401 in-lb
			Min RPM	Max RPM	Min RPM	Max RPM		
19656	2.75F4SD	4.42	875	2,295	575	1,505	18	23
19660	2.75F6SD	6.42	605	1,580	395	1,035	26	34
19662	2.75F7SD	7.42	525	1,365	345	900	30	39
19664	2.75F8SD	8.42	460	1,205	305	790	34	45
19666	2.75F9SD	9.42	415	1,075	270	705	40	52
19668	2.75F10SD	10.42	375	970	245	640	45	57
19672	2.75F12SD	12.42	315	815	205	535	56	70
19674	2.75F14SF	14.42	265	700	180	460	62	80
19676	2.75F16SF	16.42	240	615	155	405	72	93

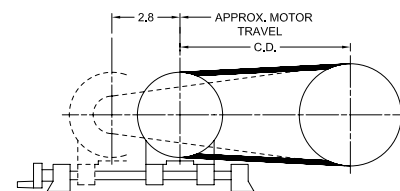

NEMA Motor Frame	Recommended Motor Bases
48, 56	48 / 56, 200
43T	145 / 60, SMB 143

11407 / 11401 Belt Selection Table

UPC Number	Belt Size	Minimum Center Distance by Selected Sheave Size									
		2.75F4SD in	2.75F6SD in	2.75F7SD in	2.75F8SD in	2.75F9SD in	2.75F10SD in	2.75F12SD in	2.75F14SF in	2.75F16SF in	
23255	1422V300	6.9	—	—	—	—	—	—	—	—	
23258	1422V360	9.9	8.4	7.6	—	—	—	—	—	—	
23260	1422V420	13.0	11.4	10.6	9.7	8.9	—	—	—	—	
23262	1422V480	16.0	14.4	13.6	12.8	11.9	11.0	—	—	—	
23263	1422V540	19.0	17.4	16.6	15.8	14.9	14.1	12.3	10.4	—	
23265	1422V660	25.0	23.4	22.6	21.8	20.9	20.1	18.4	16.6	14.7	
23266	1422V720	28.0	26.4	25.6	24.8	24.0	23.1	21.4	19.6	17.8	
23267	1422V780	31.0	29.4	28.6	27.8	27.0	26.1	24.4	22.6	20.8	

Note: ■ When referencing the Lovejoy UPC number in this table, include 685144 as a prefix to the number shown in the tables above.

Hexadrive Series

One-Side Moveable
 Adjustable Center Distance
 1 through 3 HP
 1922V Belts
 Ratio 3 to 1

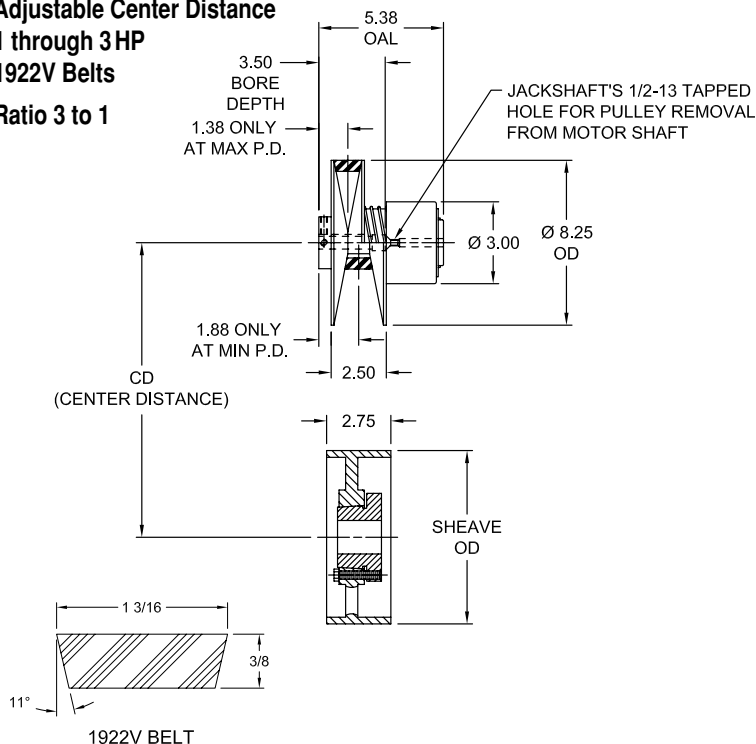

Model 11901 Spring-Loaded Driver Pulley

UPC Number	Bore in	PD		Torque Capacity in-lb	HP Rating	
		Min in	Max in		1750 RPM	1150 RPM
20769	5/8	2.70	8.03	54	1-1/2	1
20770	3/4					
20771	7/8					
20773	1					
20774	1-1/8					

Model 11902 Spring-Loaded Driver Pulley

UPC Number	Bore in	PD		Torque Capacity in-lb	HP Rating	
		Min in	Max in		1750 RPM	1150 RPM
20801	5/8	2.70	8.03	72	2	1-1/2
20802	3/4					
20803	7/8					
20805	1					
20806	1-1/8					

Model 11903 Spring-Loaded Driver Pulley

UPC Number	Bore in	PD		Torque Capacity in-lb	HP Rating	
		Min in	Max in		1750 RPM	1150 RPM
20826	5/8	2.70	8.03	108	3	2
20827	3/4					
20828	7/8					
20830	1					
20831	1-1/8					

Horsepower Curves – 1,750 RPM Input

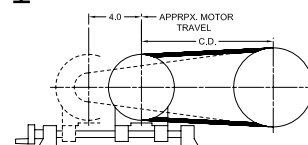
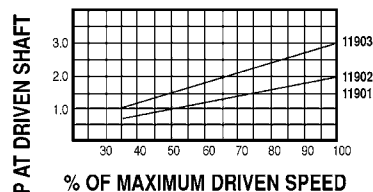

11901 / 11902 / 11903 Driven Sheave Selection Table

Flat Driven Sheave		Driven Speed Range				Driven Torque			
UPC Number	Model	PD in	1750 RPM Motor		1150 RPM Motor		11901	11902	11903
			Min RPM	Max RPM	Min RPM	Max RPM	in-lb	in-lb	in-lb
19660	2.75F6SD	6.54	720	2,145	475	1,410	34	46	68
19662	2.75F7SD	7.54	630	1,860	415	1,225	40	53	80
19664	2.75F8SD	8.54	555	1,645	360	1,080	45	61	90
19666	2.75F9SD	9.54	495	1,470	325	965	54	73	108
19668	2.75F10SD	10.54	450	1,330	295	875	60	81	120
19672	2.75F12SD	12.54	380	1,120	250	735	72	97	144
19674	2.75F14SF	14.54	325	965	215	635	85	113	170
19676	2.75F16SF	16.54	285	850	185	555	96	130	192
19678	2.75F18SF	18.54	255	755	170	495	108	146	216

11901 / 11902 / 11903 Belt Selection Table

UPC Number	Belt Size	Minimum Center Distance by Selected Sheave Size									
		2.75F6SD in	2.75F7SD in	2.75F8SD in	2.75F9SD in	2.75F10SD in	2.75F12SD in	2.75F14SF in	2.75F16SF in	2.75F18SF in	
23282	1922V403	8.7	—	—	—	—	—	—	—	—	
23285	1922V443	10.7	9.9	9.1	—	—	—	—	—	—	
23287	1922V484	12.7	12.0	11.2	10.4	9.5	—	—	—	—	
23290	1922V544	15.7	15.0	14.2	13.4	12.6	10.9	—	—	—	
23293	1922V646	20.8	20.1	19.3	18.5	17.7	16.0	14.2	—	—	
23295	1922V686	22.8	22.1	21.3	20.5	19.7	18.0	16.3	14.5	—	
23298	1922V726	24.8	24.1	23.3	22.5	21.7	20.0	18.3	16.5	14.7	
23300	1922V806	28.8	28.1	27.3	26.5	25.7	24.0	22.3	20.6	18.7	

Note: ■ When referencing the Lovejoy UPC number in this table, include 685144 as a prefix to the number shown in the tables above.

NEMA Motor Frame	Recommended Motor Bases
56, 143T	145 / 60, SMB 143
145T, 182T	301, SMB 184

VSD

Hexadrive Series

One-Side Moveable
Adjustable Center Distance
3 through 7-1/2 HP
2926V Belts
Ratio 3 to 1

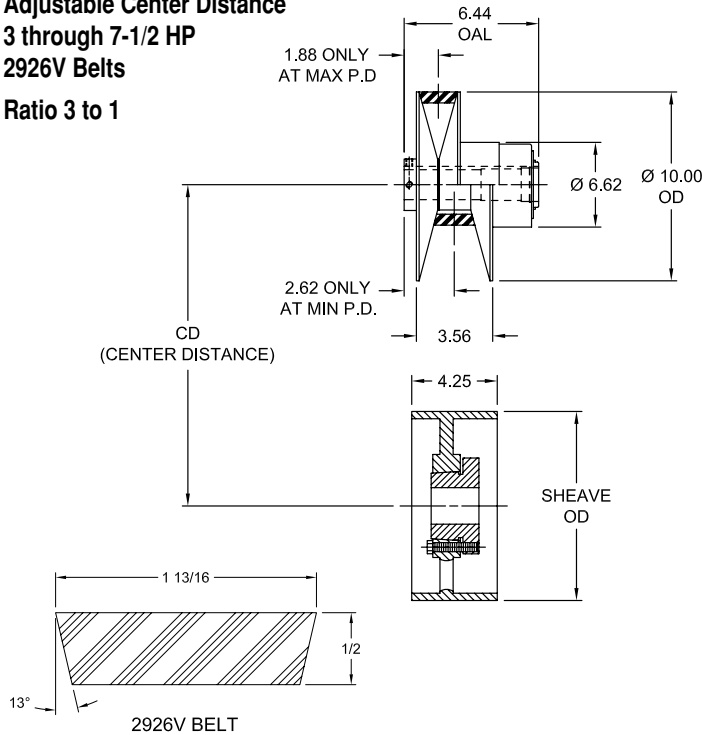

Model 12905 Spring-Loaded Driver Pulley

UPC Number	Bore in	PD		Torque Capacity in-lb	HP Rating	
		Min in	Max in		1750 RPM	1150 RPM
37331	1					
21870	1-1/8	3.28	9.70	180	5	3
37350	1-3/8					

Model 12907 Spring-Loaded Driver Pulley

UPC Number	Bore in	PD		Torque Capacity in-lb	HP Rating	
		Min in	Max in		1750 RPM	1150 RPM
43100	1					
37336	1-1/8	3.28	9.70	270	7-1/2	5
21876	1-3/8					

Horsepower Curves – 1,750 RPM Input

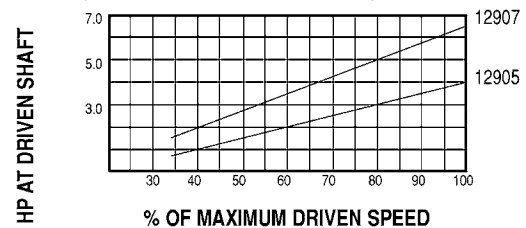

12905 / 12907 Driven Sheave Selection Table

Flat Driven Sheave			Driven Speed Range				Driven Torque	
UPC Number	Model	PD in	1750 RPM Motor		1150 RPM Motor		12905 in-lb	12907 in-lb
			Min RPM	Max RPM	Min RPM	Max RPM		
19630	4.25F8SD*	8.7	660	1,950	435	1,280	126	*
19634	2.75F10SD	10.7	540	1,585	355	1,040	166	252
19639	2.75F12SF	12.7	455	1,335	300	875	200	302
19641	2.75F14SF	14.7	390	1,155	260	755	233	353
19643	2.75F16SF	16.7	345	1,015	230	665	266	403
19645	2.75F18SF	18.7	310	905	205	595	300	453
19647	2.75F20SF	20.7	280	820	185	535	333	504

Note: * indicates: That 4.25F8SD is NOT recommended for use with 7-1/2 HP drive. This combination could cause belt slippage.

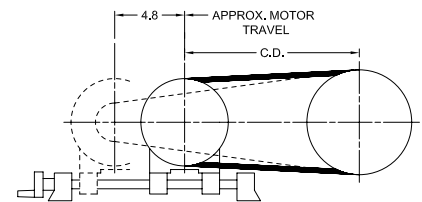

NEMA Motor Frame	Recommended Motor Bases
56, 143T	145- 60, SMB 143
145T, 182T	301, SMB 184

12905 / 12907 Belt Selection Table

UPC Number	Belt Size	Minimum Center Distance by Selected Sheave Size						
		2.75F8SD in	2.75F10SD in	2.75F12SD in	2.75F14SF in	2.75F16SF in	2.75F18SF in	2.75F20SF in
23350	2926V486	9.8	—	—	—	—	—	—
23353	2926V546	12.8	11.3	—	—	—	—	—
23357	2926V606	15.8	14.3	12.6	—	—	—	—
23361	2926V666	18.8	17.3	15.6	13.9	—	—	—
23364	2926V726	21.8	20.3	18.6	17.0	15.2	—	—
23367	2926V786	24.8	23.3	21.6	20.0	18.3	16.5	—
23369	2926V856	28.3	26.8	25.2	23.5	21.8	20.0	18.2
23371	2926V906	30.8	29.3	27.7	26.0	24.3	22.5	20.8
23372	2926V966	33.8	32.3	30.7	29.0	27.3	25.6	23.8

Note: ■ When referencing the Lovejoy UPC number in this table, include 685144 as a prefix to the number shown in the tables above.



Variable Speed Drives

Hexadrive Models 13207, 13210, 13220 and 13230

Item Selection

Hexadrive Series

One-Side Moveable
Adjustable Center Distance
5 through 30HP
3230 HV Belts
Ratio 2.3 to 1

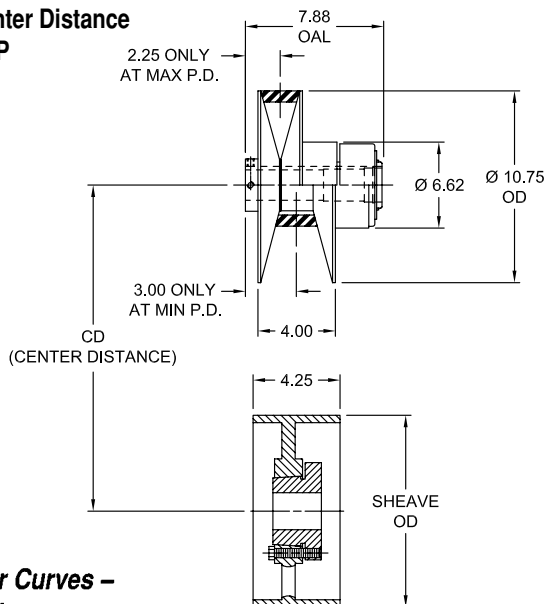

Horsepower Curves – 1,750 RPM Input

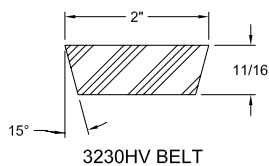
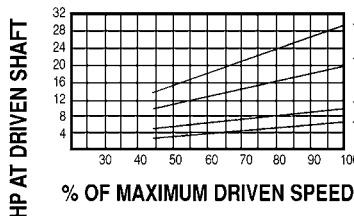

Model 13207 Spring-Loaded Driver Pulley

UPC Number	Bore in	PD		Torque Capacity in-lb	HP Rating	
		Min in	Max in		1750 RPM	1150 RPM
42433	1-1/8	4.43	10.35	270	7-1/2	5
37344	1-3/8					
37345	1-5/8					

Model 13210 Spring-Loaded Driver Pulley

UPC Number	Bore in	PD		Torque Capacity in-lb	HP Rating	
		Min in	Max in		1750 RPM	1150 RPM
21892	1-3/8	4.43	10.35	360	10	7-1/2
21893	1-5/8					
21894	1-7/8					

Model 13220 Spring-Loaded Driver Pulley

UPC Number	Bore in	PD		Torque Capacity in-lb	HP Rating	
		Min in	Max in		1750 RPM	1150 RPM
21915	1-3/8	4.43	10.35	720	15 to 20	10 to 15
21916	1-5/8					
27974	1-7/8					

Model 13230 Spring-Loaded Driver Pulley

UPC Number	Bore in	PD		Torque Capacity in-lb	HP Rating	
		Min in	Max in		1750 RPM	1150 RPM
37348	1-3/8	4.43	10.35	1,080	25 to 30	20 to 25
37349	1-5/8					
42439	1-7/8					
42440	2-1/8					

13207 / 13210 / 13220 / 13230 Driven Sheave Selection Table

Flat Driven Sheave			Driven Speed Range				Driven Torque			
UPC Number	Model	PD in	1750 RPM Motor		1550 RPM Motor		13207	13210	13220	13230
			Min RPM	Max RPM	Min RPM	Max RPM	in-lb	in-lb	in-lb	in-lb
19639	4.25F12SF*	13.0	600	1,390	395	915	243	324	*	*
19641	4.25F14SF	15.0	520	1,205	340	790	283	378	756	1,134
19643	4.25F16SF	17.0	460	1,065	300	700	324	432	864	1,296
19645	4.25F18SF	19.0	410	950	270	625	364	486	972	1,458
19647	4.25F20SF	21.0	370	860	245	565	405	540	1,080	1,620
19651	4.25F24SF	25.0	310	720	205	475	486	648	1,296	1,944

Note: * indicates: That 4.25F12SF is NOT recommended for use with 15 to 30 HP drive. This combination could cause belt slippage.

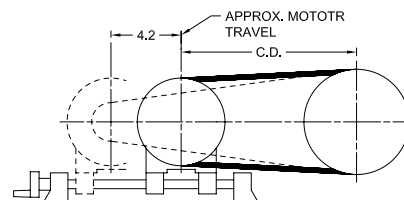

NEMA Motor Frame	Recommended Motor Bases
213T, 215T	305-8, SMB 254
254T	310-30, SMB 254
256T, 284T	310-30
286T, 324T	

13207 / 13210 / 13220 / 13230 Belt Selection Table

UPC Number	Belt Size	Minimum Center Distance by Selected Sheave Size					
		4.25F12SF in	4.25F14SF in	4.25F16SF in	4.25F18SF in	4.25F20SF in	4.25F24SF in
23382	3230HV620	12.7	—	—	—	—	—
23384	3230HV670	15.2	13.5	—	—	—	—
23387	3230HV723	17.9	16.2	14.5	—	—	—
23389	3230HV821	22.8	21.1	19.4	17.6	—	—
23390	3230HV856	24.5	22.9	21.2	19.4	17.6	—
23392	3230HV931	28.3	26.6	24.9	23.2	21.4	17.7
23393	3230HV960	29.7	28.1	26.4	24.7	22.9	19.2

Note: When referencing the Lovejoy UPC number in this table, include 685144 as a prefix to the number shown in the tables above.



Variable Speed Drives

Hexadrive Models 14407, 14410, 14420 and 14430

Item Selection

Hexadrive Series

One-Side Moveable
Adjustable Center Distance
5 through 30HP
4430 V Belts
Ratio 2.7 to 1

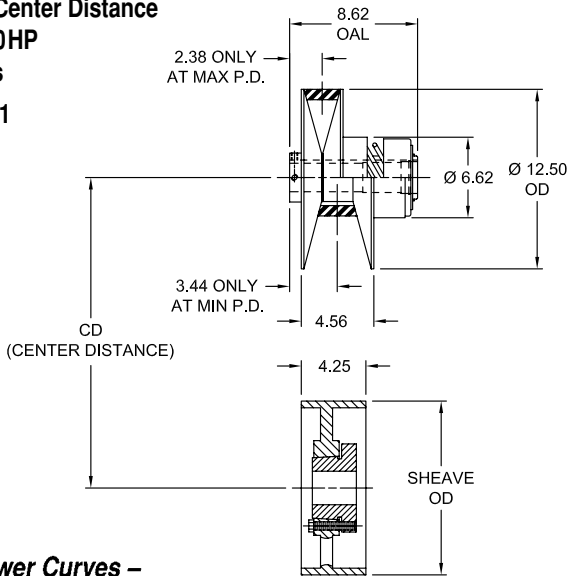

Horsepower Curves – 1,750 RPM Input

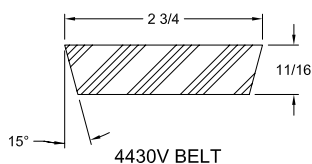
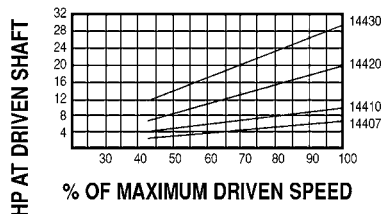

Model 14407 Spring-Loaded Driver Pulley

UPC Number	Bore in	PD		Torque Capacity in-lb	HP Rating	
		Min in	Max in		1750 RPM	1150 RPM
42467	1-1/8	4.43	12.10	270	7-1/2	5
37360	1-3/8					
37361	1-5/8					

Model 14410 Spring-Loaded Driver Pulley

UPC Number	Bore in	PD		Torque Capacity in-lb	HP Rating	
		Min in	Max in		1750 RPM	1150 RPM
21970	1-1/8	4.43	12.10	360	10	7-1/2
21971	1-3/8					
37351	1-5/8					

Model 14420 Spring-Loaded Driver Pulley

UPC Number	Bore in	PD		Torque Capacity in-lb	HP Rating	
		Min in	Max in		1750 RPM	1150 RPM
21994	1-1/8	4.43	12.10	720	15 to 20	10 to 15
21996	1-3/8					
21997	1-5/8					

Model 14430 Spring-Loaded Driver Pulley

UPC Number	Bore in	PD		Torque Capacity in-lb	HP Rating	
		Min in	Max in		1750 RPM	1150 RPM
37353	1-3/8	4.43	12.10	1,080	25 to 30	20 to 25
22006	1-5/8					
22007	1-7/8					
22008	2-1/8					

14407 / 14410 / 14420 / 14430 Driven Sheave Selection Table

Flat Driven Sheave			Driven Speed Range				Driven Torque			
UPC Number	Model	PD in	1750 RPM Motor		1150 RPM Motor		14407	14410	14420	14430
			Min RPM	Max RPM	Min RPM	Max RPM	in-lb	in-lb	in-lb	in-lb
19639	4.25F12SF*	13.0	600	1,630	395	1,070	243	324	*	*
19641	4.25F14SF	15.0	520	1,410	340	925	283	378	756	1,134
19673	4.25F16SF	17.0	460	1,245	300	815	324	432	864	1,296
19645	4.25F18SF	19.0	410	1,115	270	730	364	486	972	1,458
14647	4.25F20SF	21.0	370	1,005	245	660	405	540	1,080	1,620
19651	4.25F24SF	25.0	310	845	205	555	486	648	1,296	1,944

Note: * indicates: That 4.25F12SF is NOT recommended for use with 15 to 30 HP drive. This combination could cause belt slippage.

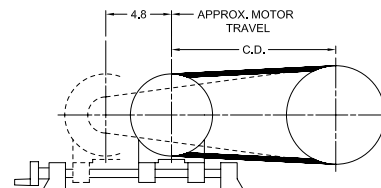

NEMA Motor Frame	Recommended Motor Bases
213T, 215T	305-8, SMB 254
254T	310-30, SMB 254
256T, 284T	310-30
286T, 324T	

14407 / 14410 / 14420 / 14430 Belt Selection Chart

UPC Number	Belt Size	Minimum Center Distance by Selected Sheave Size					
		4.25F12SF in	4.25F14SF in	4.25F16SF in	4.25F18SF in	4.25F20SF in	4.25F24SF in
23403	4430V660	13.3	—	—	—	—	—
23407	4430V718	16.2	14.6	—	—	—	—
23413	4430V790	19.8	18.2	16.5	—	—	—
23414	4430V850	22.8	21.2	19.5	17.8	—	—
23416	4430V910	25.8	24.2	22.5	20.8	19.1	—
23418	4430V970	28.8	27.2	25.5	23.8	22.1	—
23421	4430V1030	31.8	30.2	28.5	26.9	25.1	21.5
23423	4430V1090	34.8	33.2	31.6	29.9	28.2	24.6

Note: ■ When referencing the Lovejoy UPC number in this table, include 685144 as a prefix to the number shown in the tables above.



Variable Speed Drives

Hexadrive Models 21407 and 21401

Item Selection

Hexadrive Series

Two-Side Moveable
Adjustable Center Distance
1/3 through 1HP
1422V Belts
Ratio 2.6 to 1

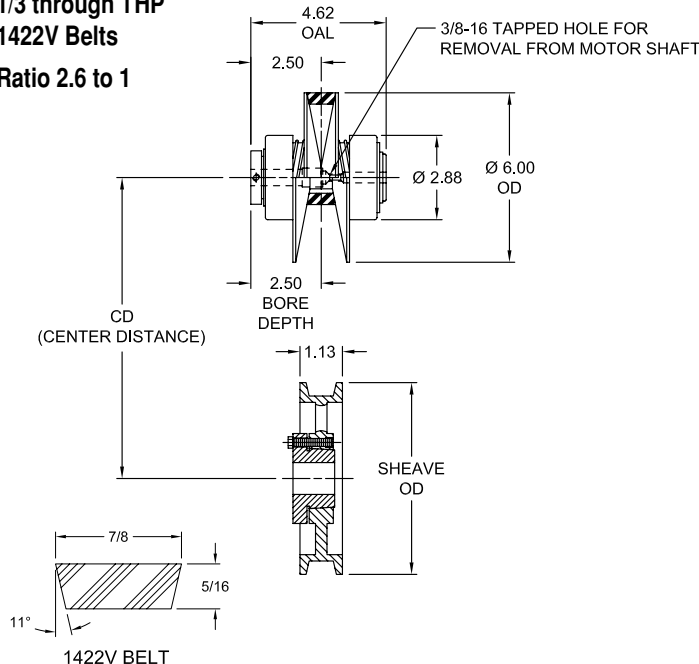

Model 21407 Spring-Loaded Driver Pulley

UPC Number	Bore in	PD		Torque Capacity in-lb	HP Rating	
		Min in	Max in		1750 RPM	1150 RPM
21089	5/8	2.21	5.80	27	1/2 to 3/4	1/3 to 1/2
21090	3/4					
21091	7/8					

Model 21401 Spring-Loaded Driver Pulley

UPC Number	Bore in	PD		Torque Capacity in-lb	HP Rating	
		Min in	Max in		1750 RPM	1150 RPM
35797	5/8	2.21	5.80	36	1	3/4
21106	3/4					
21107	7/8					

Horsepower Curves - 1,750 RPM Input

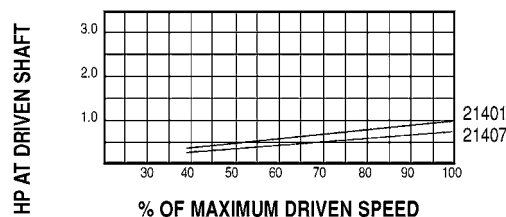

21407 / 21401 Driven Sheave Selection Table

Grooved Driven Sheave		Driven Speed Range				Driven Torque		
UPC Number	Model	PD in	1750 RPM Motor		1550 RPM Motor		21407 in-lb	21401 in-lb
			Min RPM	Max RPM	Min RPM	Max RPM		
19493	1422G5.5SH	5.3	730	1,915	480	1,255	26	34
19495	1422G6SH	5.8	670	1,750	440	1,150	28	38
19497	1422G7SH	6.8	570	1,490	375	980	34	44
19499	1422G8SH	7.8	500	1,300	330	855	39	51
19501	1422G9SH	8.8	420	1,150	290	755	44	57
19503	1422G10SH	9.8	395	1,035	260	680	49	64
19507	1422G11SH	10.8	360	940	235	615	54	72
19509	1422G12SH	11.8	330	860	215	565	59	77
19511	1422G14SH	13.8	280	735	185	480	69	90

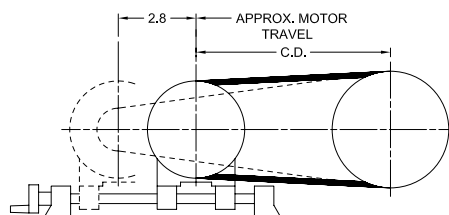

NEMA Motor Frame	Recommended Motor Bases
48, 56	48/56, 200
	135, SMB 143
143T	145-60 SMB 143

21407 / 21401 Belt Selection Table

UPC Number	Belt Size	Minimum Center Distance by Selected Sheave Size								
		1422G-5.5SH in	1422G-6SH in	1422G-7SH in	1422G-8SH in	1422G-9SH in	1422G-10SH in	1422G-11SH in	1422G-12SH in	1422G-14SH in
23255	1422V300	6.3	—	—	—	—	—	—	—	—
23258	1422V360	7.3	8.9	8.1	7.3	—	—	—	—	—
23260	1422V420	12.3	11.9	11.1	10.3	9.4	8.6	—	—	—
23252	1422V480	15.3	14.9	14.1	13.3	12.4	11.6	10.7	9.8	—
23263	1422V540	18.3	14.9	17.1	16.3	15.4	14.6	13.7	12.8	11.0
23265	1422V660	24.3	23.9	23.1	22.3	21.5	20.6	19.8	18.9	17.1
23266	1422V720	27.3	26.9	26.1	25.3	24.5	23.6	22.8	21.9	20.2
23267	1422V780	30.3	29.9	29.1	28.3	27.5	26.6	25.8	24.9	23.2

Note: ■ When referencing the Lovejoy UPC number in this table, include 685144 as a prefix to the number shown in the tables above.



Variable Speed Drives

Hexadrive Models 21901, 21902 and 21903

Item Selection

Hexadrive Series

Two-Side Moveable
Adjustable Center Distance
1 through 3 HP
1922V Belts
Ratio 3 to 1

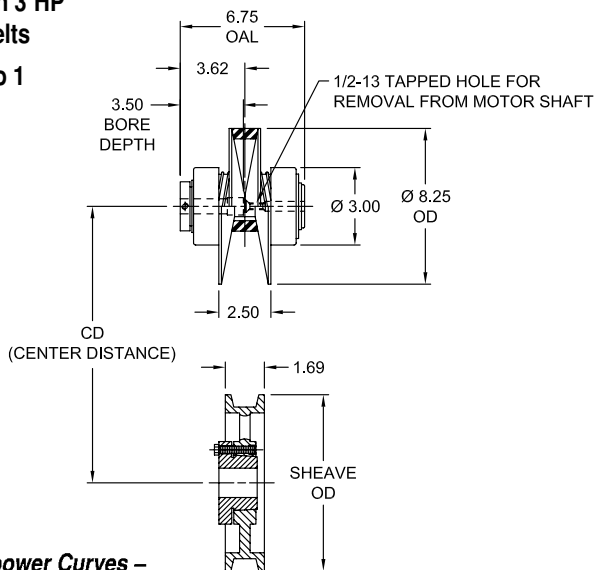

Horsepower Curves –
1,750 RPM Input

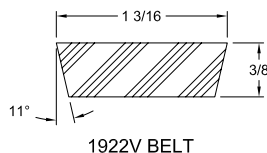
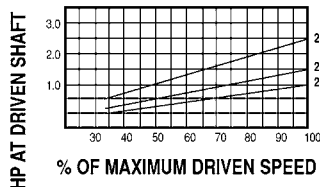

Model 21901 Spring-Loaded Driver Pulley

UPC Number	Bore in	PD		Torque Capacity in-lb	HP Rating	
		Min in	Max in		1750 RPM	1150 RPM
21111	5/8	2.70	8.03	54	1-1/2	1
21112	3/4					
21113	7/8					
21114	1					
21115	1-1/8					

Model 21902 Spring-Loaded Driver Pulley

UPC Number	Bore in	PD		Torque Capacity in-lb	HP Rating	
		Min in	Max in		1750 RPM	1150 RPM
26344	5/8	2.70	8.03	72	2	1-1/2
21132	3/4					
21133	7/8					
21135	1					
21136	1-1/8					

Model 21903 Spring-Loaded Driver Pulley

UPC Number	Bore in	PD		Torque Capacity in-lb	HP Rating	
		Min in	Max in		1750 RPM	1150 RPM
27323	5/8	2.70	8.03	108	3	2
21139	3/4					
21141	7/8					
21142	1					
21143	1-1/8					

21901 / 21902 / 21903 Driven Sheave Selection Table

Grooved Driven Sheave			Driven Speed Range				Driven Torque		
UPC Number	Model	PD in	1750 RPM Motor		1150 RPM Motor		21901 in-lb	21902 in-lb	21903 in-lb
			Min RPM	Max RPM	Min RPM	Max RPM			
19520	1922G7SK	6.78	700	2,070	460	1,360	46	61	92
19522	1922G8SK	7.78	610	1,805	400	1,185	52	70	104
19523	1922G9SK	8.78	540	1,600	355	1,050	60	79	120
19524	1922G10SK	9.78	485	1,435	315	940	66	88	132
19528	1922G12SK	11.78	400	1,190	265	780	80	106	160
19529	1922G14SK	13.78	345	1,020	225	670	93	124	186
19531	1922G16SK	15.78	300	890	200	585	106	142	212

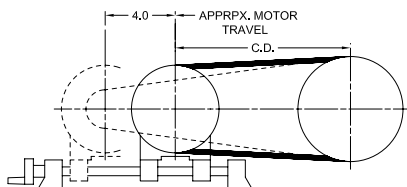

NEMA Motor Frame	Recommended Motor Bases
56, 143T	145-60, SMB 143
145T, 182T	301, SMB 184

21901 / 21902 / 21903 Belt Selection Table

UPC Number	Belt Size	Minimum Center Distance by Selected Sheave Size							
		1922G7SK in	1922G8SK in	1922G9SK in	1922G10SK in	1922G12SK in	1922G14SK in	1922G16SK in	
23282	1922V403	8.5	—	—	—	—	—	—	
23285	1922V443	10.2	9.7	8.9	—	—	—	—	
23287	1922V484	12.5	11.8	11.1	10.2	—	—	—	
23290	1922V544	15.6	14.8	14.1	13.2	11.5	—	—	
23293	1922V646	20.7	19.9	17.1	18.3	16.6	14.9	13.1	
23295	1922V686	22.7	21.9	23.1	20.3	18.6	16.9	15.2	
23298	1922V726	24.7	23.9	26.1	22.3	20.6	18.9	17.2	
23300	1922V806	28.7	27.9	29.1	26.3	24.7	23.0	21.2	

Note: ■ When referencing the Lovejoy UPC number in this table, include 685144 as a prefix to the number shown in the tables above.



Variable Speed Drives

Hexadrive Models 22905 and 22907

Item Selection

Hexadrive Series

Two-Side Moveable
Adjustable Center Distance
3 through 7-1/2 HP
2926V Belts
Ratio 3 to 1

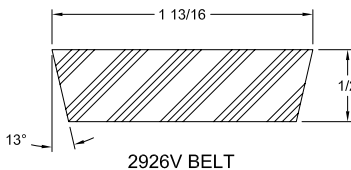
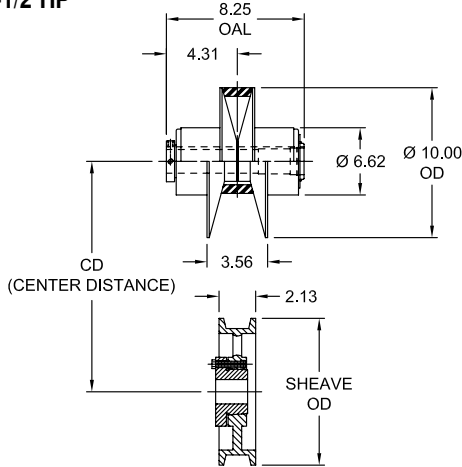

Model 22905 Spring-Loaded Driver Pulley

UPC Number	Bore in	PD		Torque Capacity in-lb	HP Rating	
		Min in	Max in		1750 RPM	1150 RPM
37333	1	3.28	9.70	180	5	3
37334	1-1/8					
37335	1-3/8					

Model 22907 Spring-Loaded Driver Pulley

UPC Number	Bore in	PD		Torque Capacity in-lb	HP Rating	
		Min in	Max in		1750 RPM	1150 RPM
43101	1	3.28	9.70	270	7-1/2	5
37338	1-1/8					
37339	1-3/8					

Horsepower Curves – 1,750 RPM Input

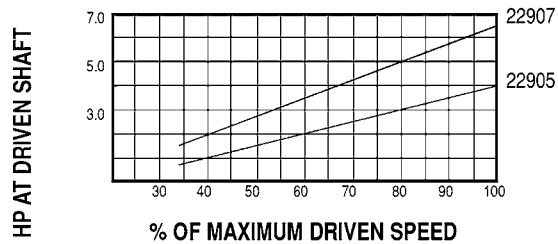

22905 / 22907 Driven Sheave Selection Table

Grooved Driven Sheave			Driven Speed Range				Driven Torque	
UPC Number	Model	PD in	1750 RPM Motor		1150 RPM Motor		22905 in-lb	22907 in-lb
			Min RPM	Max RPM	Min RPM	Max RPM		
19561	2926G8SK	7.7	7445	2,205	490	1,445	142	215
19563	2926G9SK	8.7	660	1,950	435	1,280	161	243
19565	2926G10SK	9.7	595	1,750	390	1,150	180	271
19567	2926G12SK	11.7	495	1,450	325	950	216	327
19569	2926G14SK	13.7	420	1,235	275	810	253	383
19572	2926G15SK	15.7	370	1,080	240	710	290	440
19575	2926G18SK	17.7	325	960	215	630	327	495

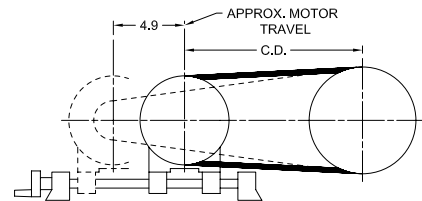

NEMA Motor Frame	Recommended Motor Bases
184T	305-8, SMB 184
213T, 215T	305-8, SMB 254

22905 / 22907 Belt Selection Table

UPC Number	Belt Size	Minimum Center Distance by Selected Sheave Size						
		2926G8SK in	2926G9SK in	2926G10SK in	2926G12SK in	2926G14SK in	2926G16SK in	2926G18SK in
23350	2926V486	10.6	9.8	—	—	—	—	—
23353	2926V546	13.6	12.8	12.1	—	—	—	—
23357	2926V606	16.6	15.8	15.1	13.5	—	—	—
23361	2926V666	19.6	18.8	18.1	16.5	14.8	—	—
23364	2926V726	22.6	21.8	21.1	19.5	17.8	16.1	14.3
23367	2926V786	25.6	24.8	24.1	22.5	20.8	19.1	17.4
23369	2926V856	29.1	28.3	27.6	26.0	24.3	22.6	20.9
23371	2926V906	31.6	30.8	30.1	28.5	26.8	25.2	23.4
23372	2926V966	34.6	33.8	33.1	31.5	29.8	28.2	26.4

Note: ■ When referencing the Lovejoy UPC number in this table, include 685144 as a prefix to the number shown in the tables above.



Variable Speed Drives

Hexadrive Models 23207, 23210, 23220 and 23230

Item Selection

Hexadrive Series

Two-Side Moveable
Adjustable Center Distance
5 through 30 HP
3230 HV Belts
Ratio 2.3 to 1

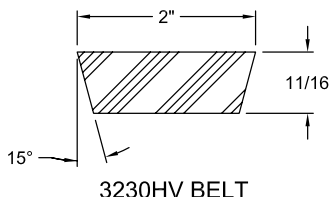
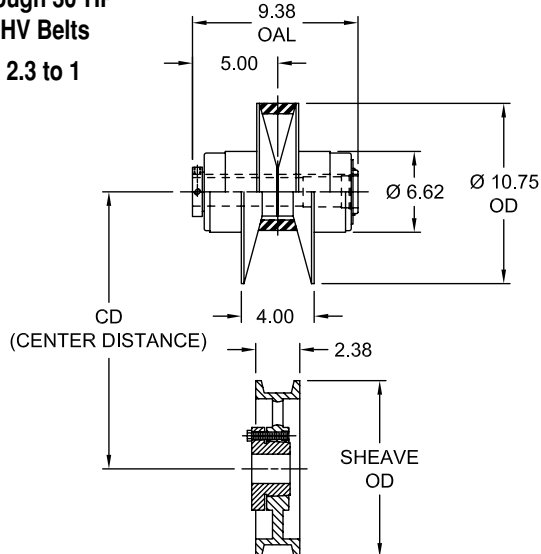

Model 23207 Spring-Loaded Driver Pulley

UPC Number	Bore in	PD		Torque Capacity in-lb	HP Rating	
		Min in	Max in		1750 RPM	1150 RPM
42448	1-1/8	4.43	10.35	in-lb	7-1/2	5
37346	1-3/8					
37347	1-5/8					

Model 23210 Spring-Loaded Driver Pulley

UPC Number	Bore in	PD		Torque Capacity in-lb	HP Rating	
		Min in	Max in		1750 RPM	1150 RPM
21930	1-3/8	4.43	10.35	360	10	7-1/2
21931	1-5/8					
27973	1-7/8					

Model 23220 Spring-Loaded Driver Pulley

UPC Number	Bore in	PD		Torque Capacity in-lb	HP Rating	
		Min in	Max in		1750 RPM	1150 RPM
27976	1-3/8	4.43	10.35	720	15 to 20	10 to 15
21948	1-5/8					
21949	1-7/8					

Model 23230 Spring-Loaded Driver Pulley

UPC Number	Bore in	PD		Torque Capacity in-lb	HP Rating	
		Min in	Max in		1750 RPM	1150 RPM
42457	1-3/8	4.43	10.35	1,080	25 to 30	20 to 25
21958	1-5/8					
21959	1-7/8					
42460	2-1/8					

23207 / 23210 / 23220 / 23230 Driven Sheave Selection Table

Grooved Driven Sheave			Driven Speed Range				Driven Torque			
UPC Number	Model	PD in	1750 RPM Motor		1150 RPM Motor		23207 in-lb	23210 in-lb	23220 in-lb	23230 in-lb
			Min RPM	Max RPM	Min RPM	Max RPM				
19586	3230G10.4SF	10.0	775	1,810	510	1,190	225	300	600	900
19588	3230G12.4SF	12.0	650	1,505	425	990	270	360	720	1,080
19590	3230G14.4SF	14.0	555	1,290	365	850	315	420	840	1,260
19592	3230G16.4SF	16.0	485	1,130	320	740	360	480	960	1,440
19594	3230G18.4SF	18.0	430	1,005	285	660	405	540	1,080	1,620

Horsepower Curves – 1,750 RPM Input

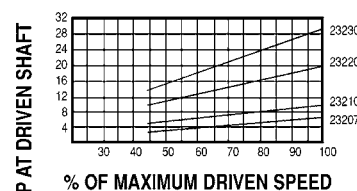

23207 / 23210 / 23220 / 23230 Belt Selection Table

UPC Number	Belt Size	Minimum Center Distance by Selected Sheave Size				
		3230G10.4SF	3230G12.4SF	3230G14.4SF	3230G16.4SF	3230G18.4SF
		in	in	in	in	in
23382	3230HV620	15.0	13.4	—	—	—
23384	3230HV670	17.5	15.9	14.3	—	—
23387	3230HV723	20.2	18.6	16.9	15.2	—
23389	3230HV821	25.1	23.5	21.8	20.2	18.4
23390	3230HV856	26.8	25.2	23.6	21.9	20.2
23392	3230HV931	30.6	29.0	27.4	25.7	24.0
23393	3230HV960	32.0	30.4	28.8	27.1	25.4

Note: ■ When referencing the Lovejoy UPC number in this table, include 685144 as a prefix to the number shown in the tables above.

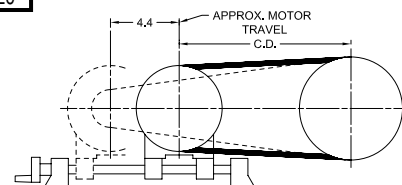

NEMA Frame Size	Recommended Motor Bases
213T, 215T	305-8, SMB 254
254T	310-30, SMB254
256T, 284T	310-30
286T, 324T	310-30



Variable Speed Drives

Hexadrive Models 24407, 24410, 24420 and 24430

Item Selection

Hexadrive Series

Two-Side Moveable
Adjustable Center Distance
5 through 30 HP
4430 V Belts
Ratio 2.7 to 1

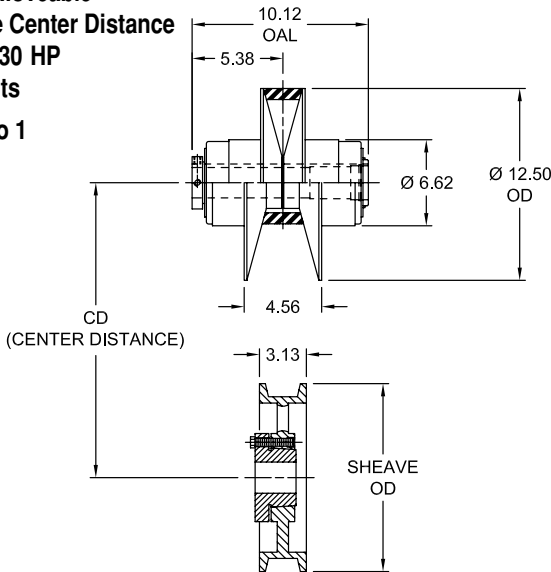

Horsepower Curves –
1,750 RPM Input

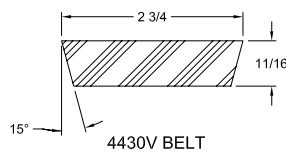
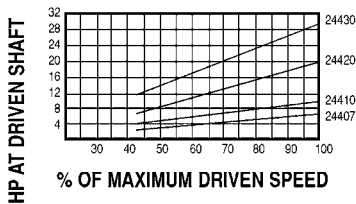

Model 24407 Spring-Loaded Driver Pulley

UPC Number	Bore in	PD		Torque Capacity in-lb	HP Rating	
		Min in	Max in		1750 RPM	1150 RPM
43059	1-1/8	4.43	12.10	270	7-1/2	5
37364	1-3/8					
37365	1-5/8					

Model 24410 Spring-Loaded Driver Pulley

UPC Number	Bore in	PD		Torque Capacity in-lb	HP Rating	
		Min in	Max in		1750 RPM	1150 RPM
22017	1-3/8	4.43	12.10	360	10	7-1/2
22018	1-5/8					
22019	1-7/8					

Model 24420 Spring-Loaded Driver Pulley

UPC Number	Bore in	PD		Torque Capacity in-lb	HP Rating	
		Min in	Max in		1750 RPM	1150 RPM
22042	1-3/8	4.43	12.10	720	15 to 20	10 to 15
22043	1-5/8					
22045	1-7/8					

Model 24430 Spring-Loaded Driver Pulley

UPC Number	Bore in	PD		Torque Capacity in-lb	HP Rating	
		Min in	Max in		1750 RPM	1150 RPM
27969	1-3/8	4.43	12.10	1,080	25 to 30	20 to 25
22054	1-5/8					
22055	1-7/8					
37354	2-1/8					

24407 / 24410 / 24420 / 24430 Driven Sheave Selection Table

Grooved Driven Sheave			Driven Speed Range				Driven Torque			
UPC Number	Model	PD in	1750 RPM Motor		1150 RPM Motor		24407 in-lb	24410 in-lb	24420 in-lb	24430 in-lb
			Min RPM	Max RPM	Min RPM	Max RPM				
19600	4430G10.4SF	10.0	775	2,115	510	1,390	225	300	600	900
19604	4430G12SK	11.6	670	1,825	440	1,200	260	348	696	1,044
63312	4430G14SF	13.6	570	1,555	375	1,020	306	408	716	1,224
19610	4430G16SK	15.6	500	1,355	330	890	350	468	936	1,404
19614	4430G18.4SF	18.0	435	1,175	285	770	405	540	1,080	1,620
19616	4430G20.4SF	20.0	390	1,055	255	695	450	600	1,200	1,800
19618	4430G24.4SF	24.0	325	880	215	580	540	720	1,440	2,160

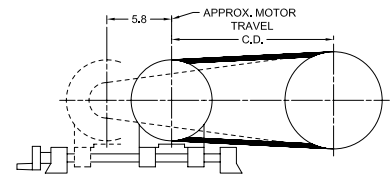

NEMA Motor Frame	Recommended Motor Bases
213T, 215T	305-8, SMB 254
254T	310-30, SMB254
256T, 284T	310-30
286T, 324T	310-30

24407 / 24410 / 24420 / 24430 Belt Selection Table

UPC Number	Belt Size	Minimum Center Distance by Selected Sheave Size						
		4430G10.4SK in	4430G12SK in	4430G14SK in	4430G16. SF in	4430G18.4SF in	4430G20.4SF in	4430G24.4SF in
23403	4430HV660	15.6	14.4	—	—	—	—	—
23407	4430HV718	18.5	17.3	15.7	—	—	—	—
23413	4430HV790	22.1	20.9	19.3	17.7	—	—	—
23414	4430HV850	25.1	23.9	22.3	20.7	18.7	—	—
23416	4430HV910	28.1	26.9	25.3	23.7	21.7	19.9	—
23418	4430HV970	31.1	29.9	28.3	26.7	24.7	23.0	19.4
23421	4430HV1030	34.1	32.9	31.3	29.7	27.7	26.0	22.5
23423	4430HV1090	37.1	35.9	34.3	32.7	30.7	29.0	25.5

Note: ■ When referencing the Lovejoy UPC number in this table, include 685144 as a prefix to the number shown in the tables above.

Hexadrive Series

Fixed Center Distance
 1/2 through 3/4 HP
 1422V Belts
 Ratio 7.5 to 1

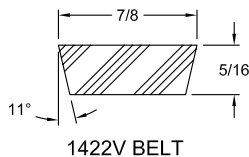
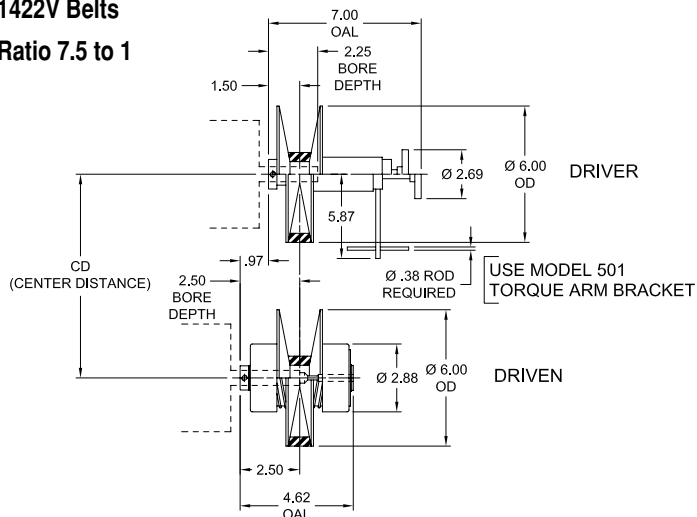

Model M-007 Adjustable Driver Pulley

UPC Number	Bore in	PD		HP Rating	
		Min in	Max in	1750 RPM	1150 RPM
31670	1/2	1.90	5.80	7-1/2	5
31671	5/8				
31672	3/4				

Model 21407 Spring-Loaded Driver Pulley ("C" or "Z" Mount)

UPC Number	Bore in	PD		Torque Capacity in-lb	HP Rating	
		Min in	Max in		1750 RPM	1150 RPM
21089	5/8	2.21	5.80	27	3/4	1/2
21090	3/4					
21091	7/8					

Horsepower Curves – 1,750 RPM Input

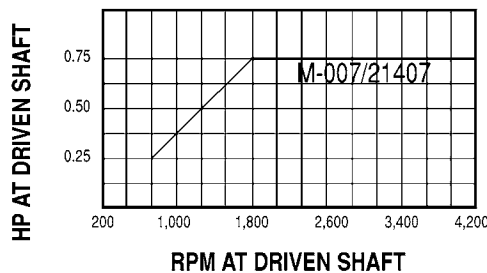

M-007 / 21407 Drives-Belt Selection and Driven Speeds

Center Distance & Belt Size			Driven Speed Range					
			1750 RPM Driver			1150 RPM Driver		
UPC Number	Belt Size	CD in	Min RPM	Max RPM	Ratio	Min RPM	Max RPM	Ratio
23255	1422V300	8.70	580	4,380	7.5 to 1	380	2,875	7.5 to 1
23257	1422V340	10.73						
23258	1422V360	11.74						
23259	1422V400	13.76	580	4,380	7.5 to 1	380	2,875	7.5 to 1
23260	1422V420	14.77						
23261	1422V460	16.79						
23262	1422V480	17.79	580	4,380	7.5 to 1	380	2,875	7.5 to 1
23263	1422V540	20.81						
23264	1422V600	23.82						
23265	1422V660	26.84	580	4380	7.5 to 1	380	2,875	7.5 to 1
23266	1422V720	29.85						
23267	1422V780	32.85						

Notes: ■ The belt sizes shown in this chart are based upon initial drive set-up with the adjustable pulley at minimum pitch diameter (open) and the spring-loaded pulley at maximum pitch diameter (closed). The driven speed ranges and the resulting ratios shown in this chart are derived from mathematical calculations based upon exact center distances, constant motor speeds and manufacturers' belt specifications. Actual results will differ due to variations in any of these factors.
 ■ When referencing the Lovejoy UPC number in this table, include 685144 as a prefix to the number shown in the tables above.



Variable Speed Drives

Hexadrive Models HM-3, Pulleys C and Z

Item Selection

Hexadrive Series

Fixed Center Distance
1 through 3 HP
1922V Belts

Ratio up to 8.8 to 1

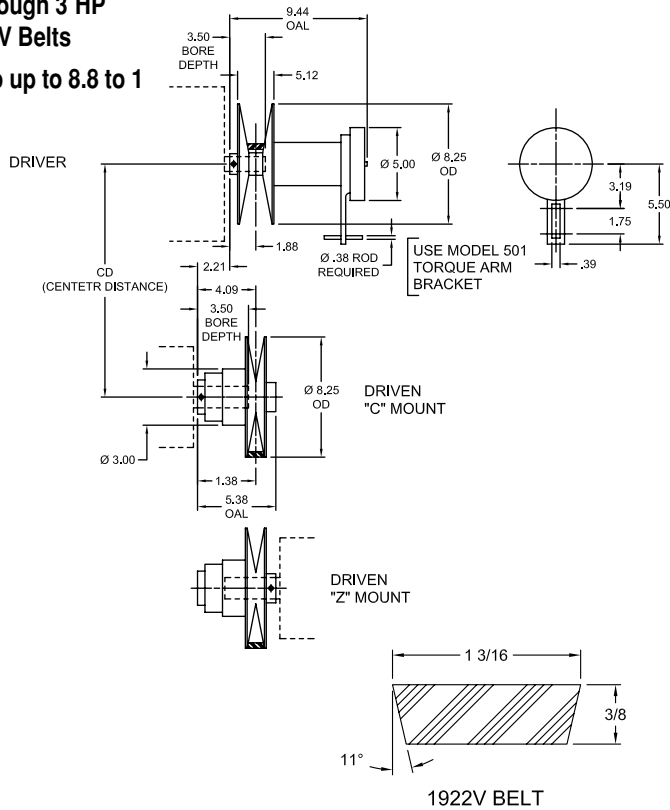

Model HM-3 Adjustable Driver Pulley

UPC Number	Bore in	PD		HP Rating	
		Min in	Max in	1750 RPM	1150 RPM
42595	3/4	2.70	8.03	1-1/2 to 5	1 to 2
21514	7/8				
21515	1				
21516	1-1/8				

Spring-Loaded Driven Pulleys for "C" Mounting

HP Rating		Torque Capacity in-lb	Model	PD		Stock Bore in
1750 RPM	1150 RPM			Min in	Max in	
1 to 1-1/2	3/4 to 1	54	31901	2.70	8.03	5/8, 3/4, 7/8
2 to 3	1-1/2 to 2	108	31902			1, 1-1/8

Spring-Loaded Driven Pulleys for "Z" Mounting

HP Rating		Torque Capacity in-lb	Model	PD		Stock Bore in
1750 RPM	1150 RPM			Min in	Max in	
1 to 1-1/2	3/4 to 1	54	11901	2.70	8.03	5/8, 3/4, 7/8
2 to 3	1-1/2 to 2	108	11902			1, 1-1/8

Horsepower Curves - 1,750 RPM Input

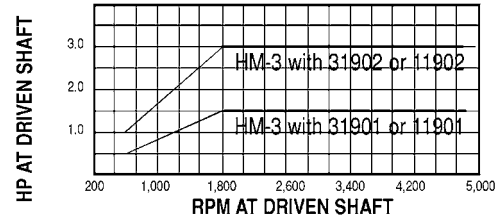

HM-3 Drives-Belt Selection and Driven Speeds Table

Center Distance & Belt Size			Driven Speed Range					
			1750 RPM Driver			1150 RPM Driver		
UPC Number	Belt Size	CD in	Min RPM	Max RPM	Ratio	Min RPM	Max RPM	Ratio
23280	1922V363	9.33	590	4,850	8.2 to 1	390	3,420	8.8 to 1
23281	1922V380	10.20						
23282	1922V403	11.37						
23283	1922V426	12.54						
23285	1922V443	13.40	590	4,850	8.2 to 1	390	3,420	8.8 to 1
23286	1922V454	13.96						
23287	1922V484	15.48						
23288	1922V526	17.60						
23290	1922V544	18.51	590	4,850	8.2 to 1	390	3,420	8.8 to 1
23292	1922V604	21.54						
23293	1922V646	23.65						
23294	1922V666	24.66						
23295	1922V686	25.66	590	4,850	8.2 to 1	390	3,420	8.8 to 1
23296	1922V706	26.67						
23299	1922V756	29.18						
23301	1922V846	33.70						

Notes: ■ The belt sizes shown in this chart are based upon initial drive set-up with the adjustable pulley at minimum pitch diameter (open) and the spring-loaded pulley at maximum pitch diameter (closed). The driven speed ranges and the resulting ratios shown in this chart are derived from mathematical calculations based upon exact center distances, constant motor speeds and manufacturers' belt specifications. Actual results will differ due to variations in any of these factors.

■ When referencing the Lovejoy UPC number in this table, include 685144 as a prefix to the number shown in the tables above.



Variable Speed Drives

Hexadrive Models HM-7, Pulleys C and Z

Item Selection

Hexadrive Series

Fixed Center Distance
3 through 7-1/2 HP
2926V Belts

Ratio up to 8.7 to 1

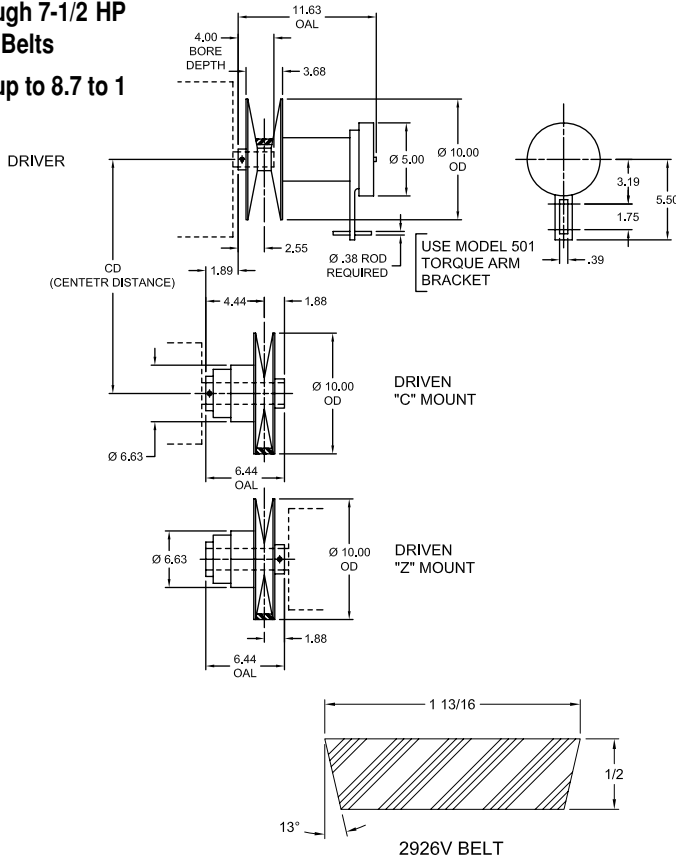

Model HM-7 Adjustable Driver Pulley

UPC Number	Bore in	PD		HP Rating	
		Min in	Max in	1750 RPM	1150 RPM
21541	1-1/8	3.28	9.70	5 to 7-1/2	3 to 5
21543	1-3/8				

Spring-Loaded Driven Pulleys for "C" Mounting

HP Rating		Torque Capacity in-lb	Model	PD		Stock Bore
1750 RPM	1150 RPM			Min in	Max in	
5	3	180	32904	3.28	9.70	1, 1-1/8
7-1/2	5	270	32905			1-3/8

Spring-Loaded Driven Pulleys for "Z" Mounting

HP Rating		Torque Capacity in-lb	Model	PD		Stock Bore
1750 RPM	1150 RPM			Min in	Max in	
5	3	180	12904	3.28	9.70	1, 1-1/8
7-1/2	5	270	12905			1-3/8

Horsepower Curves – 1,750 RPM Input

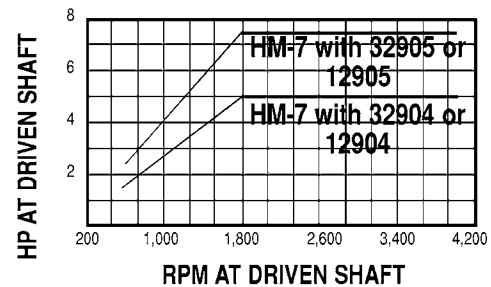

HM-7 Drives-Belt Selection and Driven Speeds Table

Center Distance & Belt Size			Driven Speed Range					
			1750 Driver			1150 Driver		
UPC Number	Belt Size	CD in	Min RPM	Max RPM	Ratio	Min RPM	Max RPM	Ratio
23346	2926V426	10.62	590	4,000	6.8 to 1	390	3,400	8.7 to 1
23350	2926V486	13.68						
23352	2926V521	15.46						
23353	2926V546	16.73						
23354	2926V574	18.15	590	4,000	6.8 to 1	390	3,400	8.7 to 1
23357	2926V616	19.76						
23360	2926V646	21.79						
23361	2926V666	22.80						
23362	2926V686	23.80	590	4,000	6.8 to 1	390	3,400	8.7 to 1
23364	2926V726	25.82						
23367	2926V786	28.84						
23368	2926V834	31.25						
23369	2926V856	32.36	590	4,000	6.8 to 1	390	3,400	8.7 to 1
23371	2926V906	34.88						
23372	2926V966	37.89						
23373	2926V1006	39.90						

Notes: ■ The belt sizes shown in this chart are based upon initial drive set-up with the adjustable pulley at minimum pitch diameter (open) and the spring-loaded pulley at maximum pitch diameter (closed). The driven speed ranges and the resulting ratios shown in this chart are derived from mathematical calculations based upon exact center distances, constant motor speeds and manufacturers' belt specifications. Actual results will differ due to variations in any of these factors.

■ When referencing the Lovejoy UPC number in this table, include 685144 as a prefix to the number shown in the tables above.



Variable Speed Drives

Hexadrive Models HM-30, Pulleys C and Z

Item Selection

Hexadrive Series

Fixed Center Distance
7-1/2 through 30 HP
4430V Belts

Ratio up to 7.4 to 1

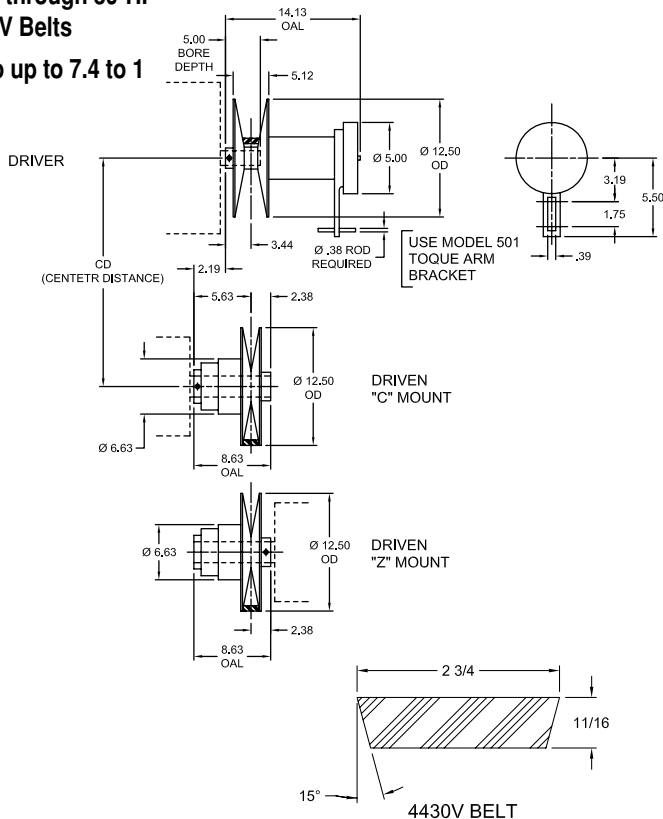

Model HM-30 Adjustable Driver Pulley

UPC Number	Bore in	PD		HP Rating	
		Min in	Max in	1750 RPM	1150 RPM
21616	1-3/8	4.43	12.10	10 to 30	7-1/2 to 20
21617	1-5/8				
21618	1-7/8				

Spring-Loaded Driven Pulleys for "C" Mounting

HP Rating		Torque Capacity in-lb	Model	PD		Stock Bore
1750 RPM	1150 RPM			Min in	Max in	
10	7-1/2	360	34407	4.43	12.10	1-3/8, 1-5/8
15	10	540				34410
20 to 30	15 to 20	1,080				34420

Spring-Loaded Driven Pulleys for "Z" Mounting

HP Rating		Torque Capacity in-lb	Model	PD		Stock Bore
1750 RPM	1150 RPM			Min in	Max in	
10	7-1/2	360	14407	4.43	12.10	1-3/8, 1-5/8
15	10	540				14410
20 to 30	15 to 20	1,080				14420

Horsepower Curves - 1,750 RPM Input

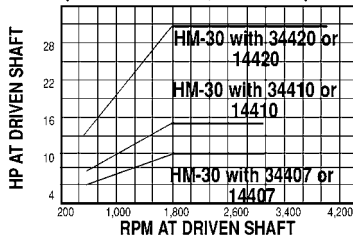

HM-30 Drives-Belt Selection and Driven Speeds Table

Center Distance & Belt Size			Driven Speed Range					
			1750 RPM Driver			1150 RPM Driver		
UPC Number	Belt Size	CD in	Min RPM	Max RPM	Ratio	Min RPM	Max RPM	Ratio
23396	4430V548	13.88	640	3,200	5.0 to 1	425	3,140	7.4 to 1
23397	4430V555	14.24						
23399	4430V578	15.41						
23400	4430V600	16.53						
23402	4430V630	18.05						
23403	4430V660	19.57	640	3,200	5.0 to 1	425	3,140	7.4 to 1
23405	4430V690	21.09						
23409	4430V730	23.11						
23411	4430V760	24.63						
23413	4430V790	26.15						
23414	4430V850	29.17	640	3,200	5.0 to 1	425	3,140	7.4 to 1
23416	4430V910	32.19						
23418	4430V970	35.21						
23421	4430V1030	38.23						
23423	4430V1090	41.25						
23426	4430V1150	44.26	640	3,200	5.0 to 1	425	3,140	7.4 to 1

Notes: ■ The belt sizes shown in this chart are based upon initial drive set-up with the adjustable pulley at minimum pitch diameter (open) and the spring-loaded pulley at maximum pitch diameter (closed). The driven speed ranges and the resulting ratios shown in this chart are derived from mathematical calculations based upon exact center distances, constant motor speeds and manufacturers' belt specifications. Actual results will differ due to variations in any of these factors.

■ When referencing the Lovejoy UPC number in this table, include 685144 as a prefix to the number shown in the tables above.

VSD

Hexadrive Series

Fixed Center Distance Adjustable Pulley Control Options

There are two additional variations of the standard "HM" Hexadrive adjustable pulley, giving the option of speed change by electric remote control or by using an external linear actuator. Either method offers convenience and safety in those situations where the pulley drive is inaccessible or in a hazardous location.

Hexact Electric Control Method

The Hexact Electric Control, or "HEC" pulley, operates in the same manner as the standard "HM" adjustable pulley, except the handwheel is replaced by a servo motor drive that opens and closes the pulley flanges. A separate control station, the Model CN-2601, is wired to the HEC pulley servo motor to provide speed adjustment from a remote location. The switch that is part of the CN-2601 control is a three-position toggle switch suitable for panel mounting. A wiring diagram is included, and the user must provide wires and a 110-volt power source for the servo motor. The CN-2601 Control must be ordered separately, and a Model 501 Torque Arm Bracket is also required.

All adjustable pulleys in our Hexadrive series, including the M-007, are available with the electric control option. When ordering, simply substitute HEC for M or HM. For example, the Model HM-3 manually adjustable pulley has the same drive characteristics as the Model HEC-3 electrically adjustable pulley. The only dimension differences are the overall length of the pulley and the torque arm.



HEC Adjustable Pulley

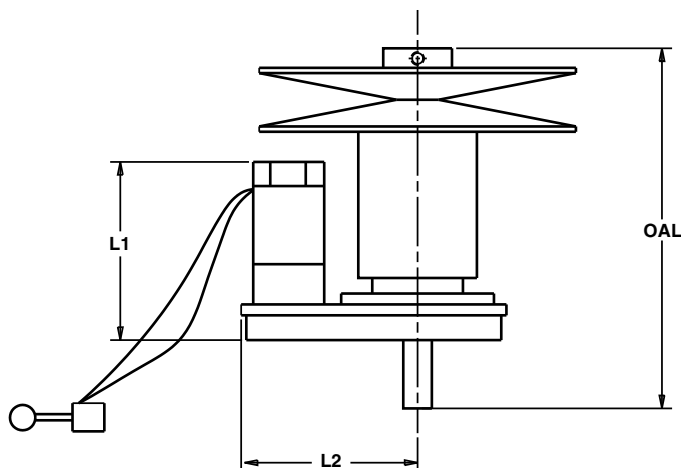

Interchange Selection Table

Manual Adjustable Pulley	HLA	HEC
	Adjustable Pulley	Adjustable Pulley
M-007	—	HEC-007
HM-3	HLA-3	HEC-3
HM-7	HLA-7	HEC-7
HM-30	HLA-30	HEC-30

HEC Pulley Dimension Data

HEC Adjustable	OAL in	L2 in	L1 in
HEC-007	7.00	6	4.75
HEC-3	8.75	6	4.75
HEC-7	11.56	6	5.25
HEC-30	13.75	6	7.25

VSD

Hexadrive Series

Hexact Linear Actuation Method

The HLA adjustable pulley can be used in place of the standard "HM" pulley where an external mechanical control is available. Typical control methods include hydraulic cylinder, air cylinder, and lever. The adapter nut located on the end of the HLA pulley will accept a threaded rod or a clevis with cross pins. The actuator linkage must be on the center line of the pulley, but radial freedom is required to relieve loads caused by misalignment of the linkage. Actuation rate (closing the moveable flange) should not exceed 2-1/2 inches per minute.

To specify the correct pulley, simply substitute the HLA prefix for the HM. For example, the Model HLA-7 pulley has the same drive characteristics as the Model HM-7 handwheel-type pulley. Refer to the adjacent chart for dimensional information. A torque arm bracket is NOT required for the HLA drive.



HLA Adjustable Pulley

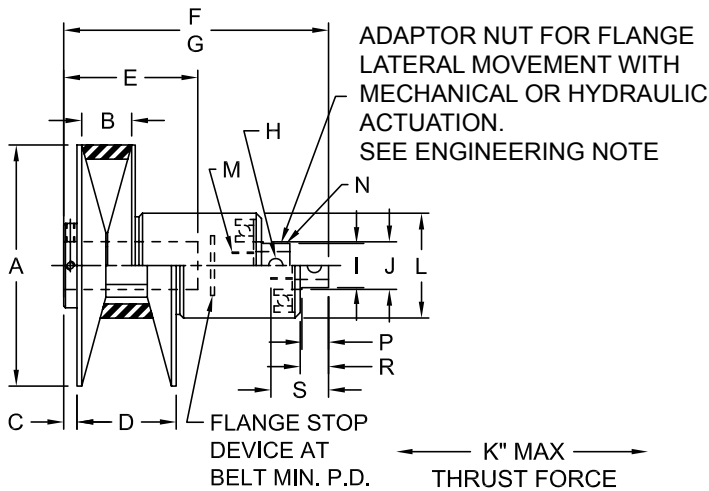

HLA Pulley Actuation Recommendations

Pulley Dimensional Data

Dimensons	HLA-3 in / lbs	HLA-7 in / lbs	HLA-30 in / lbs
"A" OD	8.25 in	10.00 in	12.50 in
"B" Belt Top Width	1.18 in	1.81 in	2.75 in
"C"	0.63 in	0.80 in	0.78 in
"D" @ Min. PD	2.52 in	3.59 in	5.19 in
"E" Bore Depth	3.5 in	6.00 in	7.5 in
"F" Max. Opening	8.37 in	10.17 in	12.83 in
"G" Min. Opening	7.31 in	8.75 in	10.81 in
"H" Thru Hole	0.39 in	0.39 in	0.39 in
"I" Across Flats	1.12 in	1.31 in	1.48 in
"J" Nut Dia	1.18 in	1.38 in	1.57 in
"K" Max. Thrust	472 lbs	765 lbs	1,015 lbs
"L" Dia.	3.00 in	3.75 in	4.5 in
"M" Thread	5/8 - 11 UNC	3/1 - 10 UNC	3/4 - 10 UNC
"N" Max. Depth	0.78 in Dia x 1.12 in	0.87 in Dia x 1.44 in	0.87 in Dia x 1.62 in
"P" Flat Length	0.75 in	1.00 in	1.00 in
"R"	1.00 in	1.25 in	1.12 in
"S" Max. Depth	2.00 in	2.50 in	3.00 in

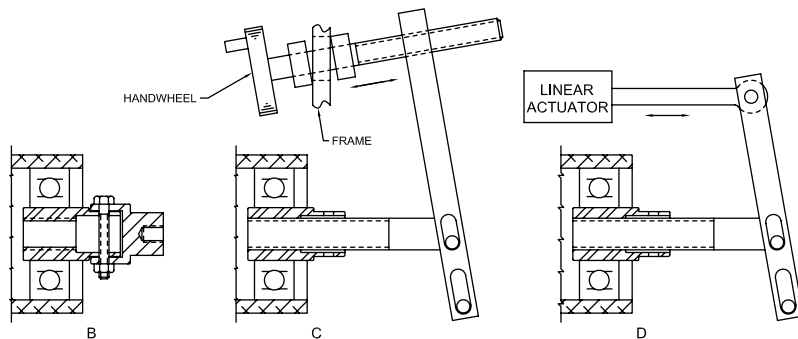

A-HYDRAULIC CYLINDER ACTUATION
 B-EXTENDED FEMALE COUPLER
 C-HANDWHEEL WITH ADJUSTABLE LEVER
 D-LINEAR ACTUATOR WITH ADJUSTABLE LEVER

Note: ■ To accommodate connection equipment misalignments all pivot points should have a loose fit.

Adjusta-Sheave Series

Variable Pitch Sheaves
5 through 30 HP
Wide Variable Speed Belts

The Lovejoy Adjusta-Sheave can be a cost-saving alternative to a spring-loaded pulley when speed change is infrequent, such as with seasonal or long-running applications. To change speeds the drive is shut down, the belt removed, and the pitch diameter is set by means of an internal adjusting screw. Set-up is simple because the nameplate has a dimension chart that relates the flange separation to the pitch diameter where the belt will be positioned.

The Adjusta-Sheave design incorporates features of the Hexadrive series, eliminating the need for internal drive keys, thus providing more efficient transfer of power and longer life.

Features

- Ratings ranging from 5 through 30 HP and speed ratios up to 2.5 to 1
- All models use wide variable speed belts
- No lubrication is required
- Belt alignment is maintained at all times due to the two moveable cast iron flanges

There are two methods of speed change with the Adjusta-Sheave: it can be used in place of the spring-loaded driver pulley, running to a fixed diameter companion sheave; or it can be used as the driven companion with a two-side moveable spring-loaded driver pulley. This second method actually increases the speed ratio of a drive package, because it can be broadened by changing the pitch diameter of the driven Adjusta-Sheave to extend the high and low speed limits. Both methods are adjustable center drives, requiring use of an adjustable motor base.



Adjusta-Sheave

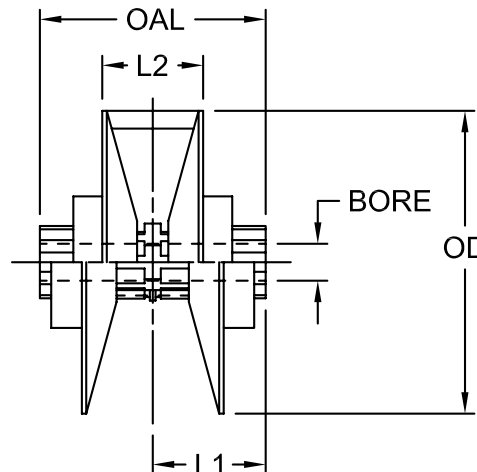
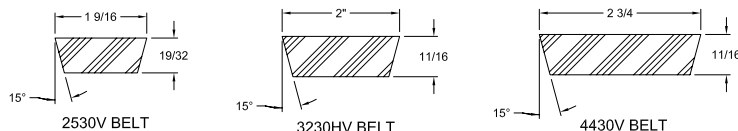

Adjusta-Sheave Variable Pitch Sleeves Inch Bore and Keyway Table

Model	Bore and Keyway			
	1-1/8 1/4 x 1/8	1-3/8 5/16 x 5/32	1-5/8 3/8 x 3/16	1-7/8 1/2 x 1/4
LAS25-10.25	27160	27161	27163	27164
LAS32-10.25	—	24165	27166	27167
LAS44-10.75	—	27168	27169	27170
LAS44-12.50	—	27171	27172	27173

Note: ■ When referencing the Lovejoy UPC number in this table, include 685144 as a prefix to the numbers shown.

Adjusta-Sheave Selection Guide and Dimension Table

Model	Recommended HP	Speed Ratio	PD		Belt Size	Stock Bores in	OAL in	L2 in	L1 in	OD in
			Max in	Min in						
LAS25-10.25	5-7-1/2	2:1	9.95	5.00	2530V	1-1/8, 1-3/8, 1-5/8, 1-7/8	5.38	3.28	2.69	10.25
LAS32-10.25	10-25	2.2:1	10.40	4.70	3230HV	1-3/8, 1-5/8, 1-7/8	7.37	4.00	3.68	10.75
LAS44-10.75	10-30	2.1:1	10.35	4.84	4430V	1-3/8, 1-5/8, 1-7/8	7.37	4.62	3.68	10.75
LAS44-12.50	10-30	2.5:1	12.10	4.84	4430V	1-3/8, 1-5/8, 1-7/8	7.37	5.06	3.68	12.50

Adjustable Motor Bases

Sliding and Tilting Bases

It is necessary to change the distance between the motor and driven shaft in order to change speed with an adjustable center drive. The best way to do this is with an adjustable motor base. Lovejoy offers four basic types of motor bases to satisfy requirements of space, convenience, interchangeability, motor frame size, and economy.

Sliding "SMB" Type

Models: SMB143, SMB184, and SMB254

SMB motor bases are extremely low profile and made of strong, lightweight steel, plated for protection against rust and corrosion. A folding knurled adjusting handle replaces the common round handwheel to offer easy speed adjustment with minimum effort and no tools. Adjustable maximum and minimum speed stops are included. The adjusting handle is easily removed for the addition of a sprocket or universal joint to adapt to existing control methods.

Features

- Three sizes available to fit NEMA motor frames from fractional through 15 horsepower
- Simple installation provided by a one-piece motor mounting plate
- Best possible belt alignment maintained because the motor shaft remains perpendicular to the plane of adjustment
- Slotted for standard NEMA motor frame mounting, but can be drilled for special mounting sizes to offer flexibility of design

For remote control in hazardous or inconvenient locations, Lovejoy offers electric servo motor controlled bases in the SMB style, both chain-driven (MRC) and direct coupled (ERC). Both types come complete with motor, control, and wiring diagram.

Sliding Cast Iron Type

Models: 135, 145-60, 301, 302-3, 403, 305-8 and 310-30

The original Lovejoy design, made of durable cast iron and steel.

Features

- Models are available to accommodate motors from fractional through 30 horsepower
- The independent, slotted motor mounting rails offer great flexibility of design, as they can be used to mount NEMA motor frames as well as IEC motors and other products (garmotors, gear reducers, etc.)
- Adjustable maximum and minimum speed stops are included

For remote control in hazardous or inconvenient locations, Lovejoy offers electric servo motor-controlled bases in some models of the cast iron bases, both direct coupled (ERC) and chain-driven (MRC). Also, stainless steel guide rods and adjusting screws are available on some models for severe environments or applications subject to washdown.

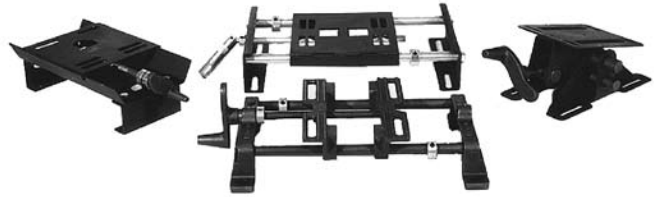

Adjustable Motor Bases

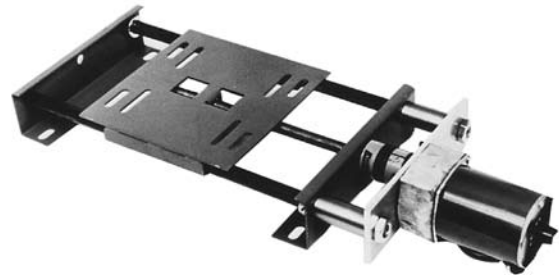

Direct Coupled Electric Servo Motor
Controlled Base – Type ERC

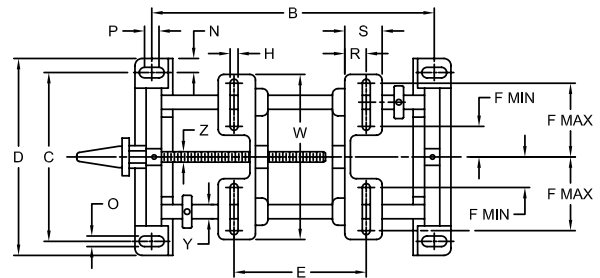

Sliding Cast Iron Base Upper View

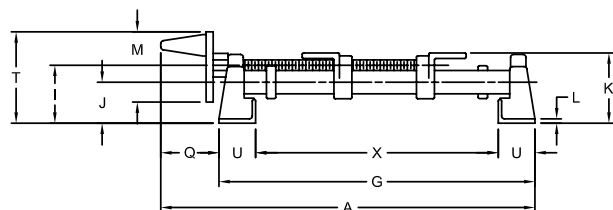

Sliding Cast Iron Base Side View

Adjustable Motor Base

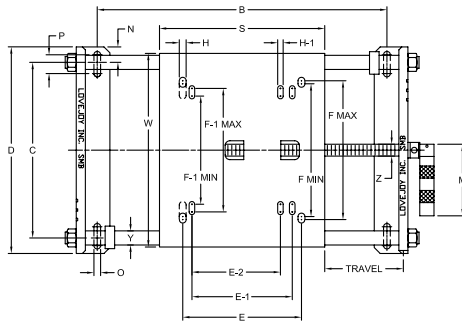

SMB (Steel) Base Upper View

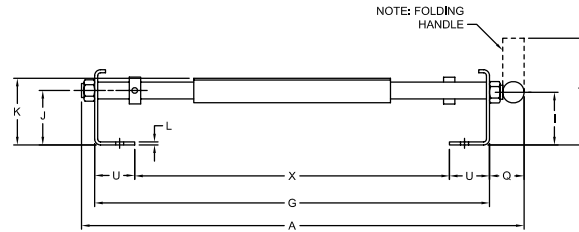

SMB (Steel) Base Side View

Sliding Cast Iron Bases (Drawing on page VSD-62)

Model	135	145-60	301	302-3	403	305-8	310-30
UPC Number	19714	19718	19763	19781	19902	19809	19816
A	13-1/4	16-1/8	18-1/2	19-3/8	21-3/8	27-7/8	31
B	9-7/8	12-5/8	15-1/8	16	18	23-5/8	25-1/4
C	6-1/8	7-7/8	8-1/2	8-1/2	8-1/2	11-7/8	14-1/4
D	7	8-3/4	10	10	10	14	15-1/2
E max	8	10	13	13-7/8	15-7/8	20	22
E min	2-1/8	2-3/4	3	3	3	4	5-3/8
F max	2-1/4	3-7/16	3-7/8	3-7/8	3-7/8	5-7/16	6-1/2
F min	13/16	1-5/16	1-7/8	1-7/8	1-7/8	2-5/8	2-7/8
G	11-1/8	13-7/8	16-3/8	17-1/4	19-1/4	25-1/4	27-3/8
H slot	3/8	13/32	13/32	13/32	13/32	9/16	5/8
I	1/16	2-1/2	3	3	3	4-1/4	4-1/4
J	3/8	1-3/4	2-1/8	2-1/8	2-1/8	2-7/8	3-3/4
K	2-1/2	3	3-1/2	3-1/2	3-1/2	5	6-1/4
L	5/16	3/8	3/8	3/8	3/8	1/2	3/4
M	2-1/2	4-1/8	4-1/8	4-1/8	4-1/8	6	6
N	7/16	7/16	3/4	3/4	3/4	1-1/16	5/8
O slot	3/8	13/32	1/2	1/2	1/2	1/2	3/4
P	3/8	9/32	1/2	1/2	1/2	3/4	3/4
Q	2-1/8	2-1/8	2-1/8	2-1/8	2-1/8	2-5/8	3-5/8
R	5/8	13/16	13/16	13/16	13/16	1-7/16	1-9/16
S	1-1/8	1-3/8	1-1/2	1-1/2	1-1/2	2-3/4	3-3/8
T	3-1/4	4-3/4	5	5	5	7-1/8	7-1/8
U	1-1/4	1-1/4	2	2	2	3	2-3/16
W	5-5/8	8	9-5/16	9-5/16	9-5/16	12-1/2	15
X	8-5/8	11-3/8	13-3/8	13-1/4	15-1/4	19-1/4	23
Y (dia)	1/2	5/8	7/8	7/8	7/8	1-1/4	1-5/8
Z (dia)	3/8	1/2	5/8	5/8	5/8	3/4	1

Note: ■ When referencing the Lovejoy UPC number in this table, include 685144 as a prefix to the numbers shown.

SMB Bases

Model	SMB 143	SMB 184	SMB 254
UPC Number	40212	40213	40214
A	15-3/4	19-1/2	28-5/8
B	12-5/8	15-1/6	23-5/8
C	6	7-1/4	10-3/8
D	8-3/4	10	14
E	5-1/2	7-1/2	10
E-1	4-1/4	5-1/2	8-1/2
E-2	—	—	7-1/2
F max	4-15/32	6-7/32	8-29/64
F min	1-21/32	3-3/4	7-61/64
F-1 max	—	6-5/16	7-1/4
F-1 min	—	2-9/16	5-3/8
G	13-7/8	17-3/8	26
H	—	13/32	9/16
H-1	13/32	11/32	7/16
I	1-7/8	2	2-1/8
J	1-15/16	2	2-1/4
K	2-1/2	2-5/8	3-7/32
L	7/64	9/64	3/16
M	3-1/2	3-1/2	4-1/2
N	1-3/8	1-3/8	1-13/16
O	13/32	13/32	33/64
P	1-7/8	1-3/4	2-1/2
Q	1-13/32	1-3/4	2-5/16
S	7	9	13
T	5-1/8	5-3/16	7-1/8
U	1-1/4	2	2-1/2
W	7-1/4	9	12-3/4
X	11-3/8	13-3/8	21
Y (dia)	5/8	3/4	1-1/4
Z (dia)	1/2-13	5/8-11	1-5
Travel	5-5/8	7	11-1/4

VSD

Motor Base Selection Guide

	200A, 200B	48/56	135	145-60	SMB 143	301, 302-3 403	SMB 184	305-8	SMB 254	310-30
NEMA Motor Frame Size	48	48	48	56	48, 56	143T, 145T	143T, 145T	184T, 213T	184T, 213T	215T, 254T
	56	56	56	143T	143T	182T, 184T	182T, 184T	215T	215T, 254T	256T, 284T 286T, 324T

Adjustable Motor Bases

Sliding Dovetail Type

Models: 48/56 LA and 48/56 LB

These are the most compact, lowest-priced sliding motor bases offered by Lovejoy.

Features

- Easy motor mounting and speed adjustment due to the one-piece top plate, which is slotted for NEMA 48 and 56 motor frames
- So cost efficient they can be used as belt tensioning bases
- Tough steel construction makes them exceptionally durable

The Model 48/56 LA comes with a convenient hexagon head adjusting screw for use with your adjustable or socket wrench for fast speed change, and has a profile height of only 1-1/2 inches. The Model 48/56 LB is equipped with a handwheel and riser blocks that make tool-free adjustment quick and easy.

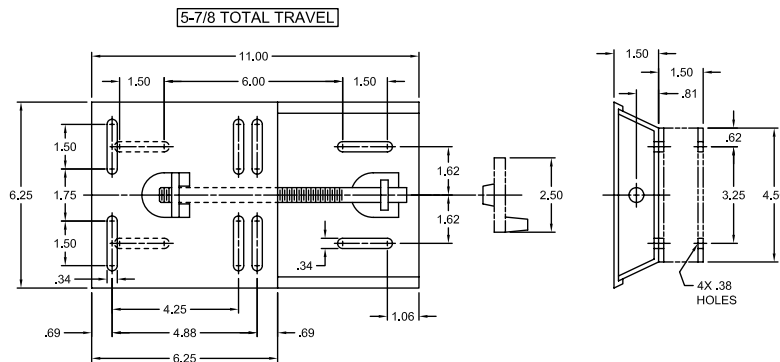

Model 48/56

Tilting Type

Models: 200A and 200B

These are economical bases featuring pivotal rather than sliding movement and are designed for use with NEMA 48 and 56 motor frames.

Features

- Less space is required to move the motor through the entire speed range because of the use of tilting motor rails
- Ideal for belt tensioning and for easy belt change with cone step pulleys
- Can be mounted in any position for added versatility

The Model 200A is made of cast iron with a steel adjusting mechanism, and the Model 200B has a stamped steel base and motor mounting rails. Overall dimensions and performance characteristics are the same for both models.

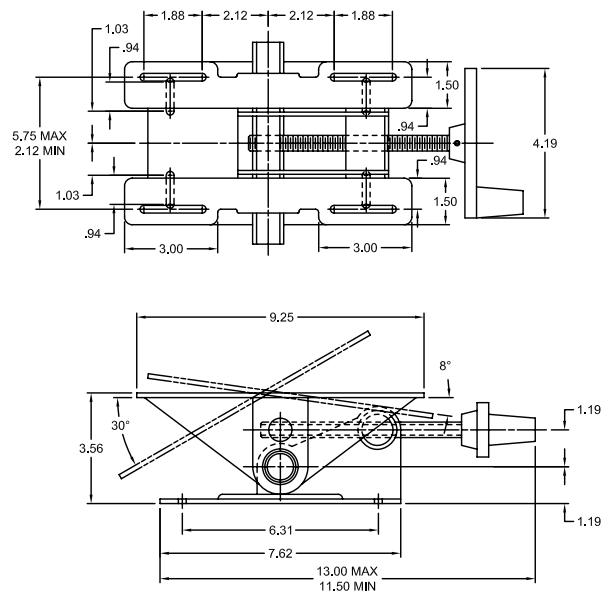

Model 200

VSD

Companion Sheaves

Flat and Grooved Types for Variable Speed Belts

Lovejoy companion sheaves are made of durable cast iron to assure best possible wear at the belt contact area. Grooved sheaves, for use with V-V adjustable center drives, are machined to match the belt width and angle of standard variable speed belts for optimum efficiency. The spoked design provides strength and light weight. All companion sheaves are

precision balanced for smooth running. The sheaves are bored to accept standard type tapered bushings for ease of installation, best possible shaft grip and removal from the shaft without damage to any of the parts.

Refer to page SF-17 for information on bushings.

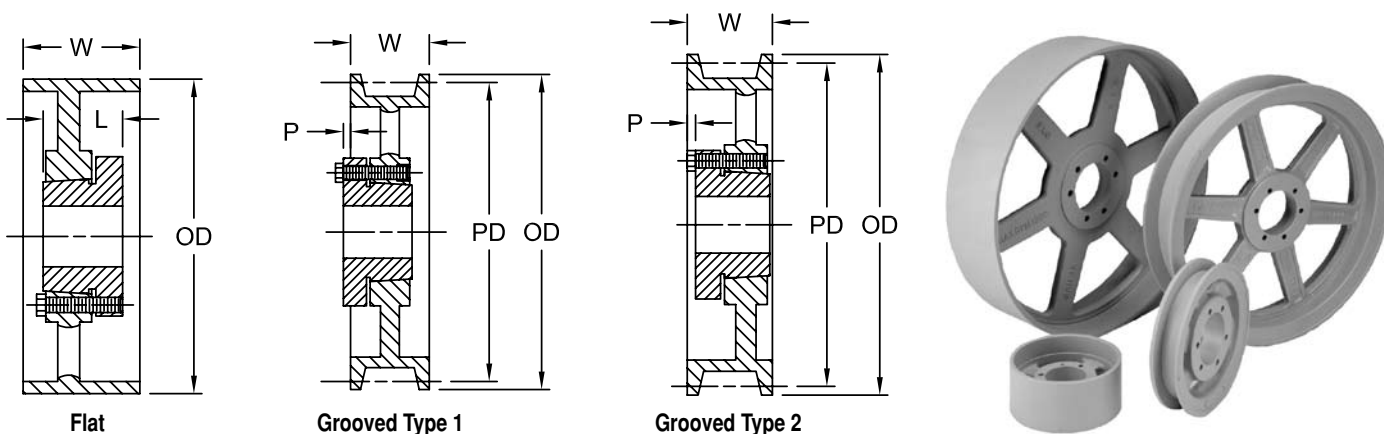

Flat Companion Sheave Dimensional Data

UPC Number	Model	W in	Bushing	L in	OD in	Weight lbs
19656	2.75F4SD	2.75	SD	1.81	4.0	4.0
19660	2.75F6SD	2.75	SD	1.81	6.0	6.0
19662	2.75F7SD	2.75	SD	1.81	7.0	7.0
19664	2.75F8SD	2.75	SD	1.81	8.0	8.0
19666	2.75F9SD	2.75	SD	1.81	9.0	9.0
19668	2.75F10SD	2.75	SD	1.81	10.0	13.0
19672	2.75F12SD	2.75	SD	1.81	12.0	18.0
19674	2.75F14SF	2.75	SF	2.06	14.0	20.0
19676	2.75F16SF	2.75	SF	2.06	16.0	22.0
19678	2.75F18SF	2.75	SF	2.06	18.0	27.0
19680	2.75F20SF	2.75	SF	2.06	20.0	30.0
19628	4.75F7SD	4.75	SD	1.81	7.0	8.0
19630	4.75F8SD	4.75	SD	1.81	8.0	10.5
19634	4.75F10SD	4.75	SD	1.81	10.0	16.0
19636	4.75F11SD	4.75	SD	1.81	11.0	16.0
19639	4.75F12SF	4.75	SF	2.06	12.0	28.0
19641	4.75F14SF	4.75	SF	2.06	14.0	32.0
19643	4.75F16SF	4.75	SF	2.06	16.0	28.0
19645	4.75F18SF	4.75	SF	2.06	18.0	34.0
19647	4.75F20SF	4.75	SF	2.06	20.0	35.0
19651	4.75F24SF	4.75	SF	2.06	24.0	50.0

Notes: ■ Sheave weights do not include bushing. Sheaves are suitable for operation at speeds up to 6,500 FPM.
 ■ When referencing the Lovejoy UPC number in this table, include 685144 as a prefix to the numbers shown.

VSD



Variable Speed Drives

Grooved Companion Sleeves

Dimensional Data

Dimensional drawings on page VSD-65.

Grooved Companion Sheaves Dimensional Data

Belt Series	Model	UPC Number	Bushing	W in	P in	OD in	PD in	Weight lbs	Type
1422V	1422G5.5SH	19493	SH	1.13	0.38	5.5	5.3	2.5	1
1422V	1422G6SH	19495	SH	1.13	0.38	6.0	5.8	2.5	1
1422V	1422G7SH	19497	SH	1.13	0.38	7.0	6.8	3.0	1
1422V	1422G8SH	19499	SH	1.13	0.38	8.0	7.8	4.0	1
1422V	1422G9SH	19501	SH	1.13	0.38	9.0	8.8	4.5	1
1422V	1422G10SH	19503	SH	1.13	0.38	11.0	9.8	5.0	1
1422V	1422G11SH	19507	SH	1.13	0.38	11.0	10.8	5.0	1
1422V	1422G12SH	19509	SH	1.13	0.38	12.0	11.8	6.0	1
1422V	1422G14SH	19511	SH	1.13	0.38	14.0	13.8	6.5	1
1922V	1922G7SK	19520	SK	1.69	0.44	7.0	6.8	8.0	1
1922V	1922G8SK	19522	SK	1.69	0.44	8.0	7.8	8.0	1
1922V	1922G9SK	19523	SK	1.69	0.44	9.0	8.8	9.0	1
1922V	1922G10SK	19524	SK	1.69	0.44	10.0	9.8	8.0	1
1922V	1922G12SK	19528	SK	1.69	0.44	12.0	11.8	12.0	1
1922V	1922G14SK	19529	SK	1.69	0.44	14.0	13.8	16.0	1
1922V	1922G16SK	19531	SK	1.69	0.44	16.0	15.8	17.5	1
2322V	2322G7SK	19538	SK	1.69	0.44	7.0	6.8	7.0	1
2322V	2322G8SK	19540	SK	1.69	0.44	8.0	7.8	7.0	1
2322V	2322G9SK	19544	SK	1.69	0.44	9.0	8.8	8.0	1
2322V	2322G10SK	19546	SK	1.69	0.44	10.0	9.8	8.0	1
2322V	2322G12SK	19548	SK	1.69	0.44	12.0	11.8	11.0	1
2322V	2322G14SK	19550	SK	1.69	0.44	14.0	13.8	14.0	1
2322V	2322G16SK	19553	SK	1.69	0.44	16.0	15.8	16.0	1
2926V	2926G8SK	19561	SK	2.13	0.19	8.0	7.7	8.0	1
2926V	2926G9SK	19563	SK	2.13	0.19	9.0	8.7	8.0	1
2926V	2926G10SK	19565	SK	2.13	0.19	10.0	9.7	10.5	1
2926V	2926G12SK	19567	SK	2.13	0.19	12.0	11.7	11.0	1
2926V	2926G14SK	19569	SK	2.13	0.19	14.0	13.7	13.5	1
2926V	2926G16SK	19572	SK	2.13	0.19	16.0	15.7	17.0	1
2926V	2926G18SK	43639	SK	2.13	0.19	18.0	17.7	30.5	1
3230HV	3230G8.4SF	49580	SF	2.38	0.06	8.4	8.0	14.0	1
3230HV	3230G9.4SF	19582	SF	2.38	0.06	9.4	9.0	14.0	1
3230HV	3230G9.6SF	19584	SF	2.38	0.06	9.6	9.2	14.0	1
3230HV	3230G9.9SF	19586	SF	2.38	0.06	9.9	9.5	16.0	1
3230HV	3230G10.4SF	19588	SF	2.38	0.13	10.4	10.0	22.0	1
3230HV	3230G12.4SF	19590	SF	2.38	0.13	12.4	12.0	27.0	1
3230HV	3230G14.4SF	19590	SF	2.38	0.13	14.4	14.0	34.0	1
3230HV	3230G16.4SF	19592	SF	2.38	0.13	16.4	16.0	39.0	1
3230HV	3230G18.4SF	19594	SF	2.38	0.13	18.4	18.0	45.0	1
3230HV	3230G20.4SF	19596	SF	2.38	0.13	20.4	20.0	47.0	1
4430V	4430G8.4SF	19598	SF	3.13	0.13	8.4	8.0	20.0	2
4430V	4430G10.4SF	19600	SF	3.13	0.13	10.4	10.0	22.0	2
4430V	4430G12SK	19604	SK	3.13	0.25	12.0	11.6	19.0	2
4430V	4430G14SF	63312	SF	3.13	0.25	14.0	13.6	23.0	2
4430V	4430G16SK	19610	SK	3.13	0.19	16.0	15.6	27.5	2
4430V	4430G18.4SF	19614	SF	3.13	0.19	18.4	18.0	51.5	2
4430V	4430G20.4SF	19616	SF	3.13	0.19	20.4	20.0	56.5	2
4430V	4430G24.4SF	19618	SF	3.13	0.19	24.4	24.0	67.5	2

Note: ■ When referencing the Lovejoy UPC number in this table, include 685144 as a prefix to the numbers shown.



Variable Speed Drives Belts Item Selection

Variable Speed Belts

7/8 through 2-3/4 inch Top Width

Lovejoy variable speed belts are designed for long life, even tracking, smooth running, and efficient transmission of power through wide speed ranges. They are made of special synthetic compounds to provide maximum service in conditions where oil, heat (up to 200° F), and static are present. Maximum recommended belt speed is 5,600 feet per minute.

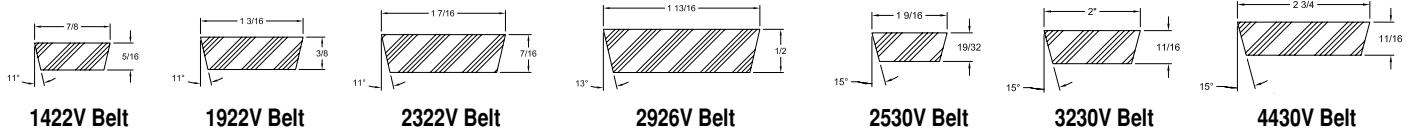

Variable Speed Belts UPC Number Selection Table

Belt Size	Pitch Length in	UPC Number	Belt Size	Pitch Length in	UPC Number	Belt Size	Pitch Length in	UPC Number
1422V300	30.0	23255	2322V364	36.4	23312	3230HV570	57.0	23379
1422V340	34.0	23257	2322V384	38.4	23314	3230HV585	58.5	23380
1422V360	36.0	23258	2322V421	42.1	23315	3230HV603	60.3	23381
1422V400	40.0	23259	2322V441	44.1	23317	3230HV620	62.0	23382
1422V420	42.0	23260	2322V481	48.1	23318	3230HV670	67.0	23384
1422V460	46.0	23261	2322V521	52.1	23319	3230HV685	68.5	23385
1422V480	48.0	23262	2322V541	54.1	23320	3230HV702	70.2	23386
1422V540	54.0	23263	2322V601	60.1	23322	3230HV723	72.3	23387
1422V600	60.0	23264	2322V621	62.1	23324	3230HV821	82.1	23389
1422V660	66.0	23265	2322V661	66.1	23326	3230HV856	85.6	23390
1422V720	72.0	23266	2322V681	68.1	23327	3230HV931	93.1	23392
1422V780	78.0	23267	2322V701	70.1	23328	3230HV960	96.0	23393
1922V321	32.1	23278	2322V721	72.1	23329	3230HV1060	106.0	38064
1922V363	36.3	23280	2322V801	80.1	23330	4430V548	54.8	23396
1922V380	38.0	23281	2322V826	82.6	23331	4430V555	55.5	23397
1922V403	40.3	23282	2322V886	88.6	23333	4430V578	57.8	23399
1922V426	42.6	23283	2322V1001	100.1	23335	4430V600	60.0	23400
1922V443	44.3	23285	2322V1271	127.1	23337	4430V630	63.0	23402
1922V454	45.4	23286	2926V426	42.6	23346	4430V660	66.0	23403
1922V484	48.4	23287	2926V486	48.6	23350	4430V690	69.0	23405
1922V526	52.6	23288	2926V491	49.1	23351	4430V718	71.8	23407
1922V544	54.4	23290	2926V521	52.1	23352	4430V730	73.0	23409
1922V604	60.4	23292	2926V546	54.6	23353	4430V760	76.0	23411
1922V646	64.6	23293	2926V574	57.4	23354	4430V790	79.0	23413
1922V666	66.6	23294	2926V586	58.6	23355	4430V850	85.0	23414
1922V686	68.6	23295	2926V606	60.6	23357	4430V910	91.0	23416
1922V706	70.6	23296	2926V616	61.6	23358	4430V970	97.0	23418
1922V726	72.6	23298	2926V646	64.6	23360	4430V1030	103.0	23421
1922V756	75.6	23299	2926V666	66.6	23361	4430V1090	109.0	23423
1922V806	80.6	23300	2926V686	68.6	23362	4430V1150	115.0	23426
1922V846	84.6	23301	2926V706	70.6	23363	4430V1320	132.0	23430
1922V966	96.6	23303	2926V726	72.6	23364	4430V1610	161.0	23434
			2926V776	77.6	23366			
			2926V786	78.6	23367			
			2926V834	83.4	23368			
			2926V856	85.6	23369			
			2926V906	90.6	23371			
			2926V966	96.6	23372			
			2926V1006	100.6	23373			
			2926V1086	108.6	23375			
			2926V1146	114.6	23376			

Note: ■ When referencing the Lovejoy UPC number in this table, include 685144 as a prefix to the numbers shown.



Pulley Service Factors

Service Factors For Variable Speed Pulleys

Duty	Description	Service Factor
Normal	Starting infrequent. Uniform load, not in excess of 110% of motor HP. Driven RPM within ranges in this catalog.	1.00
Moderately Heavy	Frequent starting: less than 15 minute intervals. Pulsating or light shock loads (not in excess of 125% of rated motor HP). High inertia of driven components such as large flywheels.	1.30
Heavy	Frequent reversing: less than 15 minute intervals or where rapid braking occurs. Heavy shock loads up to 150% of rated motor HP.	1.75

- Notes:
- The service factors will help in determining the horsepower of the drive, based on the power requirements at the driven shaft. Multiply the "actual" horsepower by the service factor to account for conditions such as described above. The selection of the variable speed pulley must match the final operating horsepower.
 - These Service Factors are designed to prevent belt slippage of more than 3%.

Useful Equations for Variable Speed Belt Drives

In All Equations, Unless Otherwise Noted:

d = Pitch Diameter of the driver pulley

D = Pitch Diameter of the driven pulley

N_d = RPM of driver pulley, "d"

N_D = RPM of driven pulley, "D"

1. RPM at driven pulley: $N_D = \frac{N_d \times d}{D}$

2. Pitch Diameter at driven: $D = \frac{N_d \times d}{N_D}$

3. Belt pull or net belt tension

permissible for each spring loaded pulley: $P = \frac{HP \times 126000}{N_d \times d}$

Where HP is the HP rating of the Variable Speed Pulley at N_d RPM and d is the maximum pitch diameter of the Variable Speed Pulley.

4. Torque and horsepower at driven pulley with the Variable Speed Pulley mounted on the driver shaft.

(Constant torque drive)

T = P x D/2, constant torque throughout speed range

$HP = \frac{T \times N_d}{63000}$ HP decreases in proportion to speed

5. Torque and horsepower at driven pulley with the Variable Speed Pulley mounted on the driven shaft.

(Constant horsepower)

T = P x D/2, torque decreases in proportion to D/2

$HP = \frac{T \times N_D}{63000}$ HP constant as T (torque) decreases, N_D (RPM of driven pulley) increases in proportion

6. Exact Belt length: $L = 2C + 1.57(D + d) + \frac{(D - d)^2}{4C}$

C = Center to center distance

7. Approximate Belt length: $L = 2C + 1.57(D + d)$

8. Center to Center distance: $C = \frac{L - [1.57(D + d) + (D - d)^2/L]}{2}$

9. Belt Speed: $FPM = \frac{N_D \pi D}{12}$ where N_D = RPM of pulley and D = diameter (in) at which belt is riding.

π = 3.14

FPM = feet per minute

10. Rim speed of pulley:

$V = \frac{N_D \pi D}{12}$ N_D = RPM of pulley and D = outside diameter of pulley
V = rim speed in feet per minute

Useful Information Regarding Pump & Fan Drives

VSD

Driven Equipment:

Displacement Pumps

Centrifugal Pumps, Fans, and Blowers

Horsepower for displacement and centrifugal pumps

$HP = \frac{\text{gallons per min} \times \text{head in feet}}{3960 \times \text{efficiency}}$

Horsepower for fans and blowers

$HP = \frac{\text{cu ft per min} \times \text{pressure (lb per sq ft)}}{33,000 \times \text{efficiency}}$

Effect of Speed on Horsepower:

HP varies in direct proportion to RPM.

HP varies as the cube of the speed (this would mean that a 10% increase in the speed of the pump would require 33% more HP).

1 cu ft per second = 448.8 GPM

1 lb per sq in pressure = a head of 2.309 ft for water weighing 62.36 lb per cu ft at 60° F.

Variable Speed Drive Interchange Guide

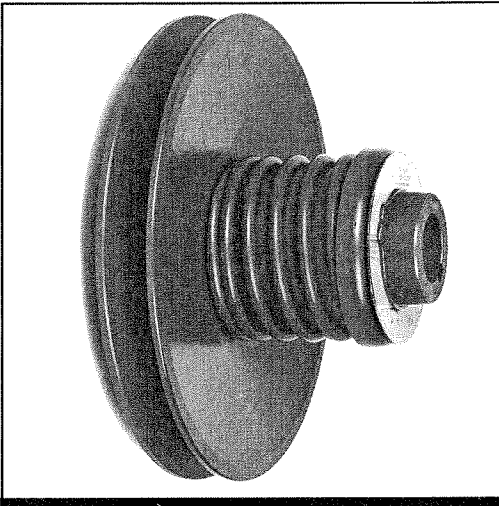

**COMPARED
WITH:**

BROWNING
GERBING
HI-LO
LEWELLEN
MAUREY
REEVES
SPEED SELECTOR
T.B. WOOD'S

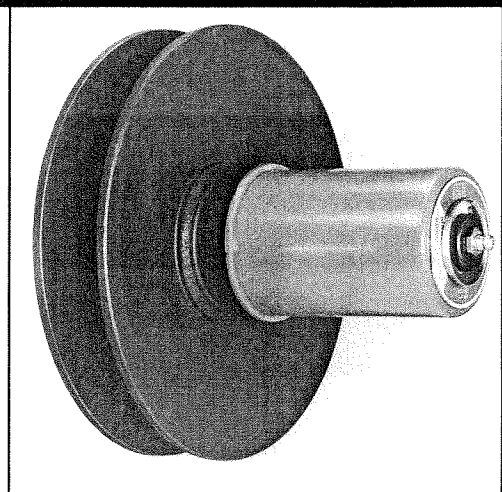

Lovejoy, Inc.
2655 Wisconsin Avenue
Downers Grove, IL 60515
Phone: 630-852-0500 Fax: 630-852-2120
www.lovejoy-inc.com

Variable Speed Pulley Interchange Guide

How to use this Interchange Guide

As the title implies, this is a *guide* to help you select the Lovejoy variable speed pulley most suitable for replacing a product made by one of the other major manufacturers. Unlike bearings and some other power transmission products, these are not always exact interchanges and there may be differences between the pulley you are replacing and the nearest Lovejoy equivalent. Sometimes this difference is insignificant and will not affect the performance of the drive package. For example, the Lovejoy pulley might be slightly shorter in overall length than the other brand, but it will still deliver the same torque and speed range with the same belt. At other times, the difference can be significant enough that the drive package will have to be re-positioned or other components will have to be changed in order to get the same results. For example, replacing a 13 inch diameter motor pulley with a similar pulley that is 12-1/2 inches in diameter will lower the highest available driven speed. There are other critical differences to be concerned with such as horsepower ratings, belt differences, and belt centerline (dimension "C" in the charts). **Please do not recommend any of these interchanges without checking all of the critical dimensions and data in the chart.** Failure to do so could result in unsatisfactory drive performance. If you're not sure, call Lovejoy's Engineering Department for assistance.

Table Of Contents

	Page
Browning Products	1
Gerbing Products	2-3
Hi-Lo Products	4-6
Lewellen Products	7
Maurey Products	7
Reeves Products	8
Speed Selector Products	9-12
T.B. Wood's Products	12-17

Variable Speed Pulley Interchange Guide

BROWNING

"MC" Series

Manually Adjustable Pulleys

MODEL NUMBER		BELT SIZE	*MAXIMUM RATIO	"A"
BROWNING	LOVEJOY			
3MC		4L(A)	3.1:1	3.00
		4L(A)	3.7:1	3.38
		4L(A)	3.7:1	3.38
4MC		4L(A)	3.3:1	4.00
		4L(A)	5.3:1	4.00
5MC		5L(B)	2.0:1	5.00
		5L(B)	7.6:1	5.00
		5L(B)	7.6:1	5.00
6MC		5L(B)	1.8:1	6.00
		5L(B)	5.8:1	6.00
		5L(B)	5.8:1	6.00

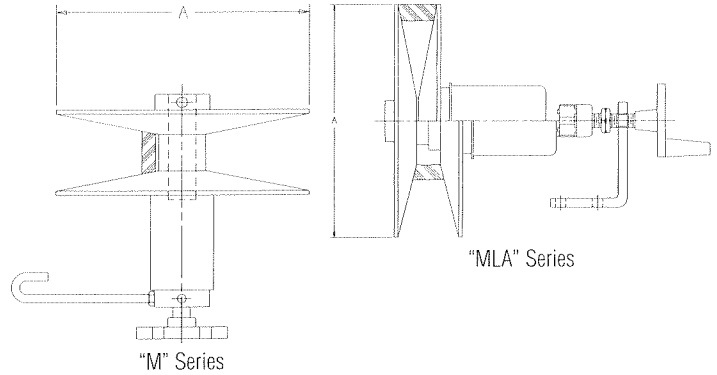

* Ratio will vary depending upon which companion spring-loaded pulley is being used.

BROWNING

"SL" Series

1-Side Moveable
Spring Loaded Pulleys

MODEL NUMBER		HP @ 1750 RPM	BELT SIZE	RATIO	"A"	"B"	"C"	"D"	"E"
BROWNING	LOVEJOY								
3SL		1/3	4L(A)	1.75:1	3.00	2.50	.91	.72	2.44
		3403	4L(A)	1.9:1	3.38	2.81	.94	.75	2.16
4SL		1/2	4L(A)	1.8:1	4.00	2.75	1.03	.78	2.94
		4005	4L(A)	2.3:1	4.00	2.81	.94	.75	2.16
5SL		1	5L(B)	1.5:1	5.00	3.94	1.03	.78	3.56
		5010	5L(B)	2.7:1	5.00	3.50	1.09	.81	2.50
6SL		1-1/2	5L(B)	1.4:1	6.00	3.94	1.03	.78	3.56
		6020	5L(B)	2.1:1	6.00	4.13	1.19	.95	3.13

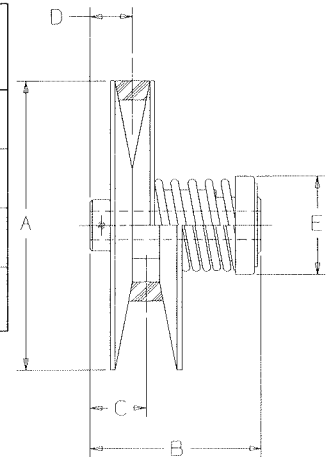

BROWNING

Wide Range Variable Speed Sheaves

MODEL NUMBER		BELT SIZE	P.D. RANGE		"A"	"B"	
BROWNING	LOVEJOY		MIN. P.D.	MAX. P.D.			
49R97		2530V	4.90	9.70	9.95	5.38	
		LAS 25-10.25	2530V	5.00	9.95	10.25	5.38
49W110		4430V	4.90	11.00	11.25	6.13	
		LAS 44-10.75	4430V	4.84	10.35	10.75	7.38
		LAS 44-12.50	4430V	4.84	12.10	12.50	7.38

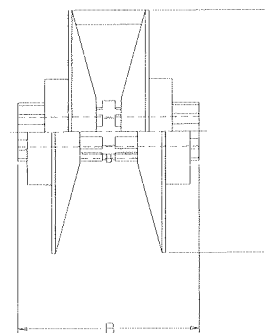

GERBING

"Roto-Cone" Series

2-Side Moveable
Spring Loaded Pulleys

MODEL NUMBER		HP @ 1750 RPM	BELT SIZE	RATIO	"A"	"B"	"C"	"D"
GERBING	LOVEJOY							
55		1/2	1422V	3.0:1	5.50	4.75	1.00	2.06
	245	1/2	1422V	3.0:1	6.00	4.86	1.31	2.25
60*		3/4	1922V	3.0:1	6.00	5.75	.94	2.25
	260*	3/4	1422V	3.0:1	6.00	4.86	1.31	2.25
75		1-1/2	1922V	3.0:1	7.50	7.13	1.25	2.63
	301E	1 to 1-1/2	1922V	3.0:1	7.50	7.13	1.56	2.50
80		3	2322V	3.0:1	8.00	8.00	1.44	2.87
	3030E	3	2322V	3.0:1	8.50	8.75	2.00	2.87
105		3	2926V	4.0:1	10.62	8.00	1.81	2.87
	403E	3	2926V	3.8:1	11.00	8.75	1.81	2.87
100		5	2926V	3.0:1	10.00	10.44	2.06	3.63
	3050E	5	2926V	3.0:1	10.00	10.31	2.13	3.19
125		7-1/2	4430V	3.0:1	12.50	11.50	2.13	4.25
	3075B	7-1/2	4430V	3.0:1	13.00	13.44	2.50	4.00
1307		7-1/2	4430V	3.0:1	13.00	12.56	2.25	4.50
	3075B	7-1/2	4430V	3.0:1	13.00	13.44	2.50	4.00
1310		10	4430V	3.0:1	13.00	12.56	2.25	4.50
	3100B	10	4430V	3.0:1	13.00	13.44	2.50	4.00
1315		15	4430V	3.0:1	13.00	12.56	2.25	4.50
	3150B	15	4430V	3.0:1	13.00	13.44	2.50	4.00

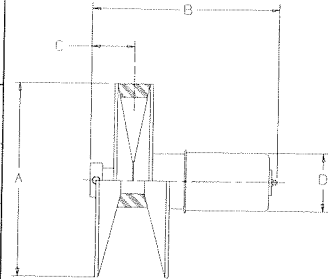

* Not an ideal interchange due to the difference in the belt width. For best performance, you should consider replacing the entire drive.

If any of the above Gerbing model numbers contain a "W" or "A" suffix, it is a manually adjustable pulley. These are not directly interchangeable with Lovejoy. The entire drive will need to be replaced. Call Lovejoy Engineering for assistance.

GERBING

"Var-A-Cone" Series

Manually Adjustable Pulleys

MODEL NUMBER		BELT SIZE	*MAXIMUM RATIO	"A"
GERBING	LOVEJOY			
30A		4L(A)	4.0:1	3.38
	MLA-34	4L(A)	3.6:1	3.38
	M-34	4L(A)	3.6:1	3.38
40A		4L(A)	5.6:1	4.00
	MLA-40	4L(A)	4.8:1	4.00
51A		5L(B)	7.5:1	5.00
	MLA-50	5L(B)	5.7:1	5.00
	M-50	5L(B)	5.7:1	5.00
57A		5L(B)	5.8:1	5.75
	MLA-60	5L(B)	4.7:1	6.00
	M-60	5L(B)	4.7:1	6.00

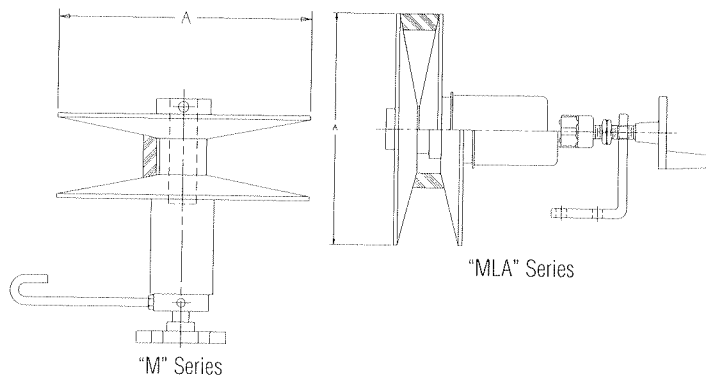

* Ratio will vary depending upon which companion spring-loaded pulley is being used.

See pg. 3 for the interchange of the companion "1-Side Moveable" Spring Loaded Pulleys.

Variable Speed Pulley Interchange Guide



GERBING

“Var-A-Cone” Series

1-Side Moveable
Spring Loaded Pulleys

MODEL NUMBER		HP @ 1750 RPM	BELT SIZE	RATIO	“A”	“B”	“C”	“D”	“E”
GERBING	LOVEJOY								
30		1/3	4L(A)	2.0:1	3.38	2.81	.94	.75	2.13
	3403	1/3	4L(A)	1.9:1	3.38	2.81	.94	.75	2.16
40		1/2	4L(A)	2.4:1	4.00	2.81	.94	.75	2.13
	4005	1/2	4L(A)	2.3:1	4.00	2.81	.94	.75	2.16
51		3/4	5L(B)	2.8:1	5.00	3.50	1.09	.81	2.13
	5010	1	5L(B)	2.7:1	5.00	3.50	1.09	.81	2.50
57		1-1/2	5L(B)	2.3:1	5.75	4.38	1.19	.95	2.25
	6020	2	5L(B)	2.1:1	6.00	4.13	1.19	.95	3.13

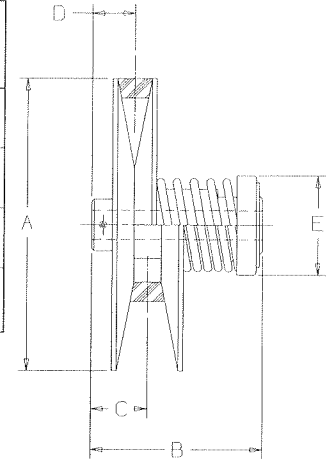

GERBING

“Quadra-Key” Series

2-Side Moveable
Spring Loaded Pulleys

MODEL NUMBER		HP @ 1750 RPM	BELT SIZE	RATIO	“A”	“B”	“C”	“D”
GERBING	LOVEJOY							
2303		3	2322V	3.0:1	9.05	5.75	2.88	5.40
	3030E ¹	3	2322V	3.0:1	8.50	8.75	2.00	2.87
2305*		5	2322V	3.0:1	9.05	5.75	2.88	5.40
	22905*	5	2926V	3.0:1	10.00	8.25	4.31	6.62
2905		5	2926V	3.0:1	10.50	7.48	3.74	5.40
	22905	5	2926V	3.0:1	10.00	8.25	4.31	6.62
2907		7-1/2	2926V	3.0:1	10.50	7.48	3.74	5.40
	22907	7-1/2	2926V	3.0:1	10.00	8.25	4.31	6.62
2910*		10	2926V	3.0:1	10.50	7.48	3.74	5.40
	23210*	10	3230HV	2.3:1	10.75	9.38	5.00	6.62
4410 (Alum)		10	4430V	3.0:1	13.00	9.60	4.80	6.67
4411 (CI)		10	4430V	3.0:1	13.00	9.60	4.80	6.67
	24410	10	4430V	2.7:1	12.50	10.13	5.38	6.62
4415 (Alum)		15	4430V	3.0:1	13.00	9.60	4.80	6.67
4416 (CI)		15	4430V	3.0:1	13.00	9.60	4.80	6.67
	24420	15 to 20	4430V	2.7:1	12.50	10.13	5.38	6.62
4420 (Alum)		20	4430V	3.0:1	13.00	9.60	4.80	6.67
4421 (CI)		20	4430V	3.0:1	13.00	9.60	4.80	6.67
	24420	15 to 20	4430V	2.7:1	12.50	10.13	5.38	6.62
4426		25	4430V	3.0:1	13.00	9.60	4.80	6.67
	24430	25 to 30	4430V	2.7:1	12.50	10.13	5.38	6.62
4431		30	4430V	3.0:1	13.00	9.60	4.80	6.67
	24430	25 to 30	4430V	2.7:1	12.50	10.13	5.38	6.62

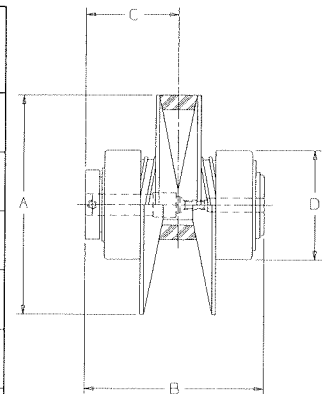

* Not an ideal interchange due to the difference in the belt width or angle. For best performance, you should consider replacing the entire drive.

(Alum) - Aluminum Flanges
(CI) - Cast Iron Flanges

¹ Requires sheave re-alignment.

HI-LO

"TBR" Series

1-Side Moveable
Spring Loaded Pulleys

MODEL NUMBER		HP @ 1750 RPM	BELT SIZE	RATIO	"A"	"B"	"C"	"D"	"E"
HI-LO	LOVEJOY								
30TBR	3407	3/4	4L(A)	2.0:1	3.38	2.69	.97	.78	3.06
		3/4	4L(A)	1.9:1	3.38	2.81	.94	.75	2.16
40TBR	4010	1	4L(A)	2.5:1	4.25	2.69	.97	.78	3.06
		1	4L(A)	2.3:1	4.00	2.81	.94	.75	2.16
50TBR	5015	1-1/2	5L(B)	2.7:1	5.00	3.06	1.01	.78	4.06
		1-1/2	5L(B)	2.7:1	5.00	3.50	1.09	.81	2.50
57-20TBR	6020	2	5L(B)	2.5:1	5.75	3.06	1.01	.78	4.06
		2	5L(B)	2.1:1	6.00	4.13	1.19	.95	3.13
57TBR	6030	3	5L(B)	2.5:1	5.75	3.88	1.33	1.09	5.07
		3	5L(B)	2.1:1	6.00	4.13	1.19	.95	3.13
66TBR	7050	5	5L(B)	2.0:1	6.63	3.88	1.33	1.09	5.07
		5	5L(B)	1.8:1	7.00	4.13	1.19	.95	3.13
86TBR	8250	5	5L(B)	1.6:1	8.63	3.88	1.33	1.09	5.07
		5	5L(B)	1.6:1	8.25	4.38	1.23	1.02	3.13

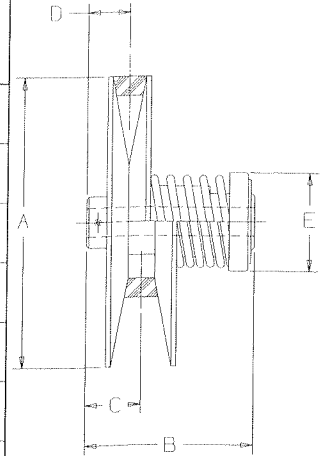

HI-LO

"DCW" Series

2-Side Moveable
Spring Loaded Pulleys

MODEL NUMBER		HP @ 1750 RPM	BELT SIZE	RATIO	"A"	"B"	"C"	"D"
HI-LO	LOVEJOY							
1160	21401	1 to 1-1/2	1422V	3.0:1	6.13	4.38	2.19	4.06
		1	1422V	2.6:1	6.00	4.63	2.50	2.88
1270	21903	3	1922V	3.0:1	7.50	5.88	2.87	5.07
		3	1922V	3.0:1	8.25	6.75	3.63	3.00
1590*	22905*	5	2322V	3.0:1	9.00	7.06	3.53	7.13
		5	2926V	3.0:1	10.00	8.25	4.31	6.63
1711*	23210*	10	3226V	3.0:1	11.00	8.66	4.33	7.13
		10	3230HV	2.3:1	10.75	9.38	5.00	6.63
2011	23220	20	3230HV	2.5:1	11.00	9.75	4.88	7.13
		15 to 20	3230HV	2.3:1	10.75	9.38	5.00	6.63
2513	24430	30	4430V	3.0:1	13.00	9.75	4.88	7.13
		25 to 30	4430V	2.7:1	12.50	10.13	5.38	6.63

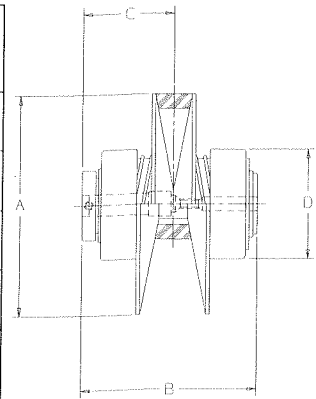

* Not an ideal interchange due to the difference in the belt width or angle. For best performance, you should consider replacing the entire drive.

HI-LO

"DCV" Series

2-Side Moveable
Spring Loaded Pulleys

MODEL NUMBER		HP @ 1750 RPM	BELT SIZE	RATIO	"A"	"B"	"C"	"D"
HI-LO	LOVEJOY							
140*		1	4L(A)	2.3:1	4.00	4.38	2.19	4.06
	2510*	1	5L(B)	2.5:1	5.00	4.06	2.18	2.67
150		1-1/2	5L(B)	2.5:1	5.00	4.38	2.19	4.06
	2515	1-1/2	5L(B)	2.3:1	5.00	4.06	2.18	2.67
157-20		2	5L(B)	2.2:1	5.75	4.38	2.19	4.06
	2620	2	5L(B)	2.1:1	6.00	5.06	2.53	3.13
157		3	5L(B)	2.2:1	5.75	4.94	2.50	5.07
	2630	3	5L(B)	2.1:1	6.00	5.06	2.53	3.13
167		5	5L(B)	2.5:1	6.88	5.88	2.88	5.07
	2750	5	5L(B)	1.8:1	7.00	5.06	2.53	3.13

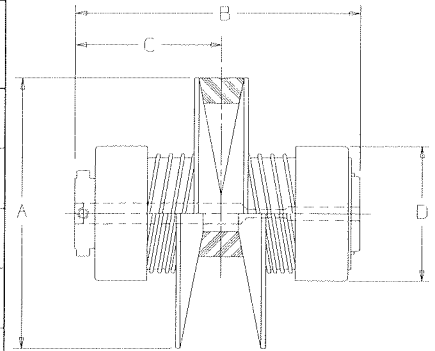

* Not an ideal interchange due to the difference in the belt width or angle. For best performance, you should consider replacing the entire drive.

Lovejoy Pulley Pledge Program

One of the keys of selling variable speed pulleys is product availability. Lovejoy has just made that job a little easier. Now, you are **guaranteed** the pulley required is available within 24 hours. The Lovejoy Pulley Pledge is simple but direct: each Lovejoy warehouse will be stocked with that region's most popular standard variable speed drive products as designated by a "+" in the Lovejoy Price Book or Lovejoy will ship your order next day air at no additional charge! Orders must be placed by 2:00 pm Central Time for one piece of a variable speed pulley, adjustable motor base or companion sheave. No more unnecessary downtime, no production delays because the pulley needed is out of stock. Please contact your local Lovejoy distributor or Lovejoy Customer Service for complete details.

HI-LO

"MCV" & "MCW" Series

Fixed Center Drives

DRIVER PULLEY MODEL NUMBER		DRIVEN PULLEY MODEL NUMBER		HP @ 1750 RPM (DRIVER)	BELT SIZE	DRIVEN SPEED RANGE (1750 RPM DRIVER)		"A" DRIVER O.D.	"B" DRIVEN O.D.	"C" OFFSET
HI-LO	LOVEJOY	HI-LO	LOVEJOY			MIN	MAX			
MCV30	M-34	30TBR	3405R	1/2	4L(A)	875	3500	3.38	3.38	.93
		40TBR		3/4	4L(A)	910	3380	3.38	3.38	1.12
			4007R	3/4	4L(A)	687	2106	3.38	4.25	.93
				3/4	4L(A)	760	2300	3.38	4.00	1.12
MCV500 MCV50	M-50	50TBR	5010R	1	5L(B)	647	4625	5.00	5.00	1.27
		57-20TBR		2	5L(B)	610	4640	5.00	5.00	1.62
		66TBR		2	5L(B)	557	3014	5.00	5.75	1.27
		7020R		2	5L(B)	500	2760	5.00	6.00	2.12
		86TBR		2	5L(B)	485	2248	5.00	6.62	1.77
			8220R	2	5L(B)	430	1940	5.00	7.00	2.12
				2	5L(B)	367	1408	5.00	8.62	1.77
				2	5L(B)	360	1440	5.00	8.25	2.30
MVC57	M-60	57TBR	6030R	3	5L(B)	648	4500	5.75	5.75	1.38
		66TBR		3	5L(B)	730	3500	6.00	6.00	1.95
		7030R		3	5L(B)	564	3214	5.75	6.62	1.38
		86TBR		3	5L(B)	620	2660	6.00	7.00	1.95
			8250R	5	5L(B)	427	1750	5.75	8.62	1.38
				5	5L(B)	520	1910	6.00	8.25	2.12
MCW600	M-14	60TBR	1401	1	1422V	550	5500	6.12	6.12	1.51
				1/2 to 1	1422V	430	3658	6.00	7.00	1.59
MCW600*	M-19*	75TBR*	1902*	1-1/2	1422V	400	3000	6.12	7.50	1.51
				1 to 2	1922V	403	4630	7.50	8.25	1.81
MCW70	M-19	80TBR	1902	2	1922V	423	4075	6.20	6.12	1.51
				1 to 2	1922V	403	4630	7.50	8.25	1.81
		90-19TBR		3	1922V	375	2863	6.20	9.00	1.51
			1903	3	1922V	403	4275	7.50	8.25	1.81
MCW77	M-19	90-19TBR	1903	3	1922V	450	3470	7.75	9.00	2.44
				3	1922V	403	4275	7.50	8.25	1.81
		110TBR		5	1922V	365	2108	7.75	11.00	2.44
	M-23*	2305*		5	2322V	346	4197	9.50	11.00	1.40
MCW90	M-23	90-23TBR	2303	3	2322V	450	4500	9.00	9.00	2.56
				3	2322V	346	4197	9.50	11.00	1.40
		106TBR	5	2322V	380	3420	9.00	10.60	2.56	
		2305	5	2322V	346	4197	9.50	11.00	1.40	
		120TBR		5	2322V	336	2490	9.00	12.00	2.56
		2305		5	2322V	346	4197	9.50	11.00	1.40
MCW-90-75*	HM-7*	120TBR*	32905*	7-1/2	2322V	336	2397	9.00	12.00	2.56
				7-1/2	2926V	590	4005	10.00	10.00	1.89

* Not an ideal interchange due to the difference in the belt width or angle. For best performance, you should consider replacing the entire drive.

These interchange suggestions are only to be used to replace a complete belt drive system. Do not attempt to replace just one part of the drive with a different manufacturer's pulley.

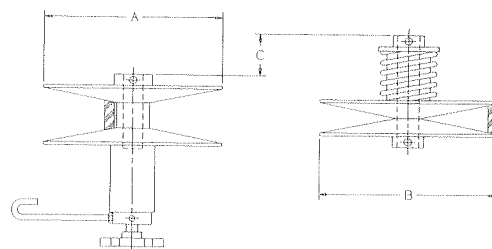

"M" Series

Variable Speed Pulley Interchange Guide



LEWELLEN

"400" Series

2-Side Moveable
Spring Loaded Pulleys

MODEL NUMBER		HP @ 1750 RPM	BELT SIZE	RATIO	"A"	"B"	"C"	"D"
LEWELLEN	LOVEJOY							
406		1/2 to 3/4	1422V	3.0:1	5.75	5.19	1.13	2.25
	245	1/2	1422V	3.0:1	6.00	4.86	1.31	2.25
	260	3/4	1422V	3.0:1	6.00	4.86	1.31	2.25
408		1 to 1-1/2	1922V	3.0:1	7.75	6.19	1.38	2.87
	301E	1 to 1-1/2	1922V	3.0:1	7.50	7.13	1.56	2.50
409		2 to 3	2322V	3.0:1	9.00	7.00	1.50	3.19
	3030E	3	2322V	3.0:1	8.50	8.75	2.00	2.87
411		2 to 3	2926V	4.0:1	11.00	8.13	1.75	3.19
	402E	2	2926V	3.8:1	11.00	8.75	1.81	2.87
	403E	3	2926V	3.8:1	11.00	8.75	1.81	2.87
410*		5	3230HV	3.0:1	10.00	8.56	1.87	3.75
	3050E*	5	2926V	3.0:1	10.00	10.31	2.13	3.19
410/B*		7-1/2	3230HV	3.0:1	10.00	8.56	1.87	3.75
	3050E-HD*	7-1/2	2926V	3.0:1	10.00	10.31	2.13	3.19
412		10	4430V	3.0:1	12.00	10.69	2.38	4.38
	3100B	10	4430V	3.0:1	13.00	13.44	2.50	4.00
412/15		15	4430V	3.0:1	12.00	10.69	2.38	4.38
	3150B	15	4430V	3.0:1	13.00	13.44	2.50	4.00

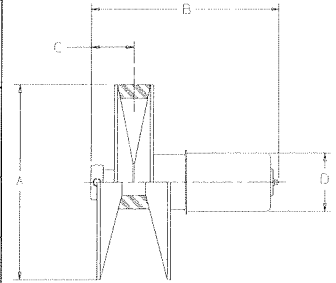

* Not an ideal interchange due to the difference in the belt width or angle. For best performance, you should consider replacing the entire drive.

MAUREY

"FHP" Series

1-Side Moveable
Spring Loaded Pulleys

MODEL NUMBER		HP @ 1750 RPM	BELT SIZE	RATIO	"A"	"B"	"C"	"D"	"E"
MAUREY	LOVEJOY								
6325		1/3	4L(A)	1.6:1	3.25	2.38	N/A	.72	2.31
	3403	1/3	4L(A)	1.9:1	3.38	2.81	.94	.75	2.16
6400		1/2	4L(A)	2.0:1	4.00	2.38	N/A	.72	2.31
	4005	1/2	4L(A)	2.3:1	4.00	2.81	.94	.75	2.16
6500		3/4 to 1	5L(B)	2.0:1	5.00	3.62	N/A	.96	3.18
	5010	1	5L(B)	2.7:1	5.00	3.50	1.09	.81	2.50
6600		1	5L(B)	2.1:1	6.00	3.88	N/A	.96	3.18
	6010	1	5L(B)	2.1:1	6.00	4.13	1.19	.95	3.13
66150		1-1/2	5L(B)	2.1:1	6.00	3.88	N/A	.96	3.18
	6020	2	5L(B)	2.1:1	6.00	4.13	1.19	.95	3.13
66200		2	5L(B)	2.1:1	6.00	3.88	N/A	.96	3.18
	6020	2	5L(B)	2.1:1	6.00	4.13	1.19	.95	3.13

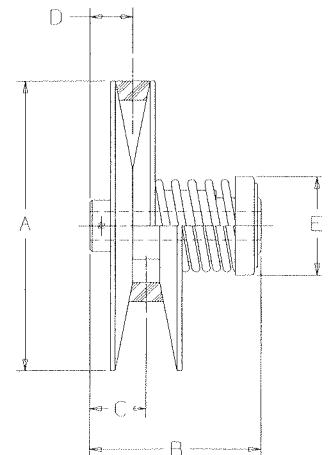

REEVES

"Sr. Pulley" Series

1-Side Moveable
Spring Loaded Pulleys

MODEL NUMBER		HP @ 1750 RPM	BELT SIZE	RATIO	"A"	"B"	"C"	"D"	"E"
REEVES	LOVEJOY								
5675		3/4	1422V	3.0:1	5.44	5.12	N/A	N/A	2.44
	11407	3/4	1422V	2.6:1	6.00	3.56	1.38	1.00	2.88
7202		1 to 2	1922V	3.0:1	7.01	6.04	N/A	N/A	3.13
	11902	2	1922V	3.0:1	8.25	5.38	1.88	1.38	3.00
9205		3 to 5	2926V	3.0:1	8.96	7.75	N/A	N/A	3.69
	12905	5	2926V	3.0:1	10.00	6.44	2.62	1.88	6.63
1110		7-1/2 to 10	4430V	3.0:1	11.09	10.08	N/A	N/A	5.00
	14410	10	4430V	2.7:1	12.50	8.62	3.44	2.38	6.63
912-15		15	4430V	2.0:1	12.00	11.31	N/A	N/A	4.28
	14420	15 to 20	4430V	2.7:1	12.50	8.62	3.44	2.38	6.63

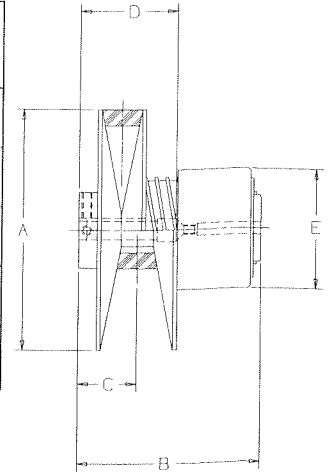

REEVES

"Jr. Pulley" Series

1-Side Moveable
Spring Loaded Pulleys

MODEL NUMBER		HP @ 1750 RPM	BELT SIZE	RATIO	"A"	"B"	"C"	"D"	"E"
REEVES	LOVEJOY								
830		1/4 to 1/3	4L(A)	1.7:1	3.75	3.69	N/A	N/A	2.16
	3403	1/4 to 1/3	4L(A)	1.9:1	3.38	2.81	.94	.75	2.16
850		1/2	4L(A)	2.2:1	5.13	4.97	N/A	N/A	2.16
	5005A	1/2	4L(A)	1.8:1	5.00	3.50	.92	.75	2.50
860		3/4	4L(A)	2.7:1	6.16	5.88	N/A	N/A	2.16
	170*	3/4	4L(A)	2.5:1	6.31	7.13	1.63	1.63	2.50
	5010A	3/4 to 1	4L(A)	1.8:1	5.00	3.50	.92	.75	2.50
870		1	5L(B)	2.5:1	7.16	6.88	N/A	N/A	2.78
	7010	1	5L(B)	1.8:1	7.00	4.13	1.19	.95	3.13
875		1-1/2	5L(B)	2.5:1	7.66	7.09	N/A	N/A	2.78
	180*	1-1/2	5L(B)	2.5:1	6.31	7.13	1.63	1.63	2.50
	7020	2	5L(B)	1.8:1	7.00	4.13	1.19	.95	3.13
	8220	2	5L(B)	1.6:1	8.25	4.38	1.23	1.02	3.13

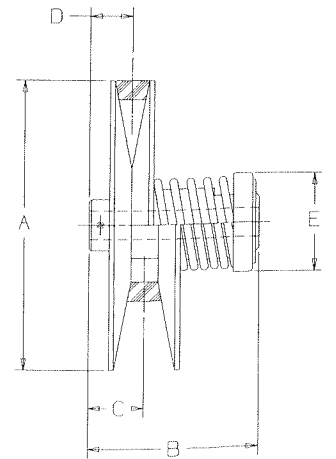

* These pulley models are 2-side moveable aluminum construction

SPEED SELECTOR

"Series 21"

Fixed Center Drives

DRIVER PULLEY MODEL NUMBER		DRIVEN PULLEY MODEL NUMBER		HP @ 1750 RPM (DRIVER)	BELT SIZE	DRIVEN SPEED RANGE (1750 RPM DRIVER)		"A" DRIVER O.D.	"B" DRIVEN O.D.	"C" OFFSET
SPEED SELECTOR	LOVEJOY	SPEED SELECTOR	LOVEJOY			MIN	MAX			
3C	MLA/M-34*	3M	3403R			1/4	4L(A)			
		4M	4005R	1/3	4L(A)	910	3380	3.38	3.38	1.12
				1/4	4L(A)	789	2152	3.12	4.00	.53
4C	MLA-40*	4M	4005R	1/2	4L(A)	760	2300	3.38	4.00	1.12
				1/2	4L(A)	875	3500	4.00	4.00	.50
5C	MLA/M-50*	5M	5010R	3/4	4L(A)	715	4290	5.00	5.00	.56
				1	5L(B)	610	4640	5.00	5.00	1.62
		6M	6010R	3/4	4L(A)	585	2710	5.00	6.00	1.00
				1	5L(B)	500	2760	5.00	6.00	2.12
		7M	7010R	3/4	4L(A)	535	2130	5.00	7.00	1.38
1	5L(B)			430	1940	5.00	7.00	2.12		
6C	MLA/M-60*	6M	6010R	3/4	4L(A)	455	1595	5.00	8.12	2.38
				1	5L(B)	360	1440	5.00	8.25	2.30
		7M	7010R	1	4L(A)	685	4650	6.00	6.00	.81
				1	5L(B)	730	3500	6.00	6.00	1.95
8-1-M	8210R	1	4L(A)	630	3160	6.00	7.00	1.19		
		1	5L(B)	620	2660	6.00	7.00	1.95		
7C	MLA/M-70*	7M	7020R	1	4L(A)	535	2310	6.00	8.12	2.00
				1	5L(B)	520	1910	6.00	8.25	2.12
		8-1-M	8220R	2	5L(B)	685	4450	7.00	7.00	.88
				2	5L(B)	880	3020	7.00	7.00	1.95
8-1-C	MLA/M-70*	8-1-M	8250R	2	5L(B)	608	3040	7.00	8.12	1.88
				2	5L(B)	750	2360	7.00	8.25	2.12
8-1-C	MLA/M-70*	8-1-M	8250R	5	5L(B)	645	4820	8.12	8.12	1.56
				5	5L(B)	750	2360	7.00	8.25	2.13

* The Lovejoy "MLA" Series Pulleys require a Lovejoy #76 Control Stand to actuate the pulley. The "M" Series Pulleys have a built in adjusting screw and handwheel for speed adjustment.

These interchange suggestions are only to be used to replace a complete belt drive system. Do not attempt to replace just one part of the drive with a different manufacturer's pulley.

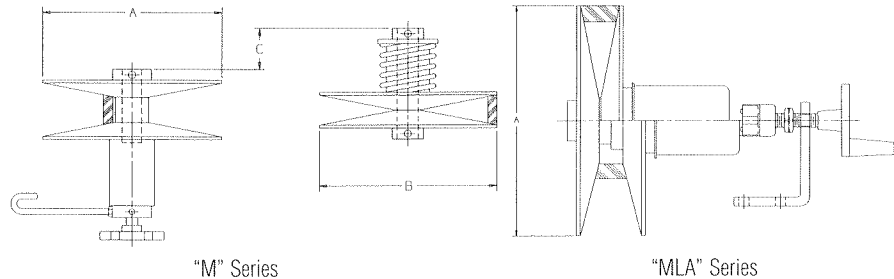

SPEED SELECTOR

"Series 21"

Adjustable Center Drives
Spring Loaded Pulleys

MODEL NUMBER		1750 RPM	HP @ BELT SIZE	RATIO	"A"	"B"	"C" MIN. P.D.	"D" MAX. P.D.	"E"
SPEED SELECTOR	LOVEJOY								
3M	3402	1/4	4L(A)	2.0:1	3.12	2.44	1.50	1.65	1.25
		1/4	4L(A)	1.9:1	3.38	2.81	.94	.75	2.16
4M	4005	1/2	4L(A)	2.0:1	4.00	2.25	1.28	1.44	1.68
		1/2	4L(A)	2.3:1	4.00	2.81	.94	.75	2.16
5M	5010A	3/4	4L(A)	2.5:1	5.00	3.62	1.38	1.68	1.68
		1	4L(A)	1.8:1	5.00	3.50	.92	.75	2.50
6M	6020	1-1/2	4L(A)	2.6:1	6.00	4.68	1.75	2.13	2.25
		1-1/2 to 2	5L(B)	2.1:1	6.00	4.13	1.19	.95	3.13
7M	7020	2	5L(B)	2.8:1	7.00	4.65	2.00	2.53	2.38
		2	5L(B)	1.8:1	7.00	4.13	1.19	.95	3.13
8-1-M	8250	5	5L(B)	2.8:1	8.12	6.44	2.62	3.31	2.88
		5	5L(B)	1.6:1	8.25	4.38	1.23	1.02	3.13

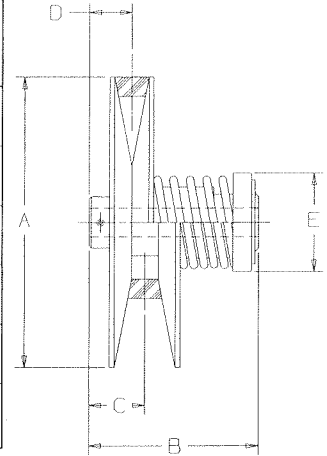

SPEED SELECTOR

"Series 800"

1-Side Moveable
Spring Loaded Pulleys

MODEL NUMBER		HP @ 1750 RPM	BELT SIZE	RATIO	"A"	"B"	"C"	"D"	"E"
SPEED SELECTOR	LOVEJOY								
816	11407 11401	1/2 to 1	1422V	3.0:1	6.50	4.38	1.90	1.53	4.18
		1/2 to 3/4	1422V	2.6:1	6.00	3.56	1.38	1.00	2.87
		1	1422V	2.6:1	6.00	3.56	1.38	1.00	2.87
827	11901 11902 11903	1-1/2 to 3	1922V	3.0:1	7.75	5.25	1.80	1.31	4.62
		1-1/2	1922V	3.0:1	8.25	5.38	1.87	1.38	3.00
		2	1922V	3.0:1	8.25	5.38	1.87	1.38	3.00
		3	1922V	3.0:1	8.25	5.38	1.87	1.38	3.00
859	3030D 12905*	3 to 5	2322V	3.0:1	9.50	6.50	1.90	1.31	5.87
		3	2322V	3.0:1	8.50	8.75	1.81	1.18	2.87
		5	2926V	3.0:1	10.00	6.44	2.62	1.87	6.62
810*	13207* 13210*	7-1/2 to 10	3226V	3.0:1	10.50	7.94	2.31	1.53	7.00
		7-1/2	3230HV	2.3:1	10.75	7.88	3.00	2.25	6.62
		10	3230HV	2.3:1	10.75	7.88	3.00	2.25	6.62
821	14420	15 to 20	4430V	3.0:1	12.00	9.03	3.09	2.06	7.00
		15 to 20	4430V	2.7:1	12.50	8.62	3.44	2.38	6.62
833	14430	25 to 30	4430V	3.0:1	13.00	9.34	2.97	1.84	6.94
		25 to 30	4430V	2.7:1	12.50	8.62	3.44	2.38	6.62

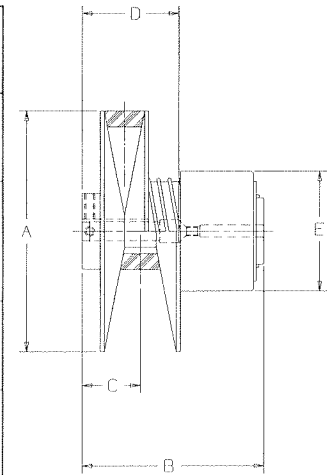

* Not an ideal interchange due to the difference in the belt width or angle. For best performance, you should consider replacing the entire drive.

Variable Speed Pulley Interchange Guide



SPEED SELECTOR

“Series 8800”

2-Side Moveable

Spring Loaded Pulleys

MODEL NUMBER		HP @ 1750 RPM	BELT SIZE	RATIO	“A”	“B”	“C”	“D”
SPEED SELECTOR	LOVEJOY							
8816		1/2 to 1	1422V	3.0:1	6.50	4.38	2.34	4.18
	21407	1/2 to 3/4	1422V	2.6:1	6.00	4.62	2.50	2.87
	21401	1	1422V	2.6:1	6.00	4.62	2.50	2.87
8827		1-1/2 to 3	1922V	3.0:1	7.75	5.25	2.81	4.62
	21901	1-1/2	1922V	3.0:1	8.25	6.75	3.62	3.00
	21902	2	1922V	3.0:1	8.25	6.75	3.62	3.00
	21903	3	1922V	3.0:1	8.25	6.75	3.62	3.00
8859		3 to 5	2322V	3.0:1	9.50	6.50	3.41	5.87
	3030E ¹	3	2322V	3.0:1	8.50	8.75	2.00	2.87
	22905*	5	2926V	3.0:1	10.00	8.25	4.31	6.62
8810		7-1/2 to 10	3226V	3.0:1	10.50	7.94	4.12	7.00
	23207*	7-1/2	3230HV	2.3:1	10.75	9.38	5.00	6.62
	23210*	10	3230HV	2.3:1	10.75	9.38	5.00	6.62
8822-2		20	3230HV	2.5:1	10.41	9.03	4.51	7.00
	23220	20	3230HV	2.3:1	10.75	9.38	5.00	6.62
8822-2.75		20	4430V	2.5:1	10.41	9.03	4.83	7.00
	032481H	20	4430V	2.2:1	10.00	9.81	5.06	6.62
8821		15 to 20	4430V	3.0:1	12.00	9.03	4.84	7.00
	24420	15 to 20	4430V	2.7:1	12.50	10.13	5.37	6.62
8813		7-1/2 to 10	4430V	3.0:1	13.00	9.44	5.03	7.94
	24407	7-1/2	4430V	2.7:1	12.50	10.13	5.37	6.62
	24410	10	4430V	2.7:1	12.50	10.13	5.37	6.62
8823		15 to 20	4430V	3.0:1	13.00	9.44	5.03	7.94
	24420	15 to 20	4430V	2.7:1	12.50	10.13	5.37	6.62
8833		25 to 30	4430V	3.0:1	13.00	9.44	5.03	7.94
	24430	25 to 30	4430V	2.7:1	12.50	10.13	5.37	6.62

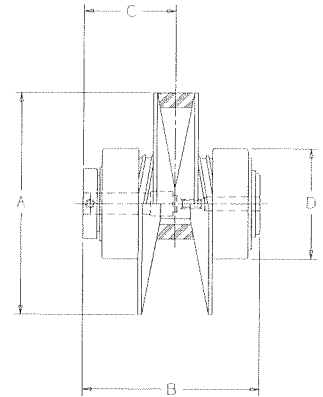

* Not an ideal interchange due to the difference in the belt width or angle. For best performance, you should consider replacing the entire drive.

¹ Requires sheave re-alignment.

SPEED SELECTOR

“Series 45”

Fixed Center Drives

DRIVER PULLEY MODEL NUMBER		DRIVEN PULLEY MODEL NUMBER		HP @ 1750 RPM (DRIVER)	BELT SIZE	DRIVEN SPEED RANGE (1750 RPM DRIVER)		“A” DRIVER O.D.	“B” DRIVEN O.D.	“C” OFFSET
SPEED SELECTOR	LOVEJOY	SPEED SELECTOR	LOVEJOY			MIN	MAX			
406		5116		1/2 to 1	1422V	506	3800	5.75	6.50	1.75
	M-14		1401	1/2 to 1	1422V	430	3300	6.00	7.00	1.59
	M-007		260	3/4	1422V	573	5342	6.00	6.00	0.00
407		5128		1-1/2 to 2	1922V	435	4250	7.125	8.00	2.00
	HM-3		31901	1 to 1-1/2	1922V	590	4850	8.25	8.25	2.21
	HM-3		31902	2	1922V	590	4850	8.25	8.25	2.21
	M-19		1902	1 to 2	1922V	403	4260	7.50	8.25	1.81
409		5151		3 to 5	2322V	444	3700	9.00	10.50	2.44
	M-23		2303	3	2322V	346	3700	9.50	11.00	1.40
	M-23		2305	5	2322V	346	3700	9.50	11.00	1.40
411		5112		7-1/2 to 10	3226V	495	3740	10.56	12.00	3.25
	HM-7*		32905	7-1/2	2926V	590	4000	10.00	10.00	1.89
	HM-30*		34407	10	4430V	640	3200	12.50	12.50	2.19
414		5122		15 to 20	3230HV	630	3300	10.62	12.00	2.90
	HM-30*		34410	15 to 20	4430V	640	3200	12.50	12.50	2.19
414		5133		25 to 30	3230HV	580	2775	10.62	13.00	3.34
	HM-30*		34420	25 to 30	4430V	640	3200	12.50	12.50	2.19

* Not an ideal interchange due to the difference in the belt width or angle. For best performance, you should consider replacing the entire drive.

These interchange suggestions are only to be used to replace a complete belt drive system. Do not attempt to replace just one part of the drive with a different manufacturer's pulley.

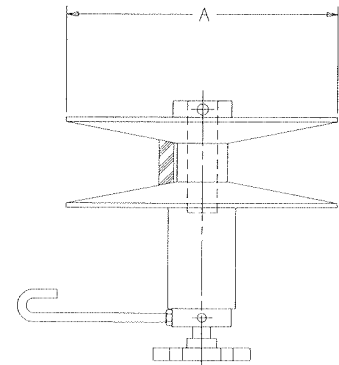

“M” Series

T.B. WOOD'S

“VPS” Series

Variable Speed Sheaves

MODEL NUMBER		BELT SIZE	P.D. RANGE		“A”	“B”
T.B. WOOD'S	LOVEJOY		MIN. P.D.	MAX. P.D.		
VPS-9-R		2530V	4.25	9.00	9.25	4.88
	LAS 25-10.25	2530V	5.00	9.95	10.25	5.38
VPS-10-R		2530V	5.25	10.00	10.25	4.88
	LAS 25-10.25	2530V	5.00	9.95	10.25	5.38
VPS-10-W		4430V	5.00	10.00	10.25	6.13
	LAS 44-10.75	4430V	4.84	10.35	10.75	7.38
VPS-129-W		4430V	4.30	12.90	13.00	7.00
	LAS 44-12.50	4430V	4.84	12.10	12.50	7.38

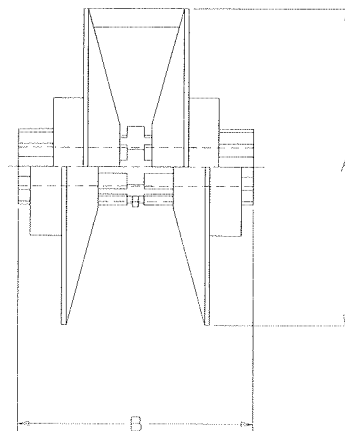

Variable Speed Pulley Interchange Guide



T.B. WOOD'S

"MCS" Series

2-Side Moveable

Spring Loaded Pulleys

MODEL NUMBER		HP @ 1750 RPM	BELT SIZE	RATIO	"A"	"B"	"C"	"D"
T.B. WOOD'S	LOVEJOY							
MCS-10W-HD	111979H-20	15	4430V	2.0:1	10.25	9.94	5.06	6.75
		15 to 20	4430V	2.1:1	10.75	10.12	5.34	6.63
MCS-12W-HD	24420	15 to 20	4430V	2.0:1	12.25	9.94	5.06	6.75
		15 to 20	4430V	2.7:1	12.50	10.12	5.38	6.63
MCS-11S	23230	25	3230HV	2.0:1	10.75	9.56	5.06	6.75
		25 to 30	3230HV	2.3:1	10.75	9.38	5.00	6.63
MCS-12S	112579H-30* 021881H-30*	25	3230HV	2.0:1	12.25	9.56	5.12	6.75
		25 to 30	3230HV	2.0:1	12.50	9.33	4.97	6.63
		25 to 30	3230HV	2.0:1	12.25	8.94	4.75	6.63
MCS-13S	05188H*	30	3230HV	2.0:1	13.00	9.56	5.12	6.75
		30	3230HV	2.0:1	13.00	9.56	5.12	6.63

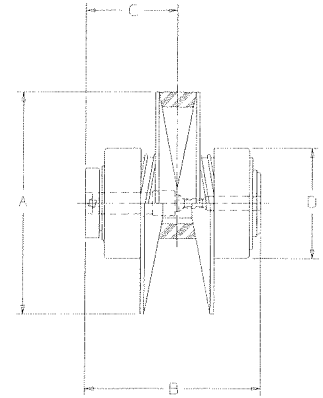

* These models are designed for **driven** applications only. For **driver** applications, please consult the factory.

T.B. WOOD'S

"PRO" Series

2-Side Moveable

Spring Loaded Pulleys

MODEL NUMBER		HP @ 1750 RPM	BELT SIZE	RATIO	"A"	"B"	"C"	"D"
T.B. WOOD'S	LOVEJOY							
160N		1 to 2	1922V	3.0:1	6.50	5.50	2.75	4.00
	21901	1-1/2	1922V	3.0:1	8.25	6.75	3.63	3.00
	21902	2	1922V	3.0:1	8.25	6.75	3.63	3.00
200N	21903	3 to 5	1922V	3.0:1	8.10	6.13	3.07	5.20
		3	1922V	3.0:1	8.25	6.75	3.63	3.00
240T	22907 22908	7-1/2 to 10	2926V	3.0:1	9.80	8.44	4.21	5.25
		7-1/2	2926V	3.0:1	10.00	8.25	4.31	6.63
		7-1/2 HD	2926V	3.0:1	10.00	8.25	4.31	6.63
250S	23220	15	3230HV	2.4:1	10.40	10.00	5.00	6.50
		15 to 20	3230HV	2.3:1	10.75	9.38	5.00	6.63
250W	24420 111979H-20	20	4430V	2.0:1	10.40	10.00	5.00	6.50
		15 to 20	4430V	2.7:1	12.50	10.12	5.38	6.63
		15 to 20	4430V	2.1:1	10.75	10.12	5.34	6.63
300W	24420	20	4430V	2.9:1	12.30	10.00	5.00	6.50
		15 to 20	4430V	2.7:1	12.50	10.12	5.38	6.63
320W	24430 072790H	30	4430V	3.0:1	13.00	10.50	5.25	6.50
		25 to 30	4430V	2.7:1	12.50	10.12	5.38	6.63
		25 to 30	4430V	2.8:1	13.00	10.13	5.38	6.63

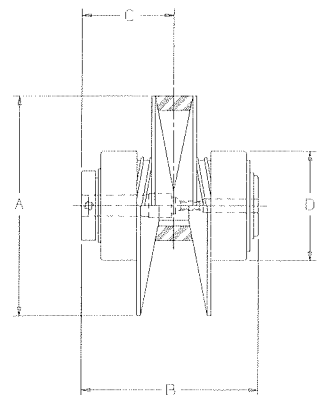

T.B. WOOD'S

"All-Pro" Series

2-Side Moveable

Spring Loaded Pulleys

MODEL NUMBER		HP @ 1750 RPM	BELT SIZE	RATIO	"A"	"B"	"C"	"D"
T.B. WOOD'S	LOVEJOY							
AP160M		1 to 1-1/2	1922V	3.0:1	6.50	5.50	2.75	4.00
	21901	1	1922V	3.0:1	8.25	6.75	3.63	3.00
	21902	2	1922V	3.0:1	8.25	6.75	3.63	3.00
AP200N		2 to 5	1922V	3.0:1	8.10	6.13	3.07	5.20
	21903	3	1922V	3.0:1	8.25	6.75	3.63	3.00
AP260T		5 to 10	2926V	3.0:1	10.50	7.48	3.74	5.40
	22905	5	2926V	3.0:1	10.00	8.25	4.31	6.63
	22907	7-1/2	2926V	3.0:1	10.00	8.25	4.31	6.63
	22908	8	2926V	3.0:1	10.00	8.25	4.31	6.63
AP260U*		5 to 10	3226V	2.4:1	10.50	7.48	3.74	5.40
	23207*		3230HV	2.3:1	10.75	9.38	5.00	6.63
	23210*		3230HV	2.3:1	10.75	9.38	5.00	6.63
AP255W		7-1/2 to 15	4430V	2.5:1	10.40	9.60	4.80	6.67
	24407	7-1/2	4430V	2.7:1	12.50	10.13	5.38	6.63
	24410	10	4430V	2.7:1	12.50	10.13	5.38	6.63
	24420	15 to 20	4430V	2.7:1	12.50	10.13	5.38	6.63
AP255S		10 to 20	3230HV	2.5:1	10.40	9.60	4.80	6.67
	23210	10	3230HV	2.3:1	10.75	9.38	5.00	6.63
	23210	20	3230HV	2.3:1	10.75	9.38	5.00	6.63
AP321W		7-1/2 to 10	4430V	3.0:1	13.00	9.60	4.80	6.67
	24407	7-1/2	4430V	2.7:1	12.50	10.13	5.38	6.63
	24410	10	4430V	2.7:1	12.50	10.13	5.38	6.63
AP322W		10 to 20	4430V	3.0:1	13.00	9.60	4.80	6.67
	24410	10	4430V	2.7:1	12.50	10.13	5.38	6.63
	24420	20	4430V	2.7:1	12.50	10.13	5.38	6.63
AP323W		15 to 30	4430V	3.0:1	13.00	9.60	4.80	6.67
	24420	25 to 30	4430V	2.7:1	12.50	10.13	5.38	6.63
	24430	25 to 30	4430V	2.7:1	12.50	10.13	5.38	6.63

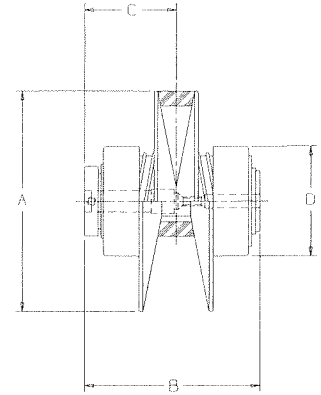

* Not an ideal interchange due to the difference in the belt width. For best performance, you should consider replacing the entire drive.

T.B. WOOD'S

"Roto-Cone" Series

2-Side Moveable

Spring Loaded Pulleys

MODEL NUMBER		HP @ 1750 RPM	BELT SIZE	RATIO	"A"	"B"	"C"	"D"
T.B. WOOD'S	LOVEJOY							
RC55		1/2	1422V	3.0:1	5.50	5.125	1.00	2.125
	245	1/2	1422V	3.0:1	6.00	4.86	1.31	2.25
RC60*		3/4	1922V	3.0:1	6.00	6.06	.94	2.125
	260*	3/4	1422V	3.0:1	6.00	4.86	1.31	2.25
RC75		1 to 1-1/2	1922V	3.0:1	7.50	7.50	1.25	2.50
	301E	1 to 1-1/2	1922V	3.0:1	7.50	7.13	1.56	2.50
RC80		3	2322V	3.0:1	8.00	8.50	1.44	3.00
	3030E	3	2322V	3.0:1	8.50	8.75	2.00	2.87
RC105		3	2926V	4.0:1	10.62	8.5	1.81	3.00
	403E	3	2926V	3.8:1	11.00	8.75	1.81	2.87
RC100		5	2926V	3.0:1	10.00	10.81	2.06	3.87
	3050E	5	2926V	3.0:1	10.00	10.31	2.13	3.19
RC1315		15	4430V	3.0:1	13.00	12.87	2.25	5.00
	3150B	15	4430V	3.0:1	13.00	13.44	2.50	4.00

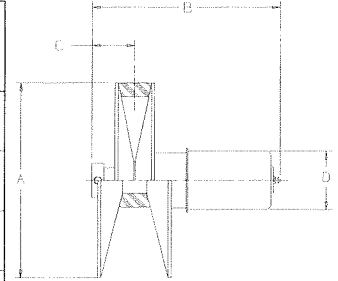

If any of the above Wood's model numbers contain a "W" suffix, it is a manually adjustable pulley. These are not directly interchangeable with Lovejoy. The entire drive will need to be replaced. Call Lovejoy Engineering for assistance.

* Not an ideal interchange due to the difference in the belt width. For best performance, you should consider replacing the entire drive.

Lovejoy Pulley Refurbishing Service

Variable Speed Pulleys are often exposed to harsh environments and tough operating conditions which can reduce the pulley's service life. Fortunately, Lovejoy's Variable Speed Pulley Refurbishing Service offers the opportunity to have your Lovejoy pulley inspected and evaluated for possible refurbishing and repair. Some pulleys may only need individual parts replaced in order to be brought back into service. Therefore, refurbishing is often less costly than replacement.

Additionally, pulley inspection can often spot potential problems in the drive setup and operation, such as worn or undersized shafts, belt misalignment and a variety of other problems. While Lovejoy can truly be your variable speed drive partner, it is important to remember that not all pulley repairs will be cost effective. Contact Lovejoy Customer Service for complete information on the Lovejoy Pulley Refurbishing Service.

Lovejoy's Variable Speed Pulley-Belt Drive Trouble-Shooting Guide

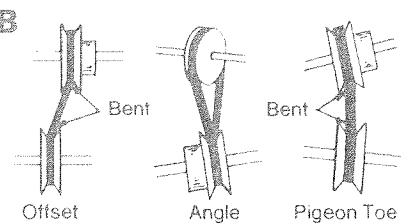
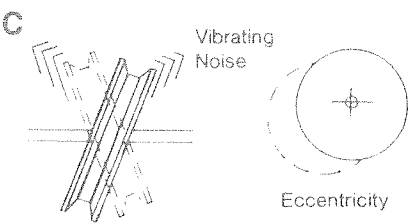
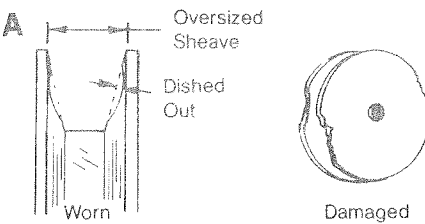
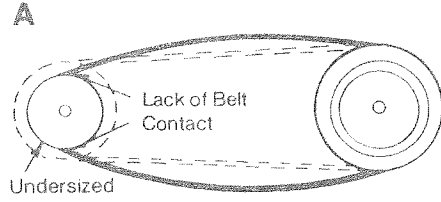
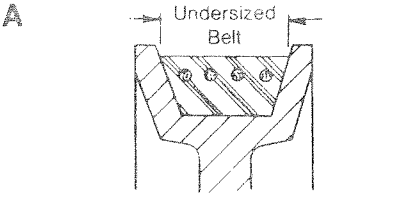
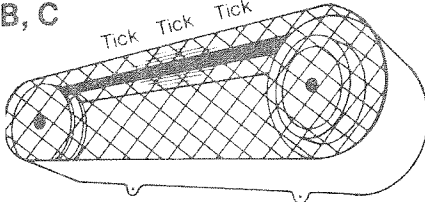
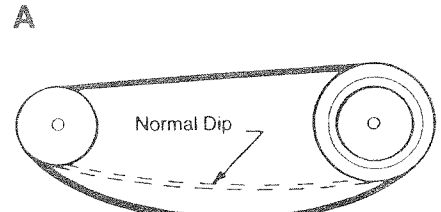
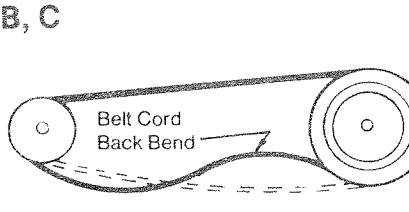
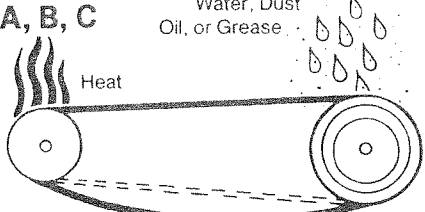
 <p>MISALIGNED SHEAVES</p>	 <p>SHEAVE WOBBLE</p>	 <p>SHEAVE PROBLEMS</p>
 <p>IMPROPER SHEAVE SIZE</p>	 <p>BELT BOTTOMING</p>	 <p>MECHANICAL INTERFERENCE</p>
 <p>OVERLOADED DRIVE</p>	 <p>EXCESSIVE BELT TENSION</p>	 <p>BELT HOP AND SLIP</p>

PROBLEM	PROBABLE CAUSE	SUGGESTED CORRECTION
<p>A</p> <p>BELT SLIPPAGE</p> <ul style="list-style-type: none"> • Rule of thumb very audible belt squeal = 5% or more belt slippage 	<ol style="list-style-type: none"> 1. Overloaded drive 2. Worn sheaves 3. Excessive dust, oil, or grease 4. Lack of flange support (weak VSP spring tension or broken spring) 5. Improper companion sheave size 6. Undersized P.D. (Belt Riding on bottom of sheave) 	<ul style="list-style-type: none"> • Check motor ampere load to max. speed range of pulley drive to insure proper size drive package selected. • Replace worn sheaves • Provide better shielding • Replace weak or broken spring; Consult factory; consult catalog for pulley rating • Consult catalog specifications and factory • 1/32" min. belt clearance when belt at pulley's specified minimum pitch diameter
<p>B</p> <p>RAPID BELT WEAR</p> <ul style="list-style-type: none"> • Heavy rubber dust deposit • Belt side "wear" pattern irregular • Heat build-up beyond 160°F max. limit 	<ol style="list-style-type: none"> 1. Misaligned sheaves 2. Loose motorbase supports 3. Damaged or worn sheaves 4. Excessive temperatures 5. Mechanical interference 6. Overloaded drive 7. Broken belt cords (excessive spring tension) 8. Dirt and grit entering drive 	<ul style="list-style-type: none"> • Realign sheaves — remove "bends" • Replace undersize screws or broken base • Replace sheaves • Ventilate belt guard — determine cause • Remove interference — move pulley over • Increase pitch diameter • Reduce pulley HP rating — reduce spring tension • Air ventilate belt guard
<p>C</p> <p>VIBRATION</p> <ul style="list-style-type: none"> • Pulley sheave lacks dynamic smoothness common to belt drive arrangement 	<ol style="list-style-type: none"> 1. Sheave wobble 2. Pulleys or sheaves out of balance 3. Mechanical interference 4. Pulsating loads belt hop and skip 5. Undersized motorshaft 6. Bent shaft 7. Worn — Undersize motorbase — Improper installation 8. Excessive pulley spring tension 	<ul style="list-style-type: none"> • Replaced distorted sheave rim; replace worn "QD" bushing • Determine cause, return to factory for correction • Enlarge belt guard, and avoid pulley housing contact • Belt's side surfaces glazed - replace; remove oil from pulley's flange surfaces • Correct or resize shaft diameter per NEMA specifications • Replace shaft • Replace, consult catalog for HP rating <ul style="list-style-type: none"> • Install lighter HP rated pulley consult factory.